

PARTS
CATALOG

imageCLASS
LBP352dn
LBP351dn



Canon

July 9, 2020
Rev. 3

Index

SNL	Product Code No. /Serial No.
A1	ASSEMBLY LOCATION DIAGRAM
A2	OPTION PARTS CATALOG LIST
001B	ACCESSORIES (120V)
001C	ACCESSORIES (230V)
100B	EXTERNAL COVERS, PANELS, ETC. (LBP351dn, LBP352dn)
100C	EXTERNAL COVERS, PANELS, ETC. (LBP351x, LBP352x)
101	INTERNAL COMPONENTS 1
102	INTERNAL COMPONENTS 2
103B	INTERNAL COMPONENTS 3 (120V)
103C	INTERNAL COMPONENTS 3 (230V)
104B	INTERNAL COMPONENTS 4
110A	POWER SUPPLY ASS'Y (100V, 120V)
110B	POWER SUPPLY ASS'Y (230V)
330	MULTI-PURPOSE PICK-UP ASS'Y
900C	CONTROLLER PCB ASSEMBLY (LBP351dn, LBP351x)
900D	CONTROLLER PCB ASSEMBLY (LBP352dn, LBP352x)
S10	DUPLEXING UNIT
ZZA	MECHANICAL STANDARD PARTS (HOW TO USE)
ZZB	MECHANICAL STANDARD PARTS (SCREWS)
ZZC	MECHANICAL STANDARD PARTS (BOLTS)
ZZD	MECHANICAL STANDARD PARTS (NUTS)
ZZE	MECHANICAL STANDARD PARTS (RETAINING RINGS)

Figure SNL Product Code No./Serial No.

	Product Code No.	Model Name	Remarks	Serial No.
1	F16-8231-000	imageCLASS LBP351dn	120V	NEQA, NLLA
2	F16-9431-000	imageCLASS LBP352dn	120V	NEXA, NLQA
3	F16-8291-000	LBP351x	230V	NERA, NLMA
4	F16-9491-000	LBP352x	230V	NEYA, NLRA

	中オーダー	製品名	備考	シリアル No.
1	F16-8231-000	imageCLASS LBP351dn	120V	NEQA, NLLA
2	F16-9431-000	imageCLASS LBP352dn	120V	NEXA, NLQA
3	F16-8291-000	LBP351x	230V	NERA, NLMA
4	F16-9491-000	LBP352x	230V	NEYA, NLRA

FIGURE & KEY NO.	PART NUMBER	RANK	QTY	DESCRIPTION	SERIAL NUMBER /REMARKS
SNL	NPN		RF	Product Code No./Serial No.	
1	F16-8231-000		1	imageCLASS LBP351dn	NEQA, NLLA 120V
2	F16-9431-000		1	imageCLASS LBP352dn	NEXA, NLQA 120V
3	F16-8291-000		1	LBP351x	NERA, NLMA 230V
4	F16-9491-000		1	LBP352x	NEYA, NLRA 230V

Figure A1 ASSEMBLY LOCATION DIAGRAM

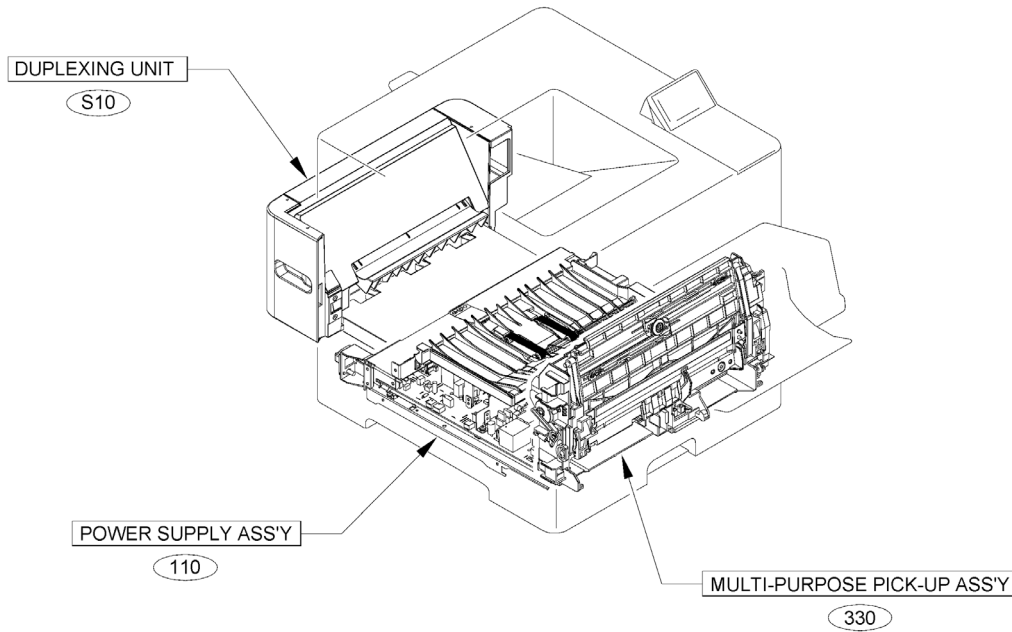

Figure A2 OPTION PARTS CATALOG LIST

This is the table of the machine's options whose parts catalog is issued.
 本機のオプションで、パーツカタログが発行されている機種の一覧である。

No.	Model Name(English)	Model Name(Japanese)
1	Paper Feeder PF-B1	ペーパーフィーダー B 1
2	Paper Deck Unit PD-G1	ペーパーデッキユニット P D - G 1
3	A5 Cassette C-A1	A 5 カセット C - A 1
4	Custom Media Cassette CM-A1	カスタムメディアカセット C M - A 1
5	Envelope Feeder EF-A1	封筒フィーダー E F - A 1
6	(JAPAN ONLY)	環境ヒーター E H - B 1
7	PCL FONT SET-C1	(日本仕向けなし)

Figure 001B ACCESSORIES (120V)

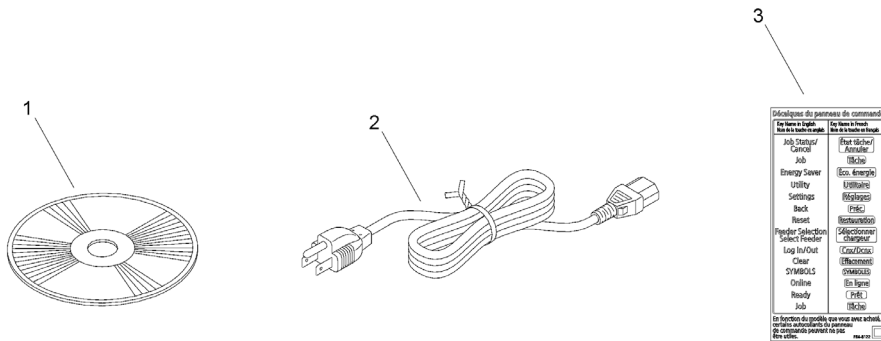

FIGURE & KEY NO.	PART NUMBER	RANK	QTY	DESCRIPTION	SERIAL NUMBER /REMARKS
001B	NPN		RF	ACCESSORIES	120V
1	FK4-3515-000		1	DVD-ROM, USER SOFTWARE	
2	FK2-9583-000		1	CORD, POWER	
3	FE4-8122-000		1	LABEL, PANEL	

Figure 001C ACCESSORIES (230V)

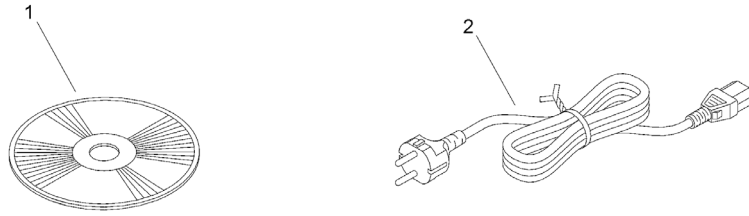

FIGURE & KEY NO.	PART NUMBER	RANK	QTY	DESCRIPTION	SERIAL NUMBER /REMARKS
001C	NPN		RF	ACCESSORIES	230V
1	FK4-3514-000		1	DVD-ROM, USER SOFTWARE	
2	FK4-3388-000		1	CORD, POWER	

Figure 100B EXTERNAL COVERS, PANELS, ETC. (LBP351dn, LBP352dn)

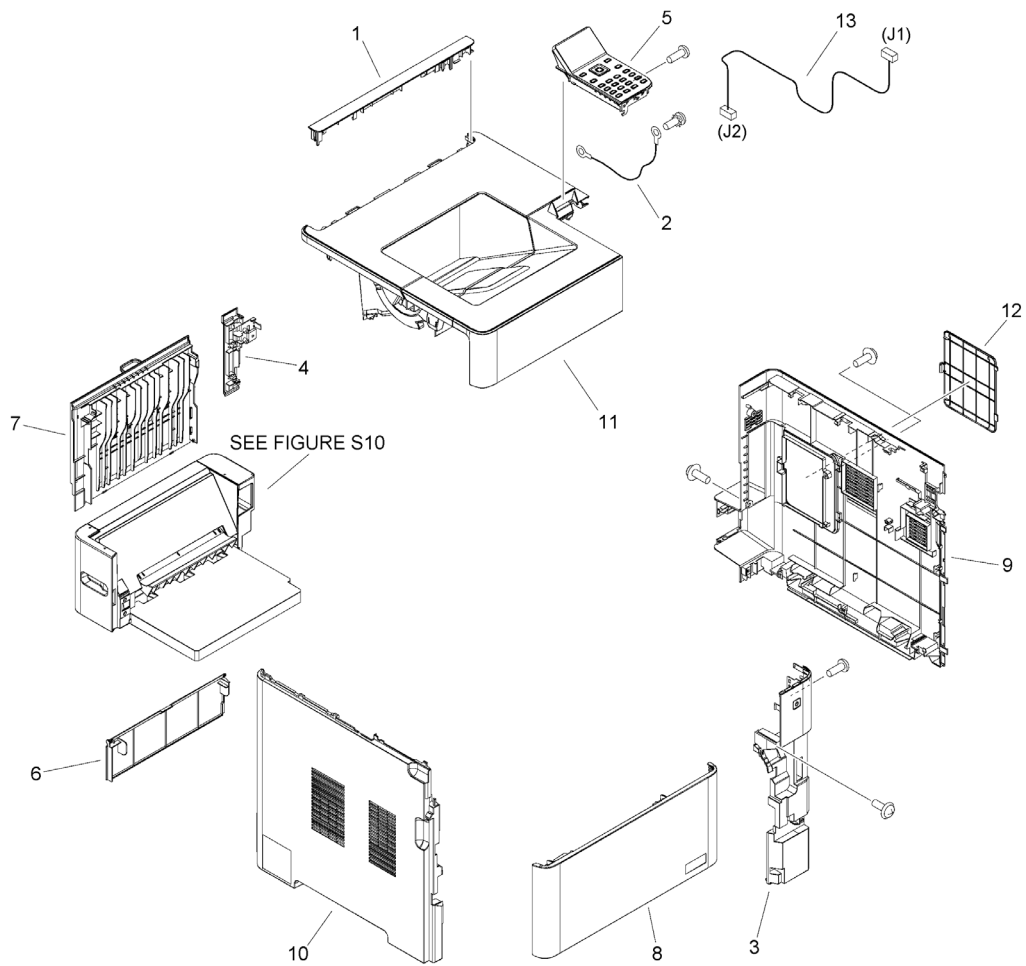

FIGURE & KEY NO.	PART NUMBER	RANK	QTY	DESCRIPTION	SERIAL NUMBER /REMARKS
100B	NPN		RF	EXTERNAL COVERS, PANELS, ETC.	LBP351dn, LBP352dn
1	FE4-7997-000		1	COVER, TOP REAR	
2	FM1-U850-000		1	CABLE, PANEL GND	
3	FM1-J622-000		1	COVER, RIGHT FRONT	
4	FE4-8006-000		1	COVER, RIGHT REAR	
5	FM1-J624-000		1	OPERATION PANEL ASS'Y	
6	FE4-8007-000		1	COVER, LEGAL	
7	FM1-J610-000		1	FACE-UP TRAY ASS'Y	
8	FM1-J619-000		1	FRONT COVER ASS'Y	
9	FM1-J617-000		1	RIGHT COVER ASS'Y	
10	FM1-J618-000		1	LEFT COVER ASS'Y	
11	FM1-J613-000		1	TOP COVER ASS'Y	
12	FE4-7999-000		1	COVER, RIGHT WINDOW	
13	FM1-U814-000		1	CABLE, PANEL	

Figure 100C EXTERNAL COVERS, PANELS, ETC. (LBP351x, LBP352x)

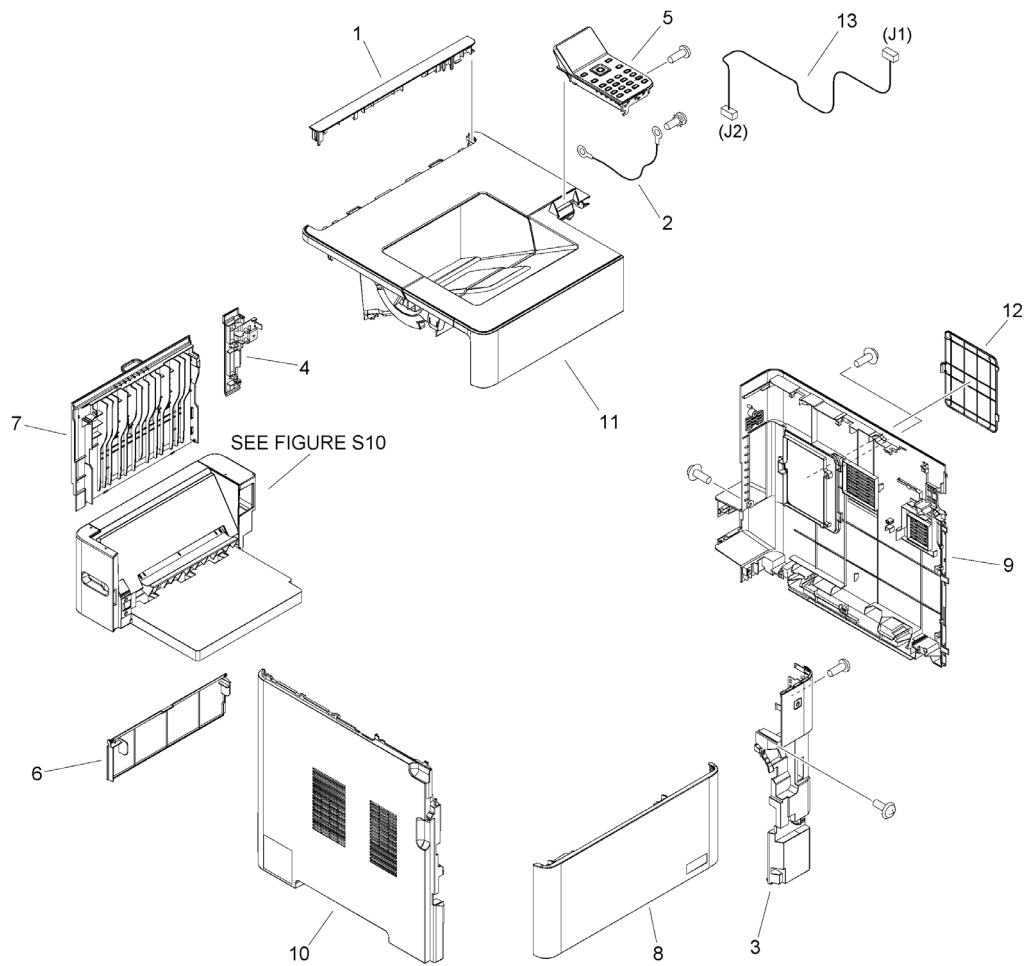

FIGURE & KEY NO.	PART NUMBER	RANK	QTY	DESCRIPTION	SERIAL NUMBER /REMARKS
100C	NPN		RF	EXTERNAL COVERS, PANELS, ETC.	LBP351x, LBP352x
1	FE4-7997-000		1	COVER, TOP REAR	
2	FM1-U850-000		1	CABLE, PANEL GND	
3	FM1-J622-000		1	COVER, RIGHT FRONT	
4	FE4-8006-000		1	COVER, RIGHT REAR	
5	FM1-K563-000		1	OPERATION PANEL ASS'Y	
6	FE4-8007-000		1	COVER, LEGAL	
7	FM1-J610-000		1	FACE-UP TRAY ASS'Y	
8	FM1-J619-000		1	FRONT COVER ASS'Y	
9	FM1-J617-000		1	RIGHT COVER ASS'Y	
10	FM1-J618-000		1	LEFT COVER ASS'Y	
11	FM1-J613-000		1	TOP COVER ASS'Y	
12	FE4-7999-000		1	COVER, RIGHT WINDOW	
13	FM1-U814-000		1	CABLE, PANEL	

Figure 101 INTERNAL COMPONENTS 1

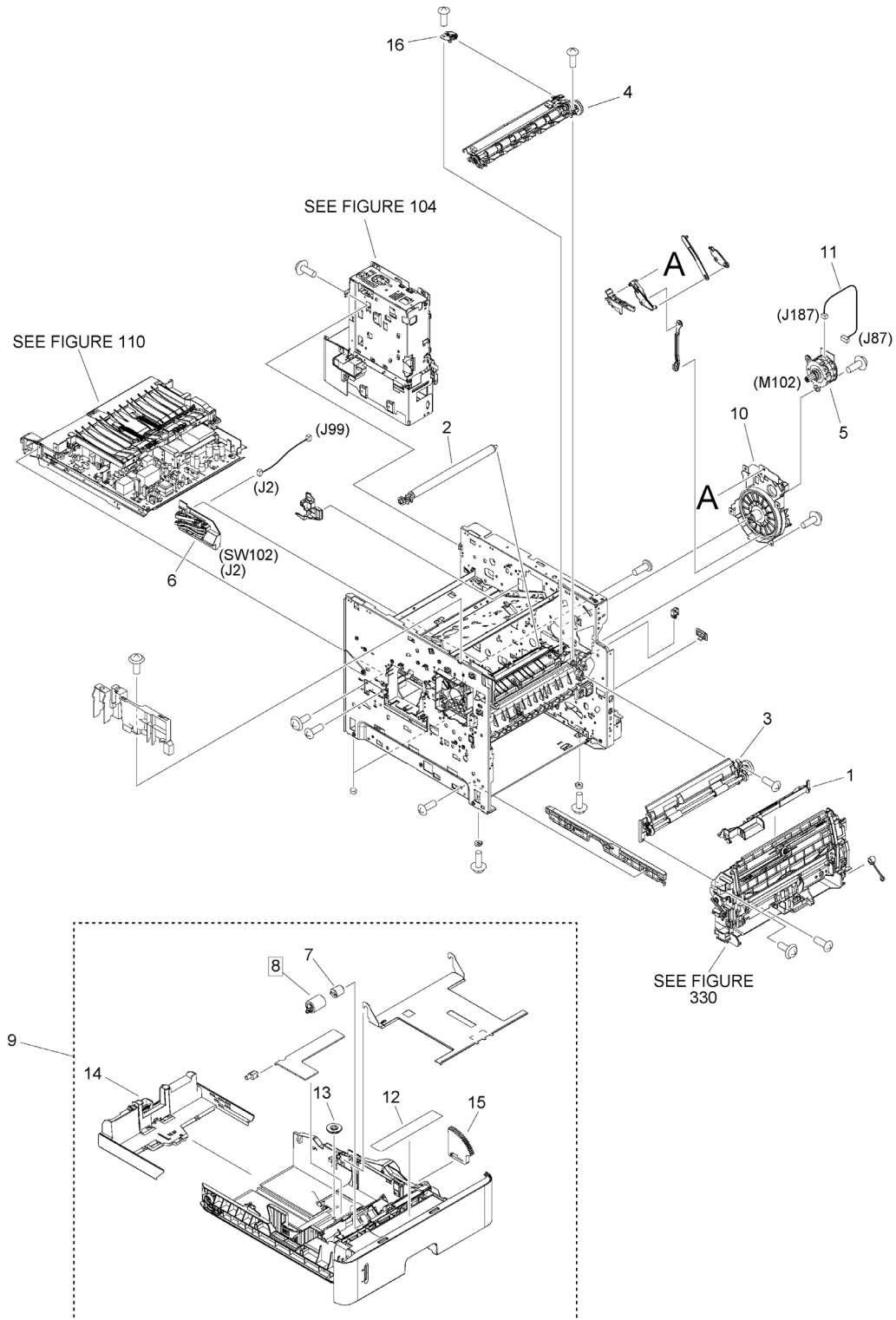

FIGURE & KEY NO.	PART NUMBER	RANK	QTY	DESCRIPTION	SERIAL NUMBER /REMARKS
101	NPN		RF	INTERNAL COMPONENTS 1	
1	FL0-6303-000		1	COVER, ENV	
2	RM1-8491-000		1	TRANSFER ROLLER KIT	
3	RM1-8411-010		1	PAPER FEED ROLLER ASS'Y	
4	FM1-L432-000		1	REGISTRATION ASS'Y	
5	RM1-8358-000		1	DRUM MOTOR ASS'Y	M102
6	RM1-4525-000		1	SIZE DETECT ASS'Y	SW102
7	RC2-5771-000		1	TORQUE LIMITER	
8	RM2-5642-000		1	PAPER FEED ROLLER ASS'Y	[DP]
9	FM1-J607-000		1	CASSETTE ASS'Y	
10	RM2-6920-000		1	DRUM DRIVE ASS'Y	
11	FM1-K774-000		1	CABLE, DRUM MOTOR	
12	FE4-8039-000		1	LABEL, PAPER SET	
13	RC1-0331-000		1	GEAR, 20T	
14	RM1-1089-030		1	CASSETTE REAR ASS'Y	
15	RU5-0025-000		1	GEAR, 88T	
16	RM1-5461-000		1	GROUNDING PLATE ASS'Y	

Figure 102 INTERNAL COMPONENTS 2

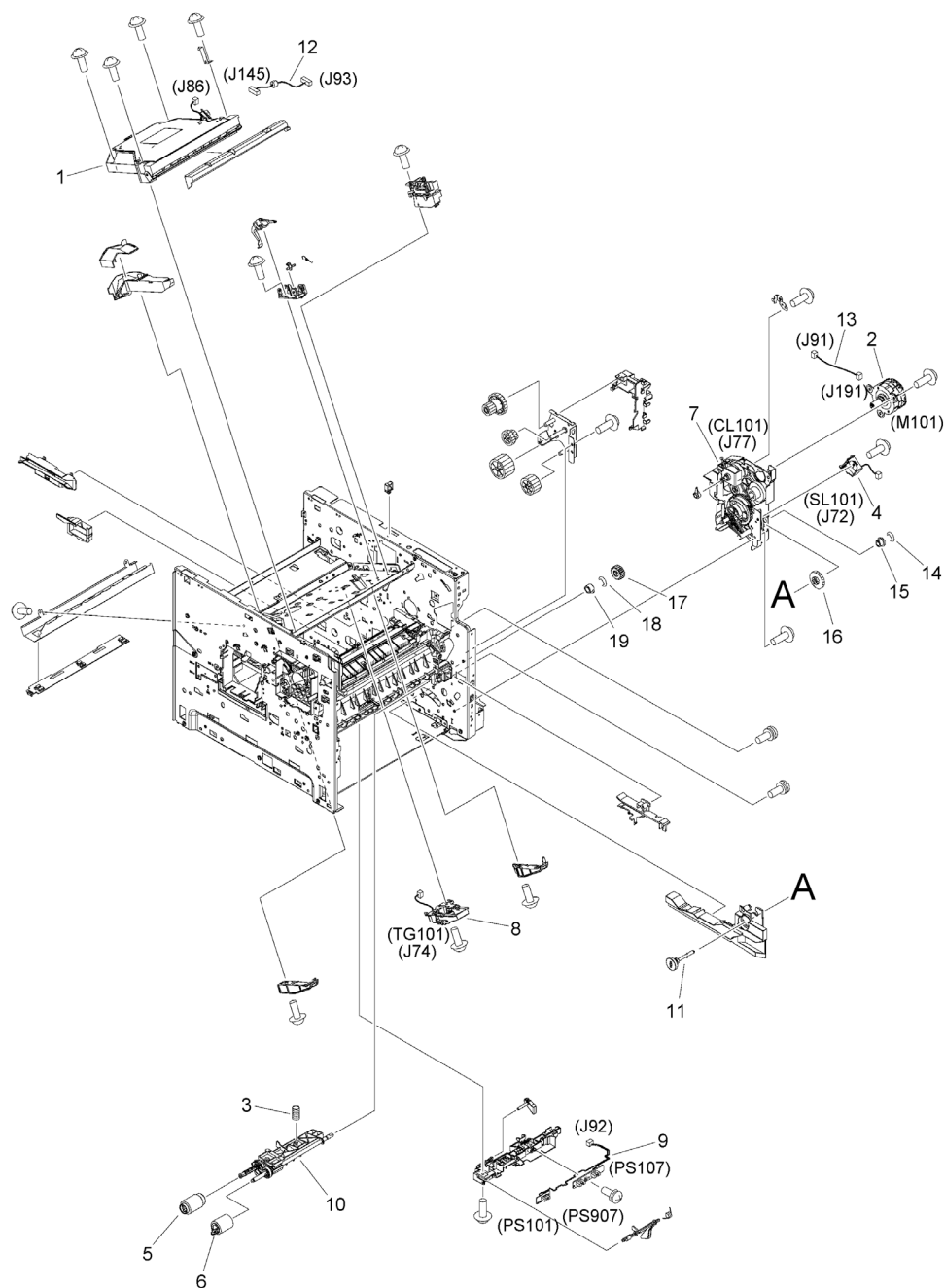

FIGURE & KEY NO.	PART NUMBER	RANK	QTY	DESCRIPTION	SERIAL NUMBER /REMARKS
102	NPN		RF	INTERNAL COMPONENTS 2	
1	RM1-8406-000		1	LASER SCANNER ASS'Y	
2	RM1-8285-000		1	PAPER FEED MOTOR ASS'Y	M101
3	RC1-0213-000		1	SPRING, COMPRESSION	
4	RL2-1409-000		1	SOLENOID	SL101
5	RM2-6046-000		1	PAPER PICK-UP ROLLER ASS'Y	
6	RM2-5642-000		1	PAPER FEED ROLLER ASS'Y	
7	RM1-8415-000		1	PAPER PICK-UP DRIVE ASS'Y	CL101
8	RM1-4539-000		1	TAG HOLDER ASS'Y	TG101
9	RM2-7687-000		1	FEEDER SENSOR CABLE ASS'Y	PS101, PS107, PS907
10	RM1-8424-000		1	PAPER FEED SHAFT ASS'Y	
11	RL1-3020-000		1	SHAFT, RETARD DRIVE	
12	RM1-8340-000		1	CABLE, LASER	
13	RM1-8311-000		1	CABLE, FEED MOTOR	
14	RC4-7642-000		1	RING, E	
15	RC1-0214-000		1	BUSHING	
16	RU5-0040-000		1	GEAR, 23T	
17	RU5-0088-000		1	GEAR, 18T	
18	RC4-7643-000		1	RING, E	
19	RC3-1403-000		1	BUSHING	

Figure 103B INTERNAL COMPONENTS 3 (120V)

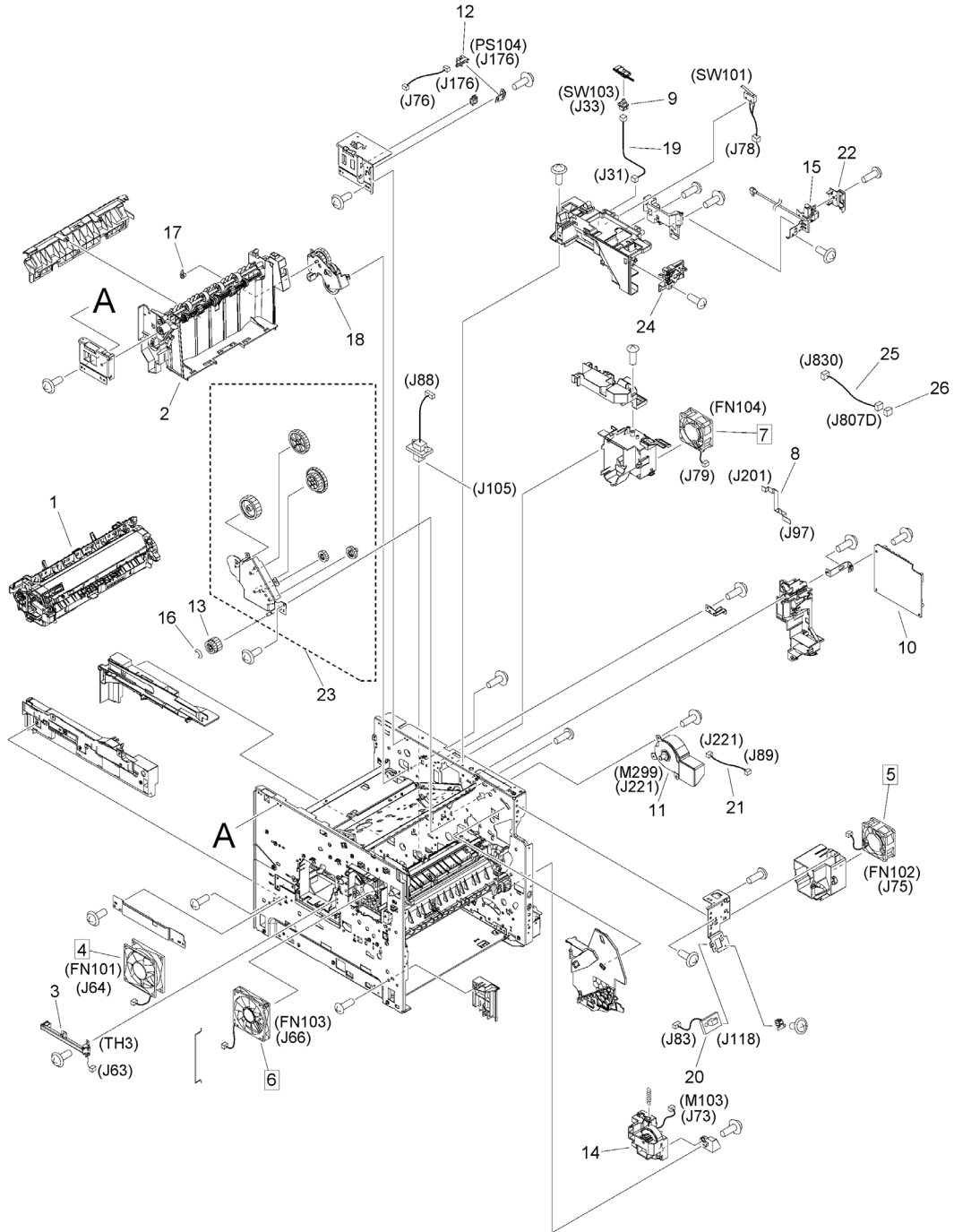

FIGURE & KEY NO.	PART NUMBER	RANK	QTY	DESCRIPTION	SERIAL NUMBER /REMARKS
103B	NPN		RF	INTERNAL COMPONENTS 3	120V
1	RM2-6308-000		1	FIXING ASS'Y	
2	FM1-J621-000		1	PAPER DELIVERY ASS'Y	
3	RM1-8438-000		1	TEMPERATURE SENSOR ASS'Y	TH3
4	RK2-1988-000		1	FAN	FN101 [DP]
5	RK2-1989-000		1	FAN	FN102 [DP]
6	RK2-3244-000		1	FAN	FN103 [DP]
7	RK2-1992-000		1	FAN	FN104 [DP]
8	FK4-3450-000		1	CABLE, FLEXIBLE FLAT	
9	WC2-5637-000		1	SWITCH, PUSH	SW103
10	FM1-U832-000		1	DC CONTROLLER PCB ASS'Y	
11	RM1-8928-000		1	FIXING MOTOR ASS'Y	M299
12	WG8-5849-000		1	IC, PHOTO INTERRUPTER	PS104
13	RU7-0295-000		1	GEAR, 23T/19T	
14	RM2-6335-010		1	LIFTER DRIVE ASS'Y	M103
15	FM1-K574-000		1	USB CABLE ASS'Y	
16	RC4-7642-000		1	RING, E	
17	RC1-0136-000		1	BUSHING, PAPER DELIVERY	
18	RM2-6318-000		1	PAPER DELIVERY DRIVE ASS'Y	
19	FM1-U851-000		1	CABLE, DOOR SWITCH	
20	RM1-5085-000		1	CABLE, ENVELOPE FEEDER	
21	RM1-5088-000		1	CABLE, FIXING MOTOR	
22	FE4-8096-000		1	COVER, USB	
23	RM2-6321-000		1	FIXING DRIVE ASS'Y	
24	FM1-J623-000		1	SWITCH PCB ASS'Y	
25	FM1-U846-000		1	CABLE, MAIN SWITCH	
26	VS1-7207-003		1	CONNECTOR, SNAP TIGHT, BK	

Figure 103C INTERNAL COMPONENTS 3 (230V)

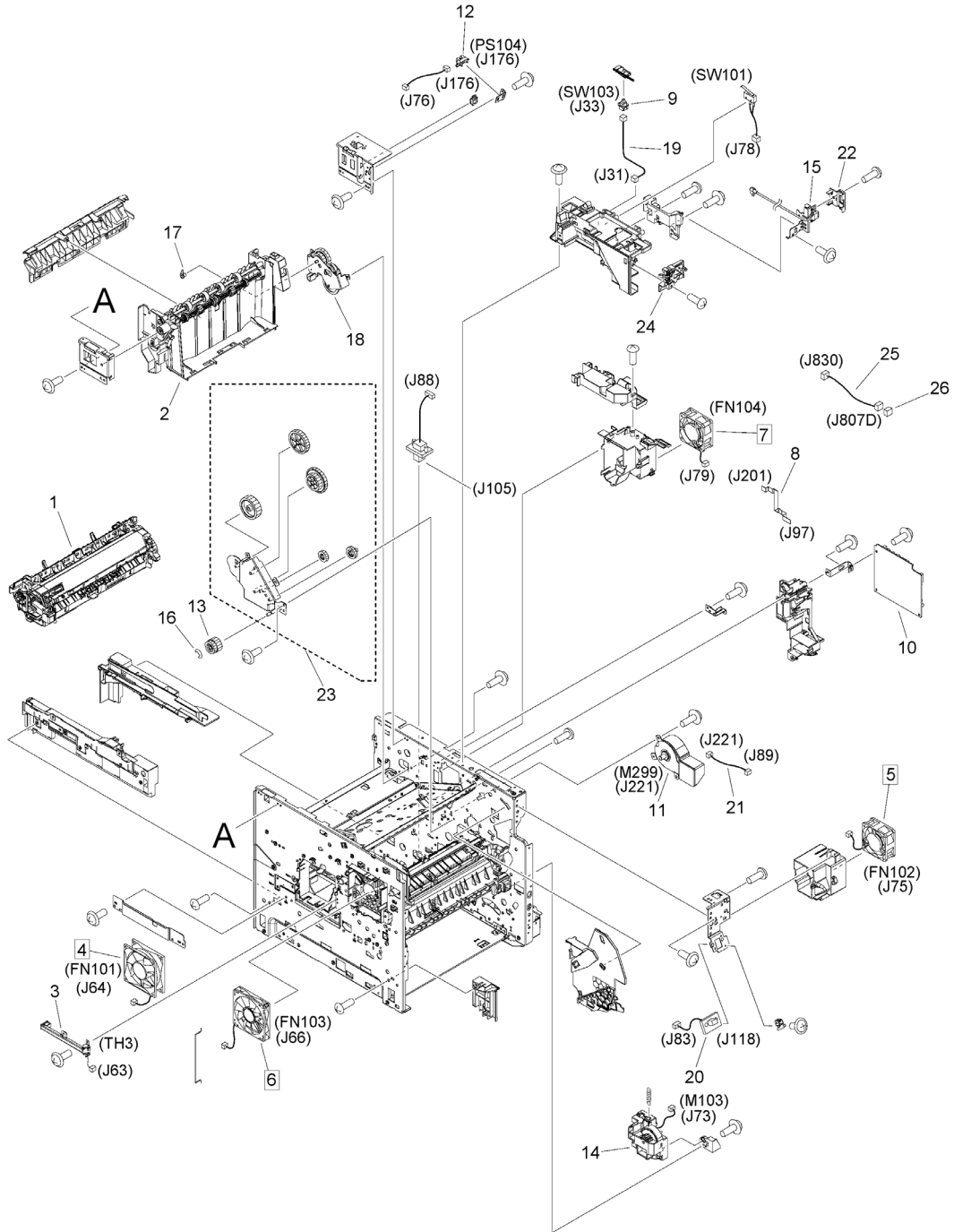

FIGURE & KEY NO.	PART NUMBER	RANK	QTY	DESCRIPTION	SERIAL NUMBER /REMARKS
103C	NPN		RF	INTERNAL COMPONENTS 3	230V
1	RM2-6342-000		1	FIXING ASS'Y	
2	FM1-J621-000		1	PAPER DELIVERY ASS'Y	
3	RM1-8438-000		1	TEMPERATURE SENSOR ASS'Y	TH3
4	RK2-1988-000		1	FAN	FN101 [DP]
5	RK2-1989-000		1	FAN	FN102 [DP]
6	RK2-3244-000		1	FAN	FN103 [DP]
7	RK2-1992-000		1	FAN	FN104 [DP]
8	FK4-3450-000		1	CABLE, FLEXIBLE FLAT	
9	WC2-5637-000		1	SWITCH, PUSH	SW103
10	FM1-U832-000		1	DC CONTROLLER PCB ASS'Y	
11	RM1-8928-000		1	FIXING MOTOR ASS'Y	M299
12	WG8-5849-000		1	IC, PHOTO INTERRUPTER	PS104
13	RU7-0295-000		1	GEAR, 23T/19T	
14	RM2-6335-010		1	LIFTER DRIVE ASS'Y	M103
15	FM1-K574-000		1	USB CABLE ASS'Y	
16	RC4-7642-000		1	RING, E	
17	RC1-0136-000		1	BUSHING, PAPER DELIVERY	
18	RM2-6318-000		1	PAPER DELIVERY DRIVE ASS'Y	
19	FM1-U851-000		1	CABLE, DOOR SWITCH	
20	RM1-5085-000		1	CABLE, ENVELOPE FEEDER	
21	RM1-5088-000		1	CABLE, FIXING MOTOR	
22	FE4-8096-000		1	COVER, USB	
23	RM2-6321-000		1	FIXING DRIVE ASS'Y	
24	FM1-J623-000		1	SWITCH PCB ASS'Y	
25	FM1-U846-000		1	CABLE, MAIN SWITCH	
26	VS1-7207-003		1	CONNECTOR, SNAP TIGHT, BK	

Figure 104B INTERNAL COMPONENTS 4

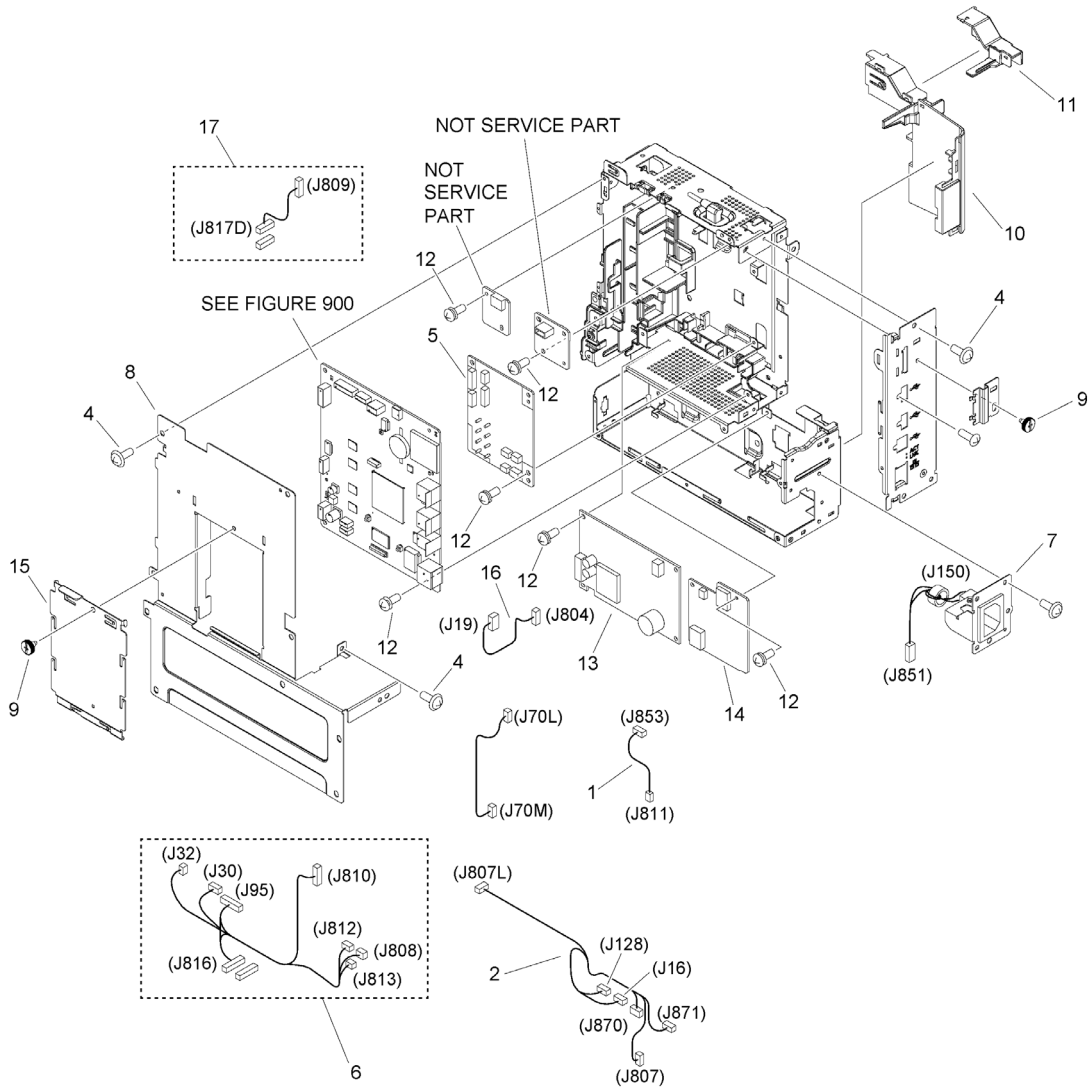

FIGURE & KEY NO.	PART NUMBER	RANK	QTY	DESCRIPTION	SERIAL NUMBER /REMARKS
104B	NPN		RF	INTERNAL COMPONENTS 4	
1	FM1-U843-000		1	CABLE, AC RELAY-SLEEP	
2	FM1-U852-000		1	CABLE, TRINITY	
4	XA9-1469-000		11	SCREW, TP,M3X6	
5	FM1-U816-000		1	SLEEP IF PCB ASS'Y	
6	FM1-U844-000		1	CABLE, SPIDER	
7	FM1-K573-000		1	CABLE, INLET	
8	FE4-8016-000		1	COVER, ELE. C. BOX	
9	FC5-7039-000		2	SCREW, FIXED	
10	FE4-8018-000		1	COVER, INLET INSIDE	
11	FE4-8019-000		1	LID, PS CABLE	
12	XA9-1420-000		12	SCREW, W/WASHER, M3X8	
13	FK3-1997-000		1	ALL NIGHT POWER SUPPLY PCB	
14	FM1-U817-000		1	AC RELAY PCB ASS'Y	
15	FE4-8015-000		1	COVER, CONTROLLER OPTION	
16	FM1-U845-000		1	CABLE, SLEEP-CNT	
17	FM1-U847-000		1	CABLE, EPU-SLEEP	

Figure 110A POWER SUPPLY ASS'Y (100V, 120V)

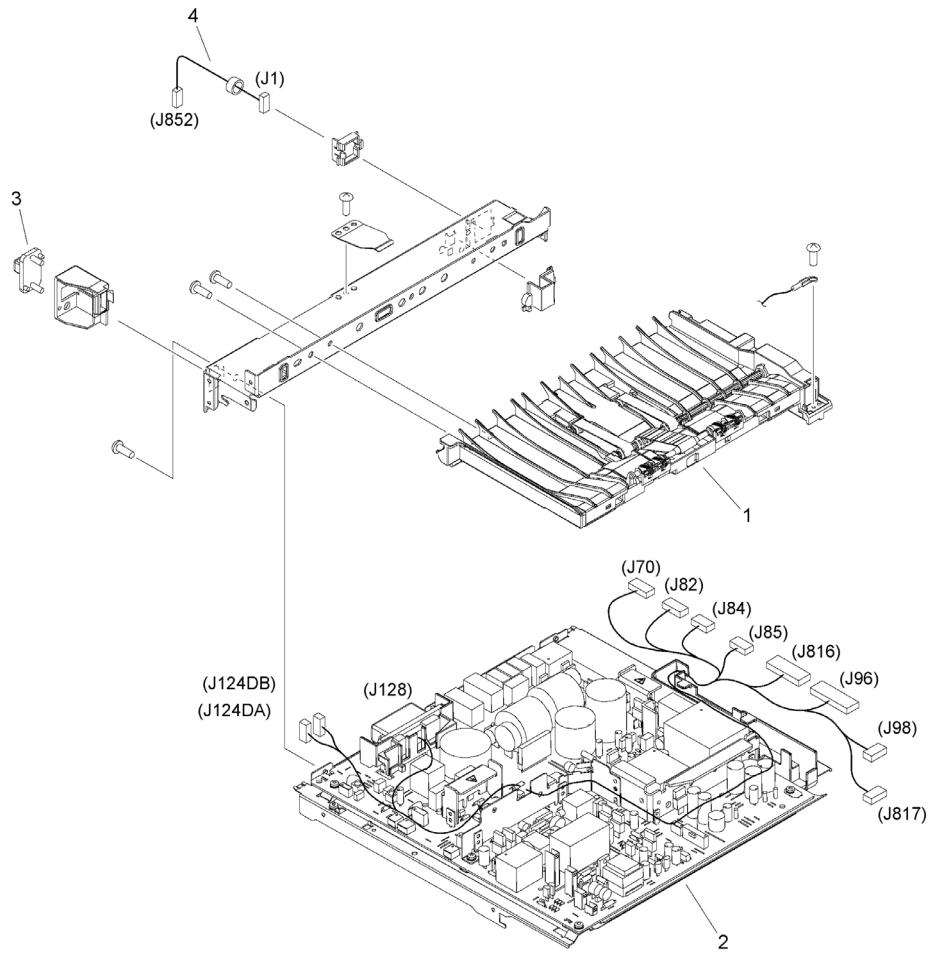

FIGURE & KEY NO.	PART NUMBER	RANK	QTY	DESCRIPTION	SERIAL NUMBER /REMARKS
110A	NPN		RF	POWER SUPPLY ASSY	100V, 120V
1	RM1-4548-000		1	PAPER FEED ASS'Y	
2	RM2-6301-000		1	ENGINE POWER SUPPLY PCB ASS'Y	
3	VS1-7514-006		1	CONNECTOR, DRAWER, 6P	
4	FM1-U841-000		1	CABLE, EPU INPUT	

Figure 110B POWER SUPPLY ASS'Y (230V)

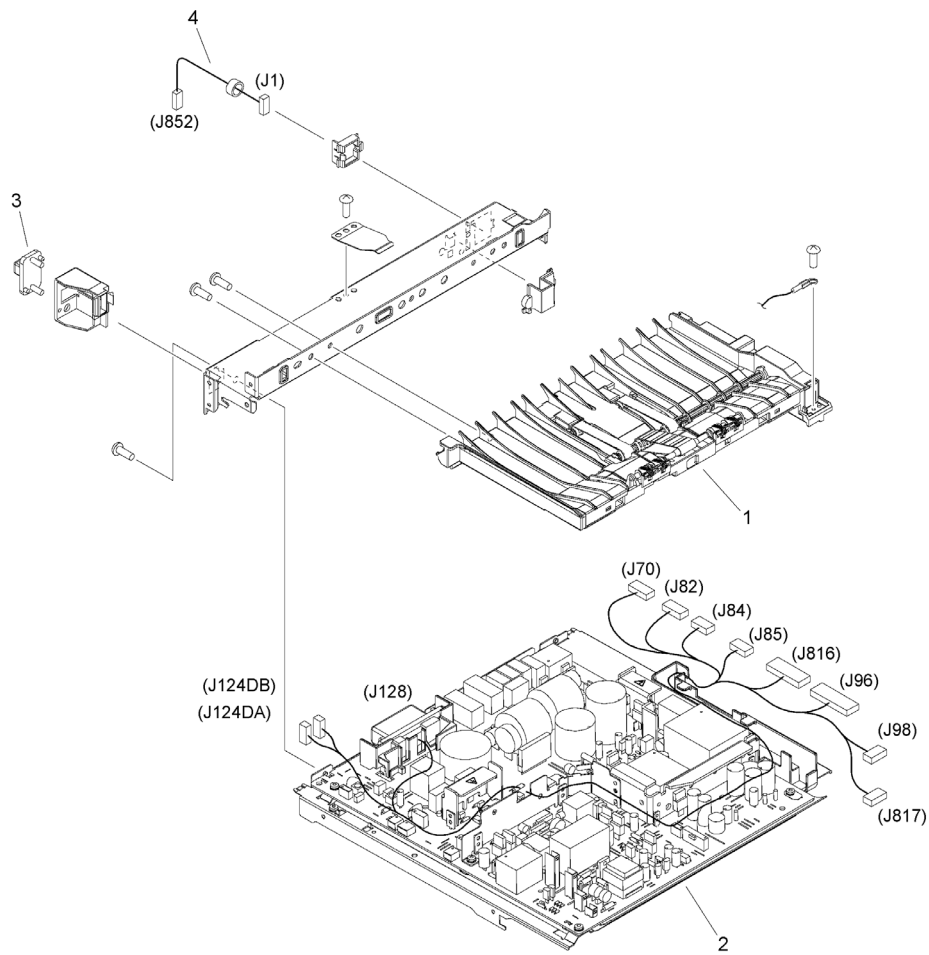

FIGURE & KEY NO.	PART NUMBER	RANK	QTY	DESCRIPTION	SERIAL NUMBER /REMARKS
110B	NPN		RF	POWER SUPPLY ASSY	230V
1	RM1-4548-000		1	PAPER FEED ASS'Y	
2	RM2-6349-000		1	ENGINE POWER SUPPLY PCB ASS'Y	
3	VS1-7514-006		1	CONNECTOR, DRAWER, 6P	
4	FM1-U841-000		1	CABLE, EPU INPUT	

Figure 330 MULTI-PURPOSE PICK-UP ASS'Y

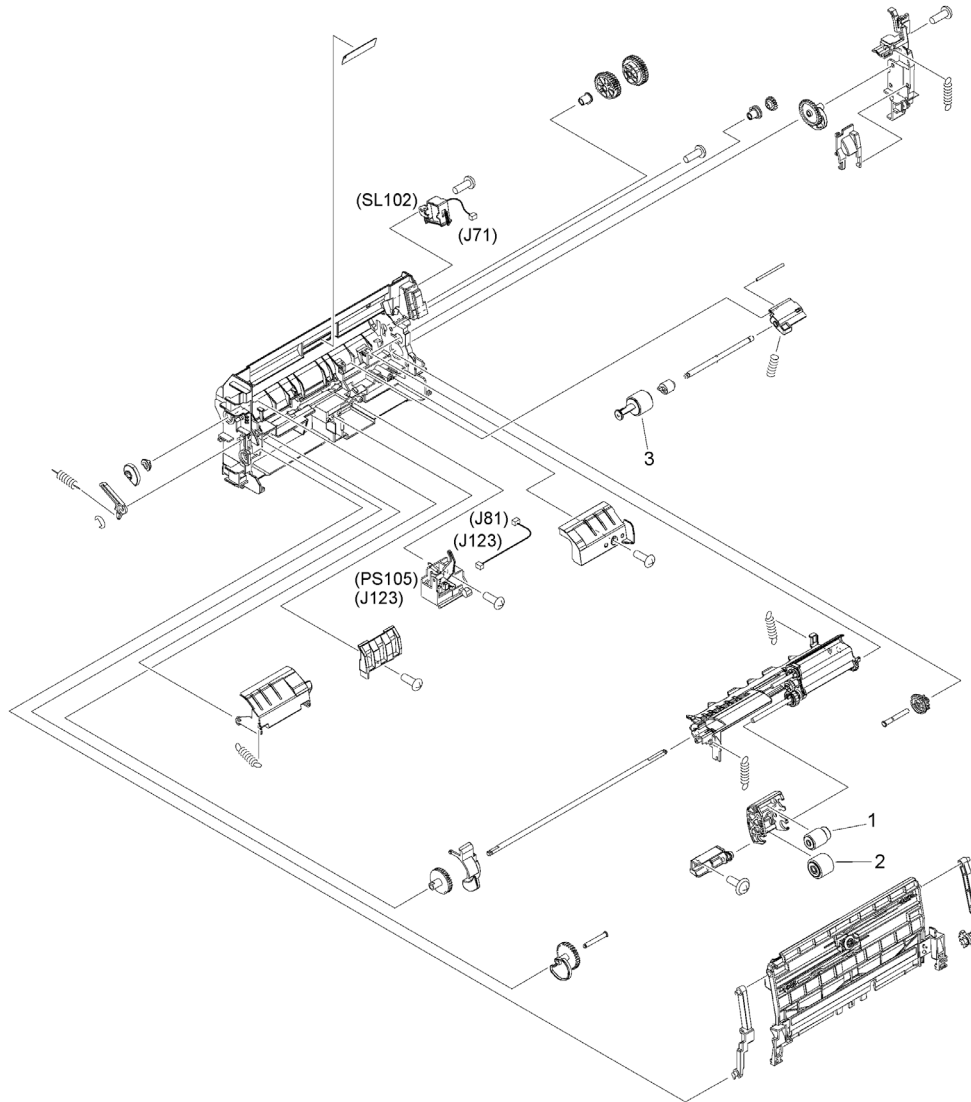

FIGURE & KEY NO.	PART NUMBER	R A N K	QTY	DESCRIPTION	SERIAL NUMBER /REMARKS
330	RM2-6323-000		1	MULTI-PURPOSE PICK-UP ASS'Y	
1	RL1-1641-000		1	ROLLER, PICK-UP	
2	RL1-1663-000		1	ROLLER, FEED	
3	RL1-1654-020		1	ROLLER, SEPARATION	

Figure 900C CONTROLLER PCB ASSEMBLY (LBP351dn, LBP351x)

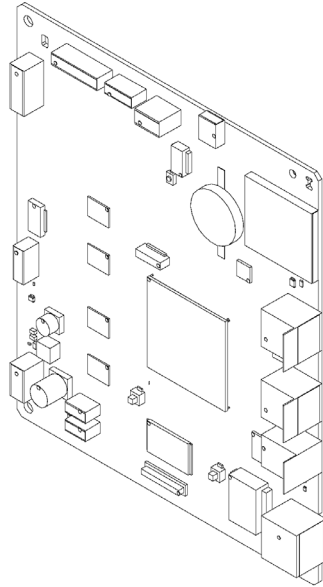

FIGURE & KEY NO.	PART NUMBER	R A N K	QTY	DESCRIPTION	SERIAL NUMBER /REMARKS
900C	FM1-U808-000		1	MAIN CONTROLLER PCB ASSEMBLY	LBP351dn,LBP351x
IC	FK3-1800-000		1	IC, ASIC, MB8AA4241EPBH-GE1	IC13

Figure 900D CONTROLLER PCB ASSEMBLY (LBP352dn, LBP352x)

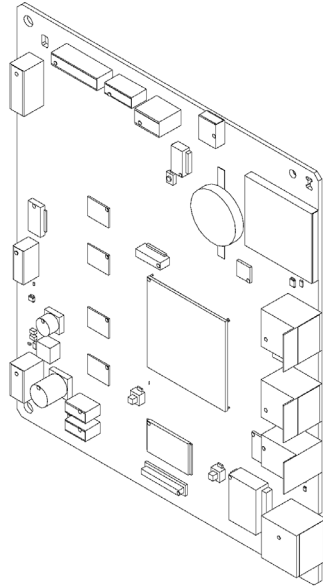

FIGURE & KEY NO.	PART NUMBER	RANK	QTY	DESCRIPTION	SERIAL NUMBER /REMARKS
900D	FM1-U809-000		1	MAIN CONTROLLER PCB ASSEMBLY	LBP352dn,LBP352x
IC	FK3-1800-000		1	IC, ASIC, MB8AA4241EPBH-GE1	IC13

Figure S10 DUPLEXING UNIT

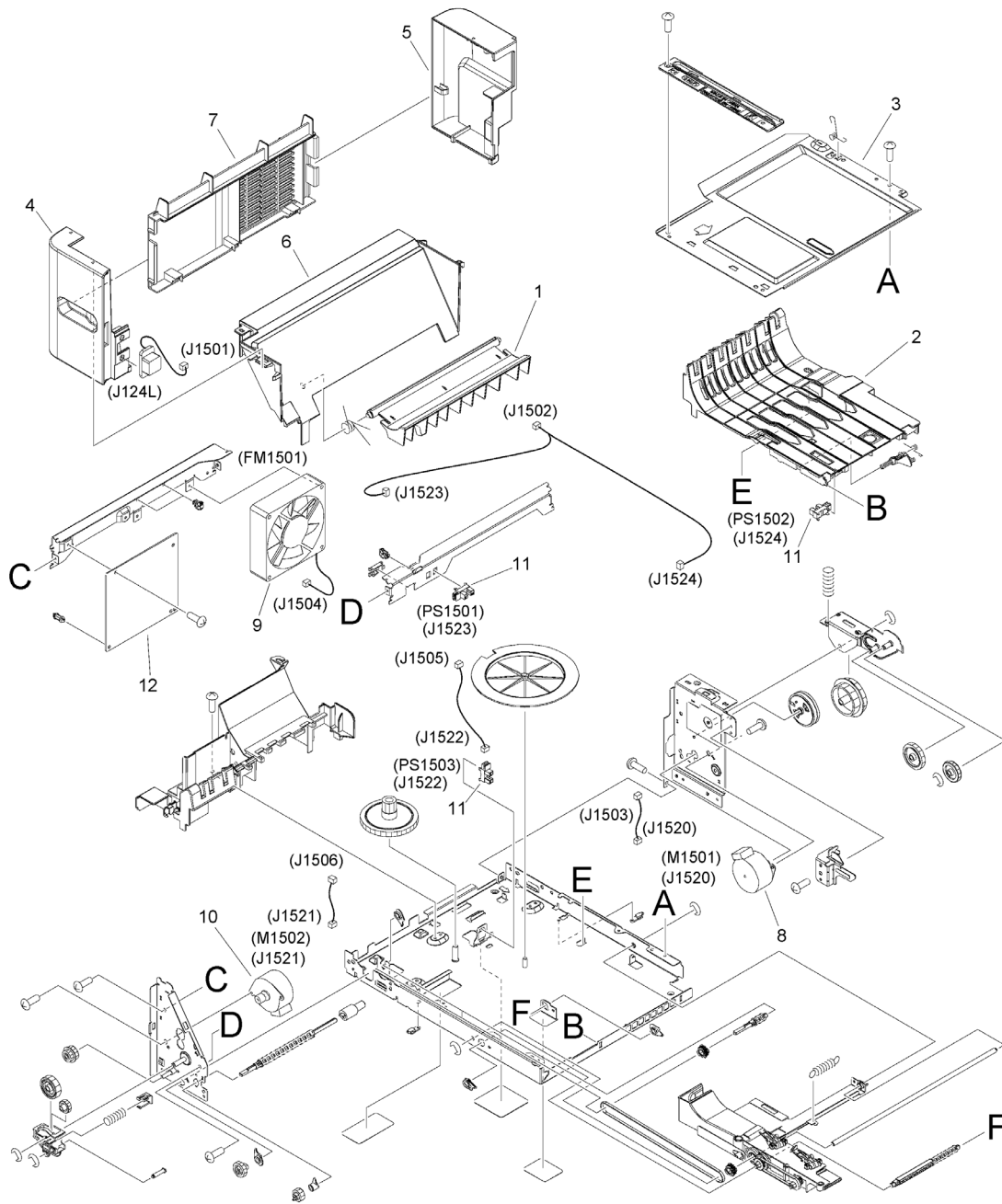

FIGURE & KEY NO.	PART NUMBER	RANK	QTY	DESCRIPTION	SERIAL NUMBER /REMARKS
S10	FM1-K577-010		1	DUPLEXING UNIT	
1	RC4-5907-000		1	DEFLECTOR, PAPER REPICK-UP	
2	RC2-2599-000		1	GUIDE, PAPER REPICK UP, LOWER	
3	RC2-2602-000		1	GUIDE, PAPER RE-PICK UP, UPPER	
4	FE4-8060-000		1	COVER, LEFT	
5	FE4-8061-000		1	COVER, RIGHT	
6	FE4-8059-000		1	COVER, UPPER	
7	FE4-8058-000		1	COVER, REAR	
8	RK2-7885-000		1	MOTOR, STEPPING, DC24V	M1501
9	RK2-2016-000		1	FAN	FM1501
10	RK2-2139-000		1	MOTOR, STEPPING, DC24V	M1502
11	WG8-5849-000		3	IC, PHOTO INTERRUPTER	PS1501, PS1502, PS1503
12	RM2-7656-000		1	DUPLEXING PCB ASS'Y	

Figure ZZA MECHANICAL STANDARD PARTS (HOW TO USE)

Mechanical standard parts 機械標準部品

About a mechanical standard parts

A Mechanical standard parts is a mechanical part which not parts peculiar to a product.
They are parts which are common to a Canon product and are used, such as a screw and a washer.
The Fig No. and parts number of the mechanical standard parts are not listed in the product parts catalog.
Refer to the parts catalog of mechanical standard parts when checking the parts number for screw or washer etc. and identify them by part shape or size.

機械標準部品とは

機械標準部品とは、製品特有の部品ではなく、ねじやワッシャなどキヤノン製品共通で使用されている機械部品（メカ部品）のことです。
製品のパーツカタログには、機械標準部品のFig No.や部品番号は記載していません。
ねじや、ワッシャ等の部品番号を調べるときは、機械標準部品のパーツカタログを参照し、部品の形状や大きさから判断し、使用している部品を調べてください。

Material and surface treatment of a mechanical standard parts

Material and surface treatment of mechanical standard parts are assigned commonly for each part.
Refer to the Table 1 for the parts which material and surface treatment are assigned as numbers.

機械標準部品の材料および表面処理

機械標準部品の材料および表面処理については、各種部品共通で決められています。
材料および表面処理が番号で決められている部品については、表1を参照してください。

Table 1 Material and Surface treatment
表1 材料および表面処理

No. 番号	Material 材料	Surface treatment 表面処理	Color 色
1	Stainless steel ステンレス	Stainless steel black coloring (BC4) ステンレス黒着色(BC4)	Black 黒
2		not to be given なし	White 白
3	Brass 黄銅	Regular nickel plating (NL) 普通ニッケルメッキ(NL)	White 白
4		Black nickel plating (BN) 黒色ニッケルメッキ(BN)	Black 黒
5	Steel 鋼	White zinc trivalent chromate treating (ZC3) 白色亜鉛3価クロメート(ZC3)	White 白
6		Regular nickel chromium plating (NC) 普通ニッケルクロムメッキ(NC)	White 白
7		Regular nickel plating (NL) 普通ニッケルメッキ(NL)	White 白
8		Iron and steel phosphating (P1) 鉄鋼燐酸塩処理(P1)	Black 黒
9		Black zinc trivalent chromate treating (BZ3) 黒色亜鉛3価クロメート(BZ3)	Black 黒

Figure ZZB (1/7)MECHANICAL STANDARD PARTS (SCREWS)

1. Screws
ねじ

How to read Parts Numbers
部品番号の見方

Screws
ねじ

XB1-2400-609

Type No.
類別番号
Normal designation (d)
ねじの呼び (d)
Length (L)
ねじの長さ (L)
Material and Surface treatment
材料および表面処理

XB1-2 expresses Binding head machine screw.
XB1-2は、バインドねじを表す
40 expresses M4.0.
40は、M4.0を表す
0-60 expresses a length of 6.0mm.
0-60は、6.0mmの長さを表す
9 expresses Steel (Black zinc trivalent chromate
treating) from Table 1.
9は、表1より鋼（黒色亜鉛3価クロメート）を表す

1-1. Cross Recessed Head Screws for Precision Equipments
精密機器用十字穴付き小ねじ

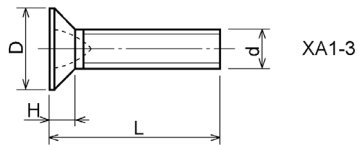
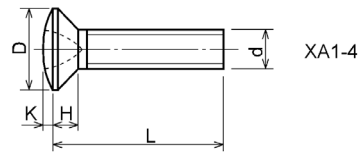
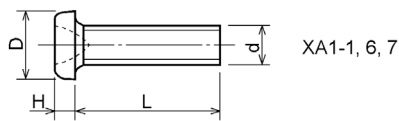

Type No. 類別番号	Type 類別	Head size (mm) 頭部寸法 (mm)						
		M1.4	M1.6	M1.7	M2	M2.5	M2.6	
XA1-1	Pan head Class 1 なべ1種	D	2	2.4	2.5	3	3.8	4
		H	0.5	0.55	0.5	0.6	0.9	0.8
XA1-3	Countersunk head Class 1 さら1種	D	2	2.4	2.5	3	3.8	4
		H	0.48	0.55	0.58	0.73	0.85	0.93
XA1-4	Oval countersunk head Class 1 丸さら1種	D	2	2.4	2.5	3	3.8	4
		H + K	0.68	0.8	0.88	1	1.25	1.3
XA1-6	Pan head Class 3 なべ3種	D	2.5	2.8	3	3.5	4.3	4.5
		H	0.8	0.85	0.9	1	1.3	1.2
XA1-7	Pan head Class 2 なべ2種	D	2.5	2.8	3	3.5	4.3	4.5
		H	0.5	0.55	0.5	0.6	0.9	0.8

Figure ZZB (2/7) MECHANICAL STANDARD PARTS (SCREWS)

1-2. Precision Tapping Screws
精密用タッピンねじ

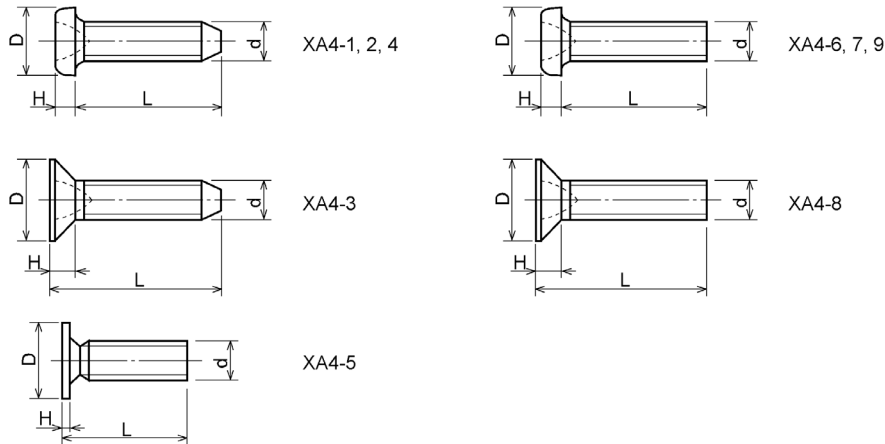

Type No. 類別番号	Type 類別	Head size (mm) 頭部寸法 (mm)						
		M1.4	M1.6	M1.7	M2	M2.5	M2.6	
XA4-1	With tapered end pan head Class 1 絞り-なべ1種	D XA4-1	2	2.4	2.5	3	3.8	4
		H XA4-1	0.5	0.55	0.5	0.6	0.9	0.8
XA4-2	With tapered end pan head Class 3 絞り-なべ3種	D XA4-2	2.5	2.8	3	3.5	4.3	4.5
		H XA4-2	0.8	0.85	0.9	1	1.3	1.2
XA4-3	With tapered end countersunk head 絞り-さら	D XA4-3	2	2.4	2.5	3	3.8	4
		H XA4-3	0.48	0.55	0.58	0.73	0.85	0.93
XA4-4	With tapered end pan head Class 2 絞り-なべ2種	D XA4-4	2.5	2.8	3	3.5	4.3	4.5
		H XA4-4	0.5	0.55	0.5	0.6	0.9	0.8
XA4-5	With parallel end ultra thin head ストレート-超薄頭	D XA4-5	2.5	2.8	3	-	-	-
		H XA4-5	0.2	0.2	0.2	-	-	-
XA4-6	With parallel end pan head Class 1 ストレート-なべ1種	D XA4-6	2	2.4	2.5	3	3.8	4
		H XA4-6	0.5	0.55	0.5	0.6	0.9	0.8
XA4-7	With parallel end pan head Class 3 ストレート-なべ3種	D XA4-7	2.5	2.8	3	3.5	4.3	4.5
		H XA4-7	0.8	0.85	0.9	1	1.3	1.2
XA4-8	With parallel end countersunk head ストレート-さら	D XA4-8	2	2.4	2.5	3	3.8	4
		H XA4-8	0.48	0.55	0.58	0.73	0.85	0.93
XA4-9	With parallel end pan head Class 2 ストレート-なべ2種	D XA4-9	2.5	2.8	3	3.5	4.3	4.5
		H XA4-9	0.5	0.55	0.5	0.6	0.9	0.8

Figure ZZB (3/7) MECHANICAL STANDARD PARTS (SCREWS)

1-3. Cross Recessed Head Screws
一般用十字穴付き小ねじ

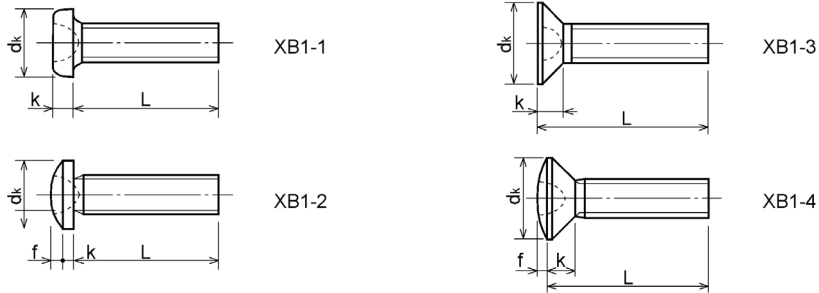

Type No. 類別番号	Type 類別
XB1-1	Pan head なべ
XB1-2	Binding head バインド
XB1-3	Countersunk head さら
XB1-4	Oval countersunk head 丸さら

		Head size (mm) 頭部寸法 (mm)					
		M2	M2.5	M2.6	M3	M4	M5
d_k	XB1-1	3.5	4.5	4.5	5.5	7	9
k	XB1-1	1.3	1.7	1.7	2	2.6	3.3
d_k	XB1-2	4.3	5.3	5.5	6.3	8.3	10.3
$k+f$	XB1-2	1.2	1.5	1.6	1.9	2.5	3.1
d_k	XB1-3	4	5	-	6	8	10
k	XB1-3	1.2	1.45	-	1.75	2.3	2.8
d_k	XB1-4	4	5	-	6	8	10
$k+f$	XB1-4	1.6	2	-	2.45	3.2	4
Screw part length ねじ部長さ b		8	12	12	12	16	20

Figure ZZB (4/7) MECHANICAL STANDARD PARTS (SCREWS)

1-4. Cross Recessed Head Screws with Captive Washer
座金組込み十字穴付き小ねじ

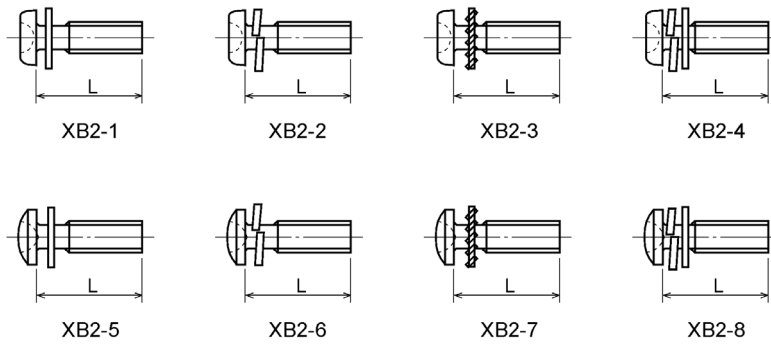

Type No. 類別番号	Type 類別
XB2-1	Pan head + Plain washer (circular bright) なべねじ+平座金
XB2-2	Pan head + Spring washer なべねじ+ばね座金
XB2-3	Pan head + Toothed lock washer なべねじ+歯付座金
XB2-4	Pan head + Spring washer and plain washer (circular bright) なべねじ+(ばね+平)座金
XB2-5	Binding head + Plain washer (circular bright) バインドねじ+平座金
XB2-6	Binding head + Spring washer バインドねじ+ばね座金
XB2-7	Binding head + Toothed lock washer バインドねじ+歯付座金
XB2-8	Binding head + Spring washer and plain washer (circular bright) バインドねじ+(ばね+平)座金

Figure ZZB (5/7) MECHANICAL STANDARD PARTS (SCREWS)

1-5. Hexagon Head Tapping Screws for Matallic Materials
 金属用六角タッピンねじ

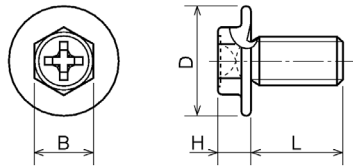

Type No. 類別番号	Type 類別	Head size (mm) 頭部寸法 (mm)		
		M3	M4	
XB3-6	For metallic materials 金属用タッピン	D	8	10
		B	5.5	5.5
XB3-7	For metallic materials with clawed 金属用タッピン-つめ付き	H XB3-6	3.1	3.1
		H XB3-7	3.2	3.2

1-6. Special Tapping Screws
 特殊タッピンねじ

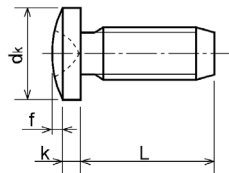

Type No. 類別番号	Type 類別	Head size (mm) 頭部寸法 (mm)		
		M3	M4	
XB4-5	Binding head バインド	dk	6.3	8.3
		k	1.3	1.7
		k+f	1.9	2.5

Figure ZZB (6/7) MECHANICAL STANDARD PARTS (SCREWS)

1-7. General Head Tapping Screws
一般用タッピンねじ

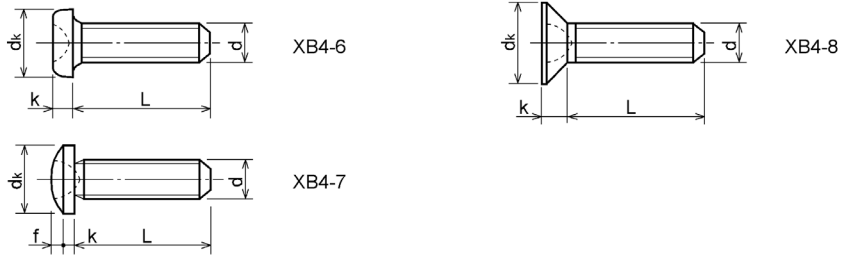

Type No. 類別番号	Type 類別	Head size (mm) 頭部寸法 (mm)						
		M2	M2.5	M2.6	M3	M4	M5	
XB4-6	Pan head なべ	dk XB4-6	3.5	4.5	4.5	5.5	7	9
		k XB4-6	1.3	1.7	1.7	2	2.6	3.3
XB4-7	Binding head バインド	dk XB4-7	4.3	5.3	5.5	6.3	8.3	10.3
		k+f XB4-7	1.2	1.5	1.6	1.9	2.5	3.1
XB4-8	Countersunk head さら	dk XB4-8	4	5	5.2	6	8	10
		k XB4-8	1.2	1.45	1.5	1.75	2.3	2.8

1-8. Tapping Screws for Metallic Materials
金属用タッピンねじ

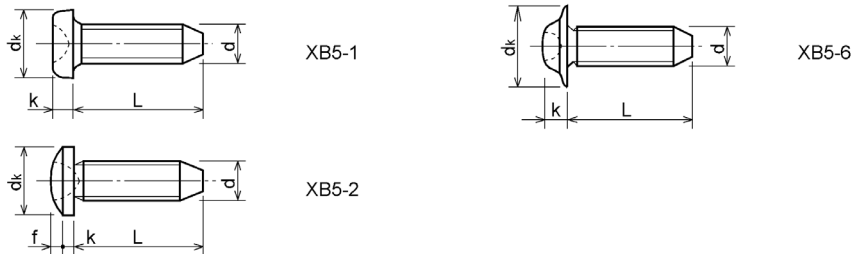

Type No. 類別番号	Type 類別	Head size (mm) 頭部寸法 (mm)					
		M2.5	M2.6	M3	M4	M5	
XB5-1	Pan head なべ	dk XB5-1	4.5	4.5	5.5	7	9
		k XB5-1	1.7	1.7	2	2.6	3.3
XB5-2	Binding head バインド	dk XB5-2	5.5	5.5	6.3	8.3	10.3
		k+f XB5-2	1.6	1.6	1.9	2.5	3.1
XB5-6	Flanged pan head つば付きなべ	dk XB5-6	6.5	6.5	8	10	12
		k XB5-6	2.1	2.1	1.75	3.2	4

Figure ZZB (7/7) MECHANICAL STANDARD PARTS (SCREWS)

1-9. Hexagon Socket Set Screws
六角穴付き止めねじ

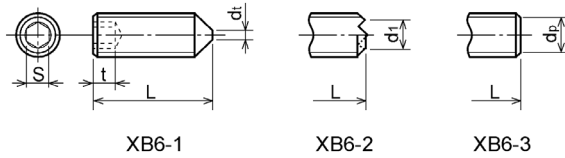

Type No. 類別番号	Type 類別	Head size (mm) 頭部寸法 (mm)						
		M1.6 M1.7	M2	M2.5 M2.6	M3	M5	M5	M6
	S	0.7	0.9	1.3	1.5	2	2.5	3
	t	1.5	1.7	2	2	2.5	3	3.5
	dt max XB6-1	0.4	0.5	0.65	0.75	1	1.25	1.5
	d1 max XB6-2	-	1.2	1.5	1.7	2.2	2.8	3.3
	d1 min XB6-2	-	1	1.2	1.4	1.9	2.4	2.9
	dp max XB6-3	0.8	1	1.5	2	2.5	3.5	4
	dp min XB6-3	0.55	0.75	1.25	1.75	2.25	3.2	3.7

1-10. Flanged Pan Head Machine Screws
つば付きなべ小ねじ

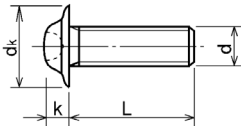

Type No. 類別番号	Type 類別	Head size (mm) 頭部寸法 (mm)				
		M2	M2.5 M2.6	M3	M5	M5
	dk	5	6.5	8	10	12
	k	1.7	2.1	2.5	3.2	4

Figure ZZC MECHANICAL STANDARD PARTS (BOLTS)

2. Bolts (Socket head cap screw)
ボルト

How to read Parts Numbers
部品番号の見方

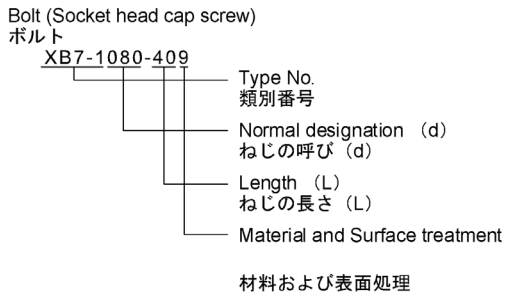

XB7-1 expresses Hexagon socket head cap screws.
XB7-1は、六角穴付きボルトを表す

080 expresses M8.0.
080は、M8.0を表す

40 expresses a length of 40mm.
40は、40mmの長さを表す

9 expresses Steel (Black zinc trivalent chromate treating) from Table 1.
9は、表1より鋼（黒色亜鉛3価クロメート）を表す

2-1. Hexagon socket head cap screws
六角穴付きボルト

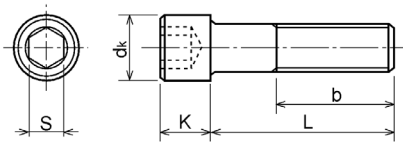

Type No. 類別番号	Type 類別
XB7-1	Hexagon socket head cap screws 六角穴付きボルト

	Head size (mm) 頭部寸法 (mm)						
	M3	M4	M5	M6	M8	M10	M12
S	2.5	3	4	5	6	8	10
dk	5.5	7	8.5	10	13	16	18
K	3	4	5	6	8	10	12
Screw part length ねじ部長さ b_{max}	18	20	22	24	28	32	36

Figure ZZD MECHANICAL STANDARD PARTS (NUTS)

3. Nuts
ナット

How to read Parts Numbers
部品番号の見方

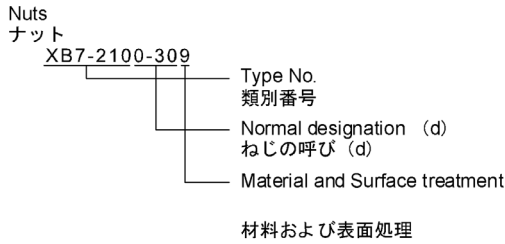

XB7-210 expresses Hexagon nut class 1.
XB7-210は、六角ナット1種を表す

0-30 expresses M3.0.
0-30は、M3.0を表す

9 expresses Steel (Black zinc trivalent chromate treating) from Table 1.
9は、表1より鋼（黒色亜鉛3価クロメート）を表す

3-1. Hexagon Nuts and Hexagon Thin Nuts
六角ナット

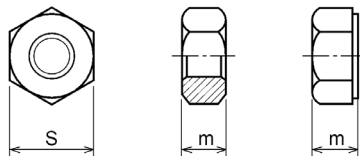

Type No. 類別番号	Type 類別
XB7-210	Hexagon nut Class 1 六角ナット-1種
XB7-220	Hexagon nut Class 3 六角ナット-3種
XB7-230	Hexagon nut Style 1 double chamfered 六角ナット-スタイル1-両面とり
XB7-231	Hexagon nut Style 1 washer faced 六角ナット-スタイル1-座付き
XB7-240	Hexagon nut Style 2 double chamfered 六角ナット-スタイル2-両面とり
XB7-241	Hexagon nut Style 2 washer faced 六角ナット-スタイル2-座付き
XB7-250	Hexagon nut 六角ナット
XB7-260	Hexagon thin nut double chamfered 六角低ナット-両面とり
XB7-270	Hexagon thin nut not chamfered 六角低ナット-面とり無し

	Head size (mm) 頭部寸法 (mm)						
	M2	M2.5	M3	M4	M5	M6	M8
S	4	5	5.5	7	8	10	13
m XB7-210	1.6	2	2.4	3.2	4	5	6.5
m XB7-220	1.2	1.6	1.8	2.4	3.2	3.6	5
m XB7-230, 231	1.6	2	2.4	3.2	4.7	5.2	6.8
m XB7-240, 241	-	-	-	-	5.1	5.7	7.5
m XB7-250	-	-	-	-	5.6	6.1	7.9
m XB7-260	1.2	1.6	1.8	2.2	2.7	3.2	4
m XB7-270	1.2	1.6	1.8	2.2	2.7	3.2	4

Figure ZZE (1/3)MECHANICAL STANDARD PARTS (RETAINING RINGS)

5. Retaining Rings
止め輪

How to read Parts Numbers
部品番号の見方

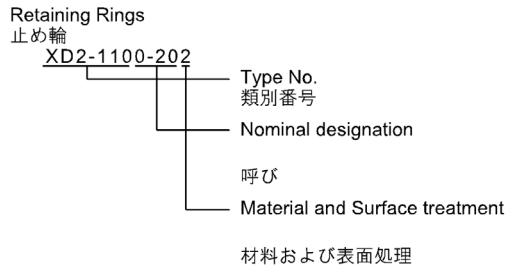

XD2-110 expresses retaining ring-E type (Type1).
XD2-110は、E形止め輪（1種）を表す

0-20 expresses a 020 of nominal designation.
(See Table 5)
0-20は、呼び020を表す（表5参照）

2 expresses Stainless steel (Surface treatment is not to be given) from Table 1.
2は、表1よりステンレス（表面処理なし）を表す

5-1. Retaining Rings - E type
E形止め輪

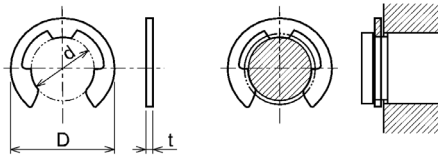

Type No. 類別番号	Type 類別
XD2-110	Retaining ring - E type (Type 1) E形止め輪（1種）
XD2-120	Retaining ring - E type (Type 2) E形止め輪（2種）

Table 5 表5

Type 種類	Nominal designation 呼び	d (mm)	D (mm)	t (mm)
Type 1 1種	007	0.65	2	0.2
	010	0.95	2.8	0.2
	013	1.25	3.3	0.3
	017	1.65	4.2	0.4
	020	1.95	4.6	0.5
	024	2.35	6	0.6
	028	2.74	6.5	0.6
	032	3.14	7.2	0.6
	037	3.64	8	0.7
	040	3.93	10	0.7
	042	4.13	10	0.7
	050	4.93	11	0.7
	058	5.73	12	0.7
	060	5.93	12.7	0.9
064	6.32	13.5	0.9	
074	7.31	15	0.9	
080	7.91	16.5	1	
Type 2 2種	008	0.8	2	0.2
	012	1.2	3	0.3
	015	1.5	4	0.4
	020	2	5	0.4
	025	2.5	6	0.4
	030	3	7	0.6
	040	4	9	0.6
	050	5	11	0.6
	060	6	12	0.8
	070	7	14	0.8
	080	8	16	0.8
	090	9	18	0.8
100	10	20	1	

Figure ZZE (2/3)MECHANICAL STANDARD PARTS (RETAINING RINGS)

5-2. Grip Rings
グリップ止め輪

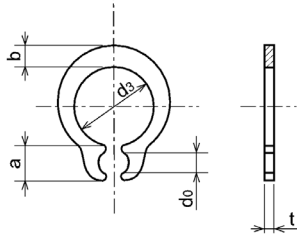

Table 5 表5

Nominal designation 呼び	d_3 (mm)	t (mm)	b (mm)	a (mm)	d_o (mm)
020	1.9	0.5	1	1.8	0.8
025	2.35	0.5	1.2	1.9	0.9
030	2.85	0.6	1.4	1.9	0.9
035	3.3	0.6	1.6	2	0.9
040	3.8	0.8	1.8	2.8	1.2
045	4.25	0.8	2	2.9	1.3
050	4.75	0.8	2.2	2.9	1.3
060	5.7	1	2.4	3.1	1.4
070	6.7	1	2.7	3.3	1.4
080	7.7	1	3	3.5	1.4
090	8.65	1.2	3.3	4.7	1.5
100	9.65	1.2	3.5	4.7	2

Type No. 類別番号	Type 類別
XD2-210	Grip ring グリップ止め輪

5-3. Toothed Retaining Rings
歯付き形止め輪

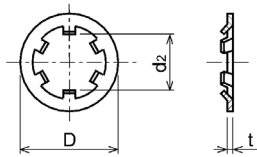

Table 5 表5

Nominal designation 呼び	d_z (mm)	D (mm)	t (mm)	No of teeth 歯数
015	1.4	5.2	0.25	3
020	1.9	6	0.25	3
024	2.3	6.4	0.25	3
030	2.8	8	0.25	4
040	3.8	9	0.25	4
050	4.8	10	0.25	5
060	5.8	11	0.25	5
080	7.8	13	0.25	5
100	9.8	15.4	0.25	6

Type No. 類別番号	Type 類別
XD2-230	Toothed retaining ring 歯付き形止め輪

Figure ZZE (3/3)MECHANICAL STANDARD PARTS (RETAINING RINGS)

5-4. Retaining Rings - C Type
C形止め輪

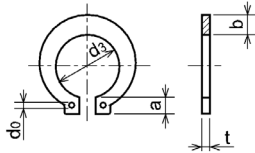

Type No. 類別番号	Type 類別
XD2-310	Retaining ring - C type for shaft C形止め輪 軸用

Table 5 表5

Nominal designation 呼び	d ₃ (mm)	t (mm)	b (mm)	a (mm)	d ₀ (mm)
010	9.3	1	1.6	3	1.2
012	11.1	1	1.8	3.2	1.5
014	12.9	1	2	3.4	1.7
015	13.8	1	2.1	3.5	1.7
016	14.7	1	2.2	3.6	1.7
017	15.7	1	2.2	3.7	1.7
018	16.5	1.2	2.6	3.8	1.7
020	18.5	1.2	2.7	3.9	2
022	20.5	1.2	2.7	4.1	2
025	23.2	1.2	3.1	4.3	2
028	25.9	1.5	3.1	4.6	2
030	27.9	1.5	3.5	4.8	2
032	29.6	1.5	3.5	5	2.5
035	32.2	1.5	4	5.4	2.5

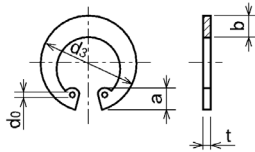

Type No. 類別番号	Type 類別
XD2-320	Retaining ring - C type for hole C形止め輪 穴用

Table 5 表5

Nominal designation 呼び	d ₃ (mm)	t (mm)	b (mm)	a (mm)	d ₀ (mm)
010	10.7	1	1.8	3.1	1.2
011	11.8	1	1.8	3.2	1.2
012	13	1	1.8	3.3	1.5
014	15.1	1	2	3.6	1.7
016	17.3	1	2	3.7	1.7
018	19.5	1	2.5	4	1.7
019	20.5	1	2.5	4	2
020	21.5	1	2.5	4	2
022	23.5	1	2.5	4.1	2
025	26.9	1.2	3	4.4	2
028	30.1	1.2	3	4.6	2
030	32.1	1.2	3	4.7	2
032	34.4	1.2	3.5	5.2	2.5
035	37.8	1.5	3.5	5.2	2.5
037	39.8	1.5	3.5	5.2	2.5
040	43.5	1.8	4	5.7	2.5
042	45.5	1.8	4	5.8	2.5
045	48.5	1.8	4.5	5.9	2.5
047	50.5	1.8	4.5	6.1	2.5
050	54.2	2	4.5	6.5	2.5
052	56.2	2	5.1	6.5	2.5
055	59.2	2	5.1	6.5	2.5
060	64.2	2	5.1	6.8	2.5
062	66.2	2	5.5	6.9	2.5
068	72.5	2.5	6	7.4	2.5
072	76.5	2.5	6.6	7.4	2.5
075	79.5	2.5	6.6	7.8	2.5
080	85.5	2.5	7	8	2.5
085	90.5	3	7	8	3
090	95.5	3	7.6	8.3	3
095	100.5	3	8	8.5	3