

POD Deck Lite-A1

SERVICE MANUAL



Canon

September 30, 2009

Rev. 0

Application

This manual has been issued by Canon Inc. for qualified persons to learn technical theory, installation, maintenance, and repair of products. This manual covers all localities where the products are sold. For this reason, there may be information in this manual that does not apply to your locality.

Corrections

This manual may contain technical inaccuracies or typographical errors due to improvements or changes in products. When changes occur in applicable products or in the contents of this manual, Canon will release technical information as the need arises. In the event of major changes in the contents of this manual over a long or short period, Canon will issue a new edition of this manual.

The following paragraph does not apply to any countries where such provisions are inconsistent with local law.

Trademarks

The product names and company names used in this manual are the registered trademarks of the individual companies.

Copyright

This manual is copyrighted with all rights reserved. Under the copyright laws, this manual may not be copied, reproduced or translated into another language, in whole or in part, without the written consent of Canon Inc.

COPYRIGHT © 2001 CANON INC.









Printed in Japan

Caution

Use of this manual should be strictly supervised to avoid disclosure of confidential information.



Symbols Used

This documentation uses the following symbols to indicate special information:

Symbol	Description
	Indicates an item of a non-specific nature, possibly classified as Note, Caution, or Warning.
	Indicates an item requiring care to avoid electric shocks.
	Indicates an item requiring care to avoid combustion (fire).
	Indicates an item prohibiting disassembly to avoid electric shocks or problems.
	Indicates an item requiring disconnection of the power plug from the electric outlet.
 Memo	Indicates an item intended to provide notes assisting the understanding of the topic in question.
 REF.	Indicates an item of reference assisting the understanding of the topic in question.
	Provides a description of a service mode.
	Provides a description of the nature of an error indication.

The following rules apply throughout this Service Manual:

1. Each chapter contains sections explaining the purpose of specific functions and the relationship between electrical and mechanical systems with reference to the timing of operation.

In the diagrams,  represents the path of mechanical drive; where a signal name accompanies the symbol, the arrow  indicates the direction of the electric signal.

The expression "turn on the power" means flipping on the power switch, closing the front door, and closing the delivery unit door, which results in supplying the machine with power.

2. In the digital circuits, '1' is used to indicate that the voltage level of a given signal is "High", while '0' is used to indicate "Low". (The voltage value, however, differs from circuit to circuit.) In addition, the asterisk (*) as in "DRMD*" indicates that the DRMD signal goes on when '0'.

In practically all cases, the internal mechanisms of a microprocessor cannot be checked in the field. Therefore, the operations of the microprocessors used in the machines are not discussed: they are explained in terms of from sensors to the input of the DC controller PCB and from the output of the DC controller PCB to the loads.

The descriptions in this Service Manual are subject to change without notice for product improvement or other purposes, and major changes will be communicated in the form of Service Information bulletins.

All service persons are expected to have a good understanding of the contents of this Service Manual and all relevant Service Information bulletins and be able to identify and isolate faults in the machine."

Contents

Chapter 1 Specifications

1.1 Product Specifications	1- 1
1.1.1 Specifications	1- 1
1.2 Names of Parts	1- 2
1.2.1 External View.....	1- 2
1.2.2 Cross Section	1- 2

Chapter 2 Installation

2.1 Installation Procedure	2- 1
2.1.1 Turning OFF the Host Machine	2- 1
2.1.2 Installation Procedure.....	2- 1
2.1.3 Affixing of Labels	2- 9
2.2 Making Adjustments	2- 10
2.2.1 Switching the Paper Size.....	2- 10
2.3 Checking the Operation	2- 10
2.3.1 Cable connection.....	2- 10
2.3.2 Adjustment of side registration (image write-start position in main scanning direction)	2- 10

Chapter 3 Functions

3.1 Basic Construction.....	3- 1
3.1.1 Functional Construction.....	3- 1
3.1.2 Overview of the Electrical Circuitry	3- 1
3.2 Pick-Up/Feed System	3- 2
3.2.1 Overview.....	3- 2
3.2.2 Pickup Operation	3- 2
3.3 Paper Detection	3- 3
3.3.1 Paper Level Detection	3- 3
3.3.2 Detecting the Presence/Absence of Paper.....	3- 4
3.3.3 Switching the Paper Size.....	3- 4
3.4 Deck Lifter	3- 4
3.4.1 Overview.....	3- 4
3.4.2 Controlling the Lifter	3- 5
3.4.3 Indicating the Level of Paper on the Deck Front Cover.....	3- 5
3.5 Opening /Closing the Compartment	3- 6
3.5.1 Opening and Closing of the Compartment	3- 6
3.5.2 Sequence of Operations (opening/closing)	3- 6
3.6 Air Assist Control	3- 7
3.6.1 Overview.....	3- 7
3.6.2 Controlling the Air Separation Mechanism	3- 7
3.6.3 Swing Movement	3- 8
3.7 Detecting Jams	3- 9
3.7.1 Overview.....	3- 9
3.7.2 Types of Jams	3- 9
3.7.3 Sequence of Operations Used to Detect Jams	3- 10
3.8 Power Supply	3- 11
3.8.1 Power Supply	3- 11
3.8.2 Protection Function.....	3- 11
3.9 Fan	3- 12

3.9.1 Overview	3- 12
Chapter 4 Parts Replacement Procedure	
4.1 Removing from the Host Machine	4- 1
4.1.1 Compartment	4- 1
4.1.1.1 Removing from the Host Machine.....	4- 1
4.1.1.2 Removing the Compartment	4- 2
4.2 External Covers	4- 3
4.2.1 Rear Cover.....	4- 3
4.2.1.1 Removing the Rear Cover	4- 3
4.2.2 Right Cover	4- 4
4.2.2.1 Removing the Right Cover.....	4- 4
4.2.3 Upper Cover.....	4- 4
4.2.3.1 Removing the Upper Cover	4- 4
4.3 Drive System	4- 5
4.3.1 Pickup Motor	4- 5
4.3.1.1 Preparation for Removing the Deck Pickup Motor.....	4- 5
4.3.1.2 Removing the Deck Pickup Motor.....	4- 5
4.3.2 Deck Pickup Clutch.....	4- 6
4.3.2.1 Preparation for Removing the Deck Pickup Clutch.....	4- 6
4.3.2.2 Removing the Deck Pickup Clutch.....	4- 6
4.3.3 Deck Lifter Motor.....	4- 6
4.3.3.1 Preparation for Removing the Deck Lifter Motor.....	4- 6
4.3.3.2 Removing the Deck Lifter Motor	4- 6
4.3.4 Lifter Cable (Front).....	4- 7
4.3.4.1 Preparation for Removing the Lifter Cable (front).....	4- 7
4.3.4.2 Removing the Lifter Cable (front).....	4- 8
4.3.4.3 Routing the Lifter Cable	4- 8
4.3.5 Lifter Cable.....	4- 10
4.3.5.1 Preparation for Removing the Lifter Cable (rear).....	4- 10
4.3.5.2 Removing the Lifter Cable (rear).....	4- 10
4.3.5.3 Routing the Lifter Cable	4- 11
4.3.6 Swing Motor	4- 13
4.3.6.1 Preparation for Removing the Swing Motor.....	4- 13
4.3.6.2 Removing the Swing Motor	4- 13
4.4 Document Feeding System	4- 14
4.4.1 Deck Pickup Unit.....	4- 14
4.4.1.1 Preparation for Removing the Deck Pickup Unit.....	4- 14
4.4.1.2 Removing the Deck Pickup Unit	4- 14
4.4.2 Deck Pickup Roller.....	4- 14
4.4.2.1 Preparation for Removing the Deck Pickup Unit.....	4- 14
4.4.2.2 Removing the Deck Pickup Roller	4- 14
4.4.3 Deck Pickup/Feed Roller	4- 14
4.4.3.1 Preparation for Removing the Deck Pickup/Feed Roller	4- 14
4.4.3.2 Removing the Deck Pickup/Feed Roller	4- 14
4.4.4 Deck Separation Roller.....	4- 14
4.4.4.1 Removing the Deck Separation Roller.....	4- 14
4.5 Electrical System	4- 15
4.5.1 Fan.....	4- 15
4.5.1.1 Preparation for Removing the Cooling Fan/Warming Fan/Additional Fan	4- 15
4.5.1.2 Removing the Cooling Fan	4- 15
4.5.1.3 Removing the Warming Fan	4- 15
4.5.1.4 Removing the Additional Fan.....	4- 15
4.5.1.5 Preparation for Removing the Motor Cooling Fan	4- 16
4.5.1.6 Removing the Motor Cooling Fan	4- 16
4.5.2 Box Controller PCB.....	4- 16
4.5.2.1 Preparation for Removing the Box Driver PCB.....	4- 16
4.5.2.2 Removing the Box Driver PCB.....	4- 16

4.5.3 Deck Controller PCB	4- 16
4.5.3.1 Preparation for Removing the Deck Controller PCB.....	4- 16
4.5.3.2 Removing the Deck Controller PCB.....	4- 16
4.5.4 Open Switch PCB.....	4- 17
4.5.4.1 Preparation for Removing the Open Switch PCB	4- 17
4.5.4.2 Removing the Open Switch PCB.....	4- 17
4.5.5 Environmental Sensor	4- 18
4.5.5.1 Preparation for Removing the Environment Sensor	4- 18
4.5.5.2 Removing the Environment Sensor	4- 18
4.5.6 DC Power Supply PCB.....	4- 18
4.5.6.1 Preparation for Removing the DC Power Supply PCB	4- 18
4.5.6.2 Removing the DC Power Supply PCB.....	4- 18
4.5.7 Deck Heater.....	4- 18
4.5.7.1 Preparation for Removing the Cassette Heater	4- 18
4.5.7.2 Removing the Cassette Heater.....	4- 18
4.5.8 Air Heater	4- 18
4.5.8.1 Preparation for Removing the Air Heater.....	4- 18
4.5.8.2 Removing the Air Heater.....	4- 19

Chapter 5 Maintenance

5.1 Maintenance and Inspection.....	5- 1
5.1.1 Periodically Replaced Parts.....	5- 1
5.1.1.1 Periodically Replaced Parts	5- 1
5.1.2 Durables	5- 1
5.1.2.1 Consumables and Durables.....	5- 1
5.1.3 Periodical Servicing	5- 1
5.1.3.1 Scheduled Servicing	5- 1
5.2 Adjustment.....	5- 1
5.2.1 Basic Adjustment.....	5- 1
5.2.1.1 Position of the Front Cover	5- 1
5.2.1.2 Adjusting the Registration	5- 1
5.2.1.3 Adjusting the Position of the wheel.....	5- 2
5.2.1.4 Adjusting the Pressure of the Deck Separation Roller.....	5- 3
5.2.1.5 Position of the Deck Pickup Roller Release Solenoid.....	5- 3
5.2.1.6 Orientation of the Pickup Roller	5- 3
5.2.1.7 Orientation of the Feed Roller.....	5- 3
5.2.2 Adjustment at Time of Parts Replacement	5- 4
5.2.2.1 Routing the Lifter Cable	5- 4
5.3 Outline of Electrical Components	5- 5
5.3.1 Clutches/Solenoids.....	5- 5
5.3.2 Motors/Fans.....	5- 6
5.3.3 Sensors/Switches	5- 7
5.3.4 Heaters/Others	5- 8
5.3.5 PCBs	5- 9
5.4 Variable Resistors (VR), Light-Emitting Diodes (LED), and Check Pins by PCB.....	5- 10
5.4.1 Deck controller PCB	5- 10
5.4.2 Box driver PCB	5- 10

Chapter 6 Error Code

6.1 Service Error Code	6- 1
6.1.1 Outline	6- 1

Chapter 1 Specifications

Contents

1.1 Product Specifications.....	1-1
1.1.1 Specifications	1-1
1.2 Names of Parts	1-2
1.2.1 External View	1-2
1.2.2 Cross Section	1-2

1.1 Product Specifications

1.1.1 Specifications

T-1-1

Item	Description
Pickup method	retard separation + air (switches between warm and cool currents to suit paper type/environment)
Paper accommodation	front loading
Copy paper type	thin paper (equivalent of 52 to 63 g/m ²) plain paper 1 (equivalent of 64 to 90 g/m ²) plain paper 2 (equivalent of 91 to 105 g/m ²) heavy paper 1 (equivalent of 106 to 150 g/m ²) heavy paper 2 (equivalent of 151 to 220 g/m ²) heavy paper 3 (equivalent of 221 to 256 g/m ²) heavy paper 4 (equivalent of 257 to 300 g/m ²) coated paper (equivalent of 80 to 300 g/m ²) transparency, colored paper, recycled paper, bond paper, embossed paper, label paper
Copy paper size	13" x 19" (330.2 x 482.6 mm), 12" x 18" (304.8 x 457.2 mm), SRA3 (320 x 450 mm), A3, A4, A4R, B4, B5, LDR, LGL, LTR, LTR-R
Stack height (number of sheets)	375.5 mm (height to bottom of arrow on Stack Limit label) number of sheets : about 3500 (equivalent of 80 g/m ²)
Size switching	by partition plate (in steps) + size input from control panel of host machine
Paper detection	yes
Control angle	compartment button
Display	no (shares key on host machine)
Ecological consideration	environment sensor, air heater, deck sheet
Dimensions	(W) 601 x (D) 621 x (H) 570 mm
Weight	about 51 kg
Power supply	AC power supply by outlet
Operating noise	host machine noise + 3 dB
Air separation fan	yes
Heater for air separation fan	yes

1.2 Names of Parts

1.2.1 External View

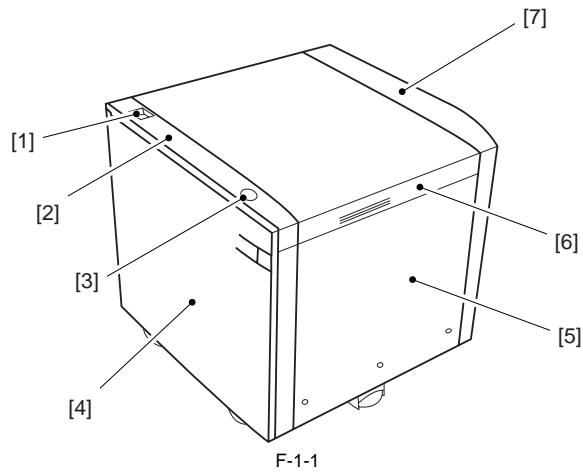

- | | |
|-----------------------------|-----------------|
| [1] Deck releasing grip | [5] Right cover |
| [2] Upper front cover | [6] Upper cover |
| [3] Compartment open switch | [7] Rear cover |
| [4] Front cover | |

1.2.2 Cross Section

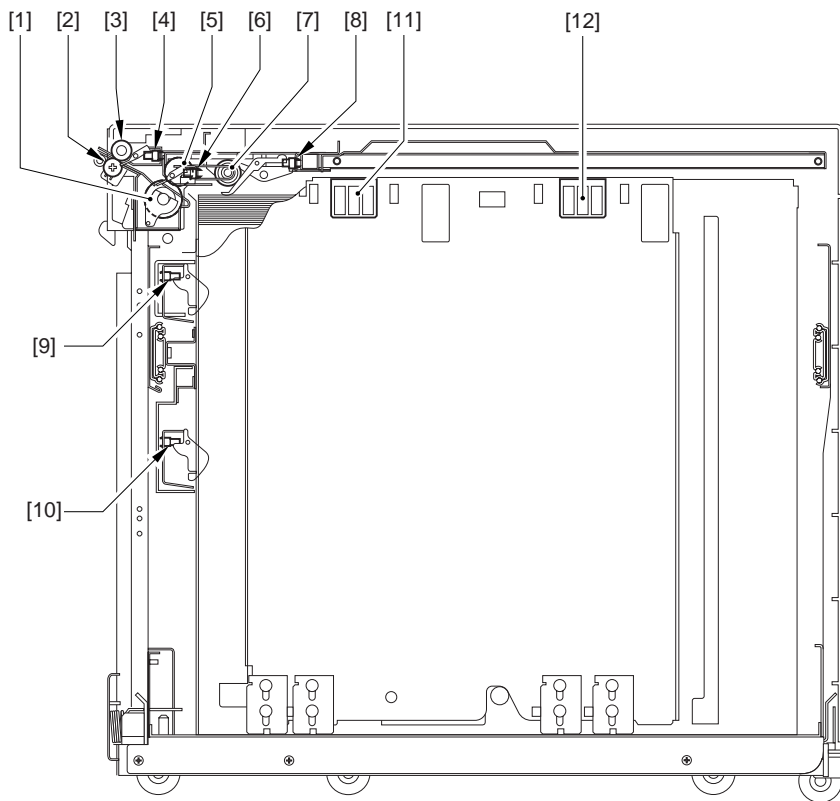

- | | |
|-----------------------------|---------------------------------|
| [1] Deck separation roller | [7] Deck pickup roller |
| [2] Deck feed roll | [8] Deck paper sensor |
| [3] Deck feed roller | [9] Deck supply position sensor |
| [4] Deck feed sensor | [10] Deck paper level sensor |
| [5] Deck pickup/feed roller | [11] Blow-out vent (warm air) |
| [6] Deck pickup sensor | [12] Blow-out vent (cool air) |

Chapter 2 Installation

Contents

2.1 Installation Procedure	2-1
2.1.1 Turning OFF the Host Machine	2-1
2.1.2 Installation Procedure	2-1
2.1.3 Affixing of Labels	2-9
2.2 Making Adjustments	2-10
2.2.1 Switching the Paper Size	2-10
2.3 Checking the Operation	2-10
2.3.1 Cable connection.....	2-10
2.3.2 Adjustment of side registration (image write-start position in main scanning direction).....	2-10

2.1 Installation Procedure

2.1.1 Turning OFF the Host Machine

- 1) Turn OFF the main power switch.
- 2) Check that the Control Panel display and the main power lamp are OFF, and then disconnect the power plug.

2.1.2 Installation Procedure

CAUTION:

In the Host Machine, when installing the Paper Deck, be sure to pay attention to the following points.
 -Install it after the Host Machine installation is completed.
 -Do not move the Host Machine when the Paper Deck is in installed condition, as it will cause damage.

<Preparation of the Host Machine>

- 1) Cut the cover area [3] of the Right Lower Cover 2 [1] and Right Lower Cover 3 [2] in the Host Machine with nipper, etc.

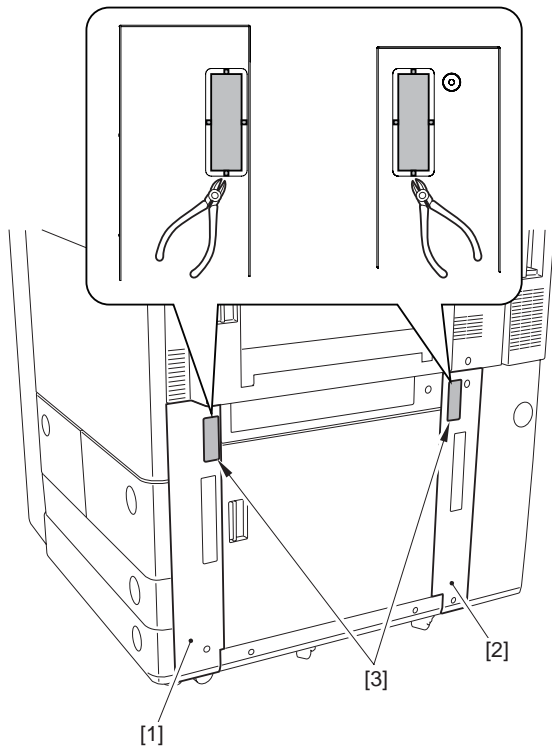

F-2-1

- 2) Install the Latch Plate (front side) [1] and Latch Plate (rear side)[2].
 - 4 screws (RS Tight; M4X8) [3]

CAUTION:

The positioning holes of the Latch Plate (front side) and the Latch Plate (rear side) have different shape. When installing, be sure to check the shape.
 Front side [4] : horizontally wide hole
 Backside [5] : vertically long hole

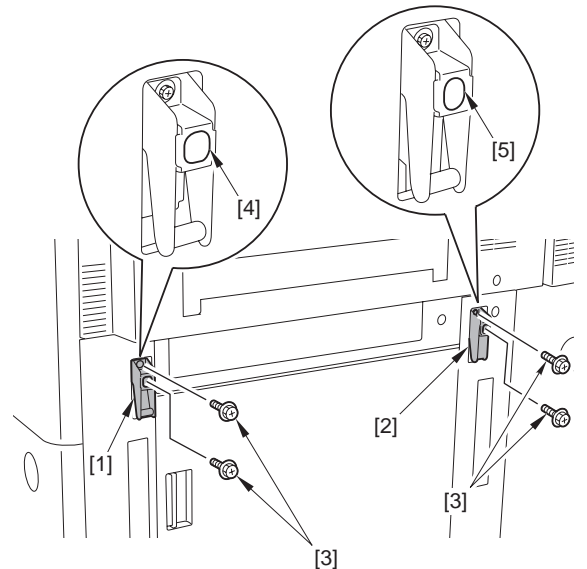

F-2-2

CAUTION:

When installing the Latch Plate (front side)[1], be sure that the position is in the center of the long hole[2].

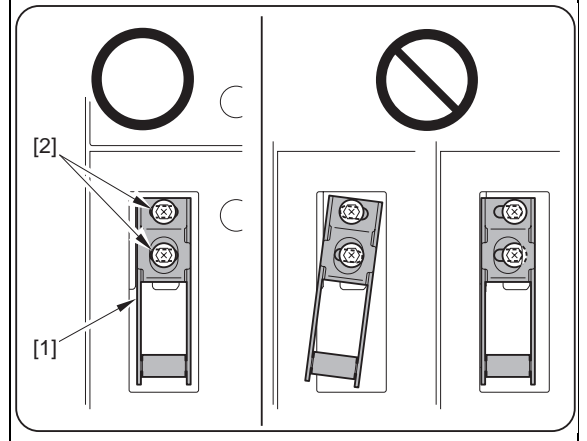

- 3) Open the Multi-purpose Tray Cover.
- 4) Insert the cut-off part [2] of the Inner Cover [1] with the slotted screwdriver etc., lift the cover and remove the protrusions [A] in 2 places.

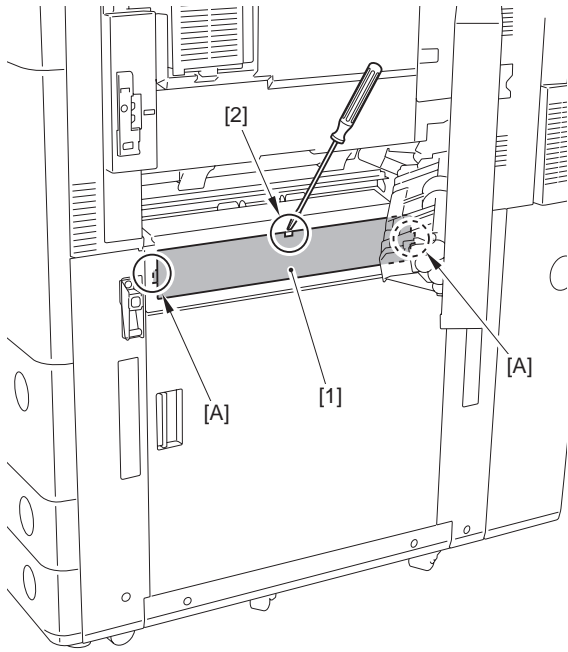

F-2-3

- 5) Close the Multi-purpose Tray Cover.
- 6) Remove the Right Lower Cover (middle) [1]. (The removed cover and screw will not be used anymore).
- 2 screws [2]

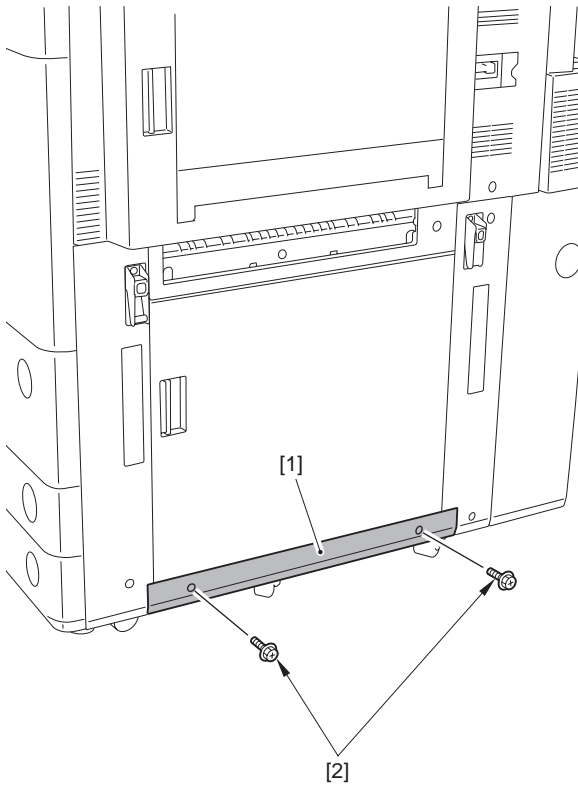

F-2-4

<Installation of the Equipment>

- 7) Lower the adjuster [1] of the base stay unit in 2 places to the position where the adjuster shaft [2] doesn't hit the plate [3].

MEMO:
When lowering the Adjuster Shaft [2], be sure to keep a space between the Adjuster [1] and the floor surface [4].

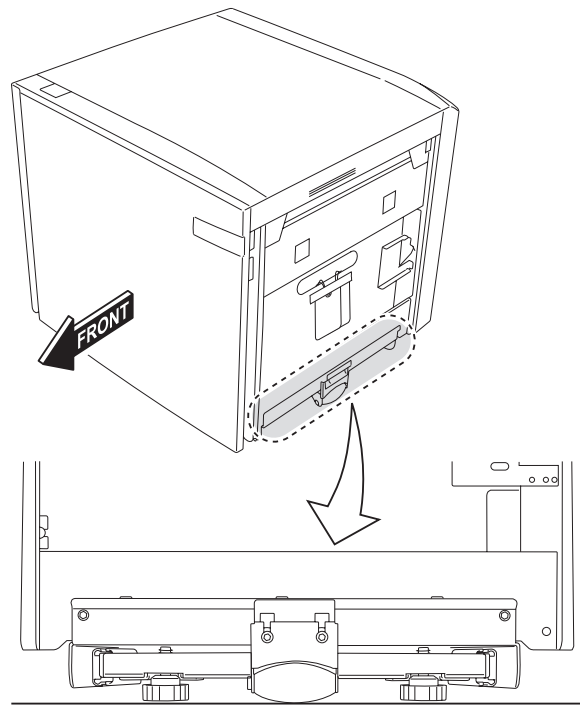

F-2-5

- 8) Release fixing of the Base Stay Unit, and slide the equipment.
- 1 Screw [1] (The removed screw will be used in step 9.)
- Spacer [2] (The removed spacer will not be used anymore)

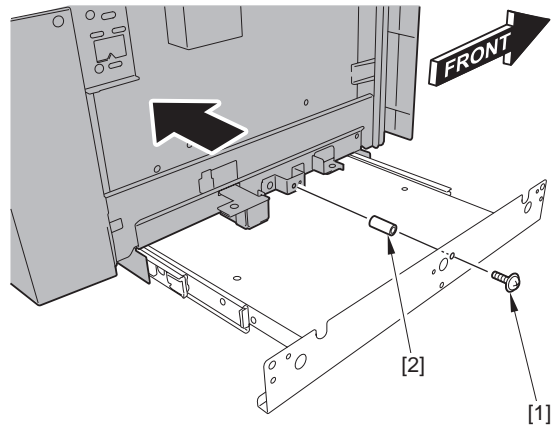

F-2-6

- 9) Install the screw [1] removed on the previous step 8) to the position on the below figure.

CAUTION:
When moving the Host Machine for instance during removal etc., it is necessary to secure the Base Stay Unit. Keep the screw [1] by installing it in the position as the below figure.

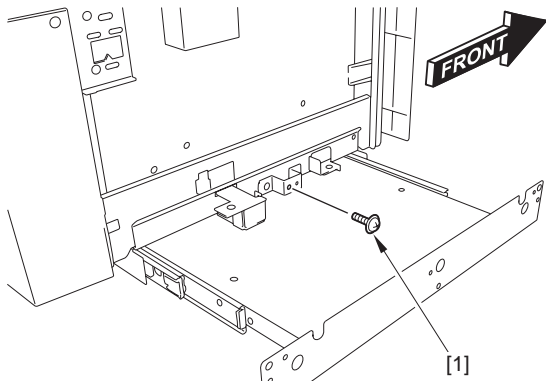

F-2-7

- 10) Attach the 2 bottom stay pin support plates [1] to the bottom stay unit.
- 2 screws (RS Tight;M4X8) [2]

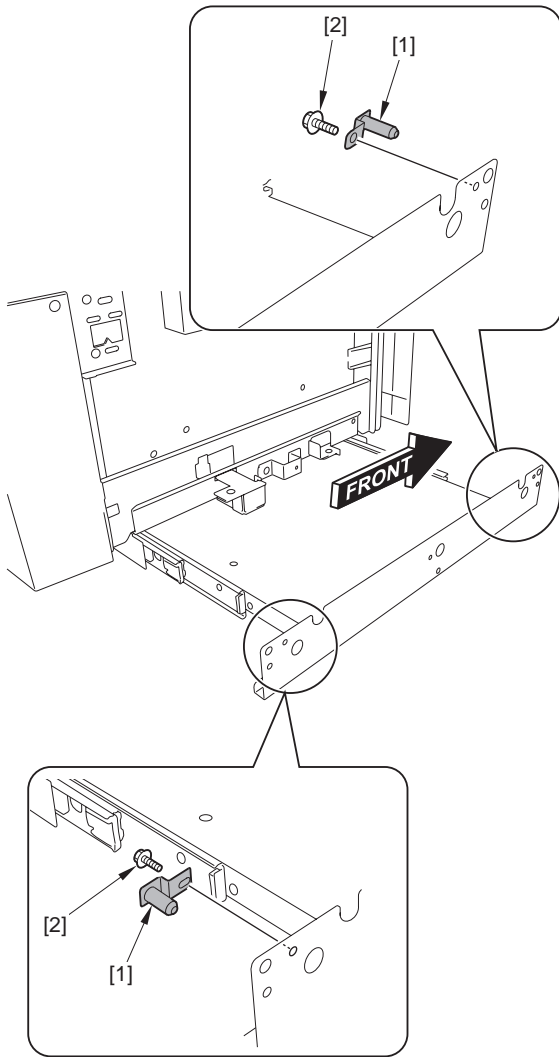

F-2-8

- 11) Insert and install the positioning pins [1] of the Base Stay Unit in 2 places in the hole [2] of the Host Machine in 2 places.
- 3 screws (RS tight;M4X8) [3]

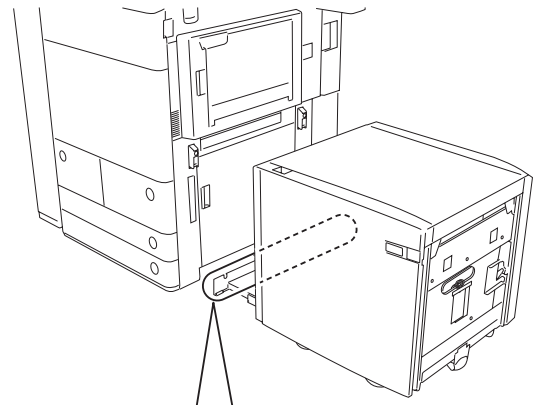

F-2-9

- 12) Remove the filament tape appeared the external of the paper deck.
13) Raise the Roller Pressure Release Bracket [1] to the [A] direction, and remove it to [B] direction.

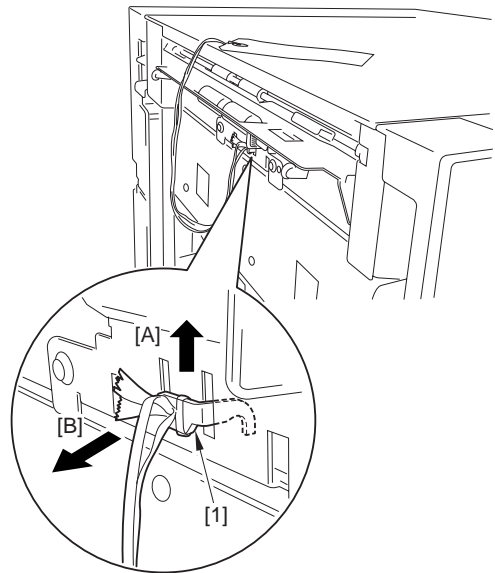

F-2-10

- 14) Install the equipment to the Host Machine.

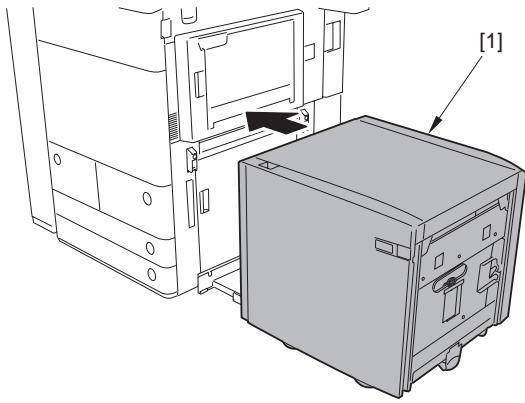

F-2-11

CAUTION:
 - If during installing, positioning pin [1] of the Host Machine backside can't be inserted into the hole [2] of the Latch Plate, loosen the screw of the Latch Plate [3] and adjust the positioning pin [1] to the position fit the Latch Plate hole [2]. And when tightening the loosened screw, make sure that the Latch Plate is not diagonally positioned.
 - When installing the Paper Deck to the Host Machine, be sure that the cables don't get caught between.

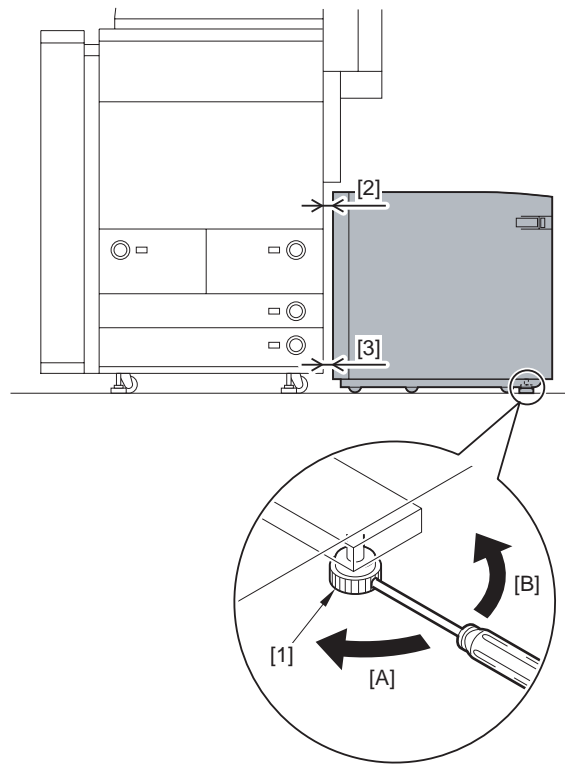

F-2-13

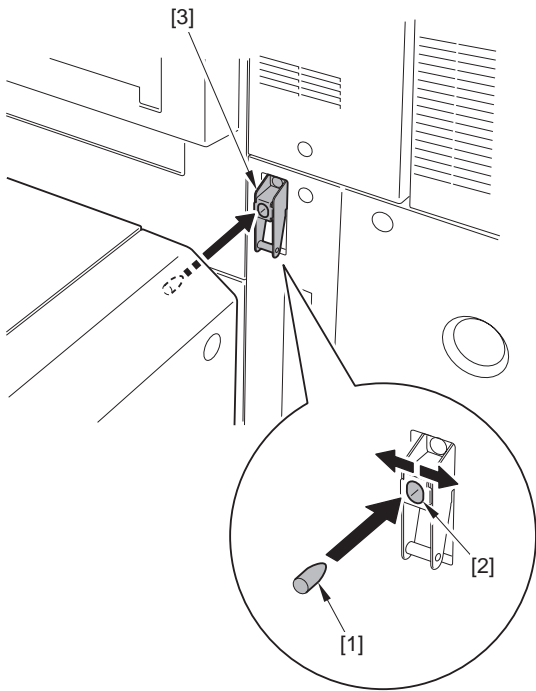

F-2-12

- 15) Insert the screwdriver in the adjuster [1] of the Base Stay Unit in 2 places, turn it, and adjust the gap between the equipment and the Host Machine (upper [2] and lower [3]) until they become parallel.
 - Rotate to [A] direction: the equipment will ascent
 - Rotate to [B] direction: the equipment will descent

⚠ The lower side space [3] should not be wider than the upper side space [2] because the connected paper deck may not be recognized by the host machine.
 - The lower side space [3] is done as well as the upper side space [2]. However, it narrows in the tolerance within 2mm.
 - Check on the space between the host machine and the paper deck when they are moved to a different location. If the lower side space has become wider than the upper side space, adjust the space so that the paper deck is in parallel with the host machine.

- 16) Pull the release button [1] in the right side, and release the equipment [2] from the Host Machine.

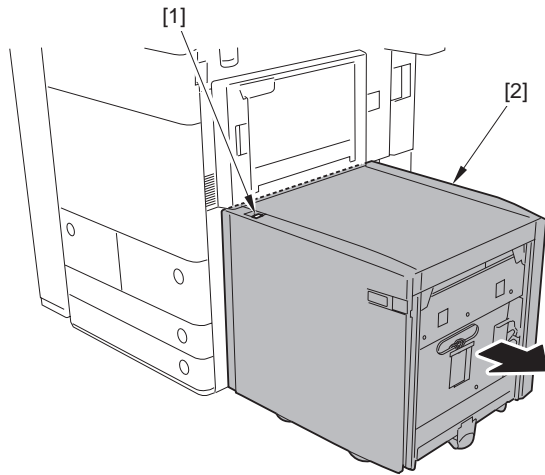

F-2-14

17) Lower the release lever [1] of the deck left side to the direction of the arrow.

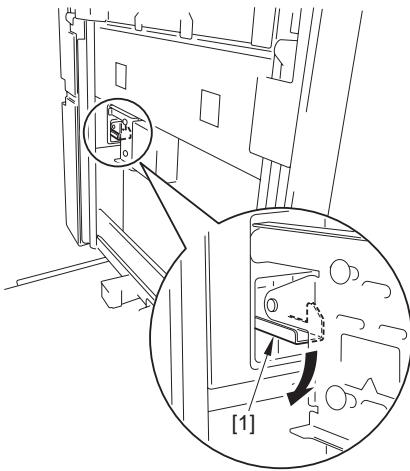

F-2-15

18) Use screwdriver, etc. to move the latch [1] in the direction of the arrow, and open the deck.

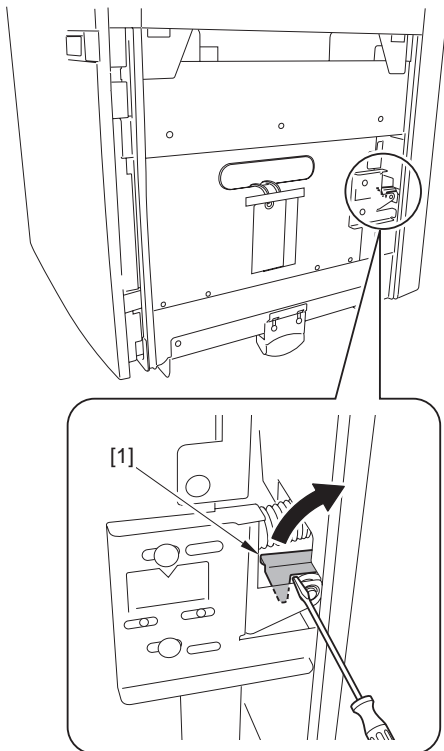

F-2-16

19) Remove the packing tapes [2] fixing the Shipping Tag [1].

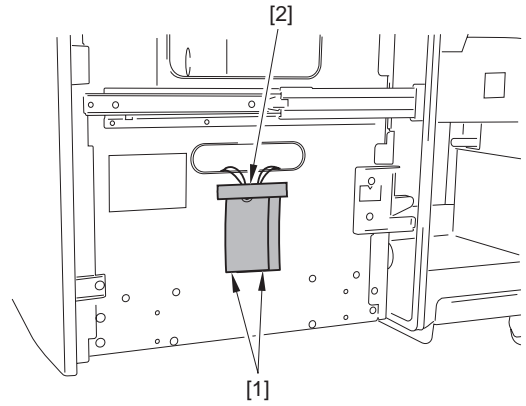

F-2-17

20) Remove the 2 screws [1], and pull out 2 fixing members [2] and tag [3] to the upper direction. (Removed screws will not be used anymore).

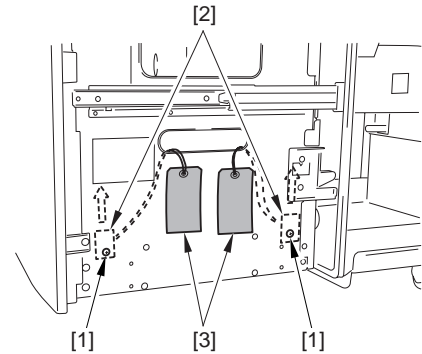

F-2-18

21) Remove the 4 screws [1], and pull out the 4 tags. (Removed screws will not be used anymore).

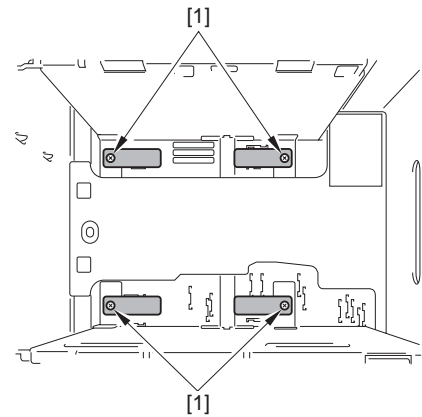

F-2-19

22) For rough indication when installing, remember the scale marked around the mounting screw of the Deck Front Cover.

23) Loosen the 4 screws [1], and remove the Deck Front Cover [2].

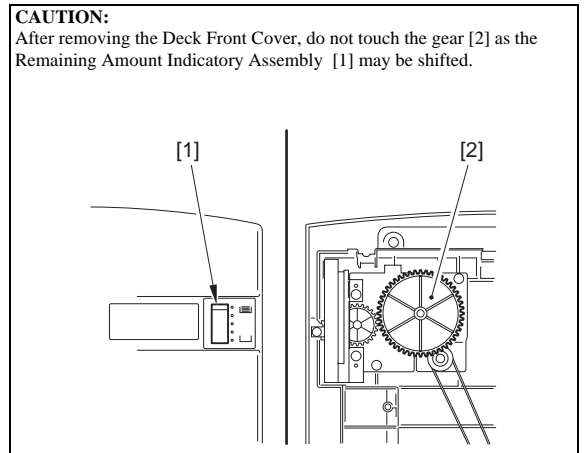

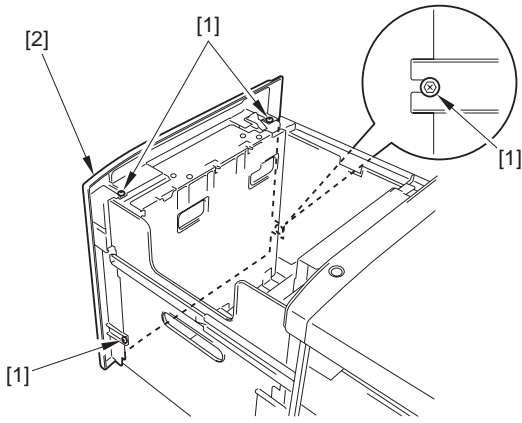

F-2-20

24) Loosen the 8 screws [2] of the wheel support plate [1] in the condition the deck is fully pulled out in the front direction.

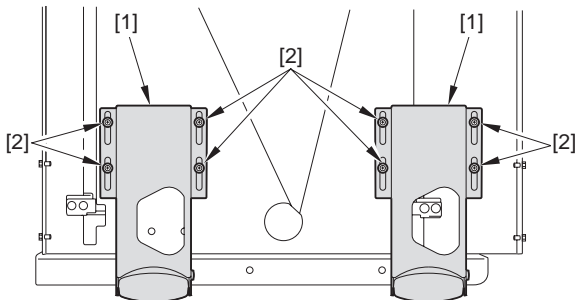

F-2-21

25) Adjust the wheel until its height [A] is 3 mm from the floor, and re-tighten the 8 screws [2].

MEMO:
The 3 mm scale marked [B] when the wheel is in the floor, will become rough indication of installing position when the Wheel Support Plate is lifted.

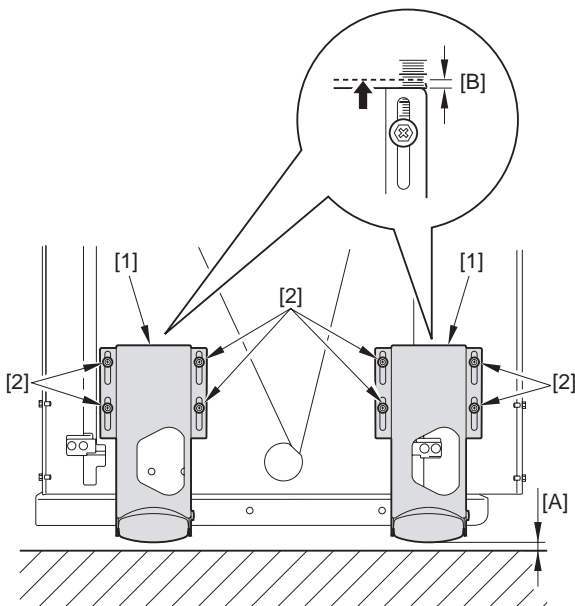

F-2-22

26) Loosen the 2 fixing screws [2] of the Wheel Support Plate [1] in the right side.

27) In the condition the deck is fully pulled out in the front direction, adjust the wheel until its height [A] is 3 mm from the floor, and re-tighten the 2 screws [2].

MEMO:
The 3 mm scale (1 scale = 2 mm interval) marked [B] when the wheel is in the floor, will become the rough indication of installing position to lift the Wheel Support Plate [1].

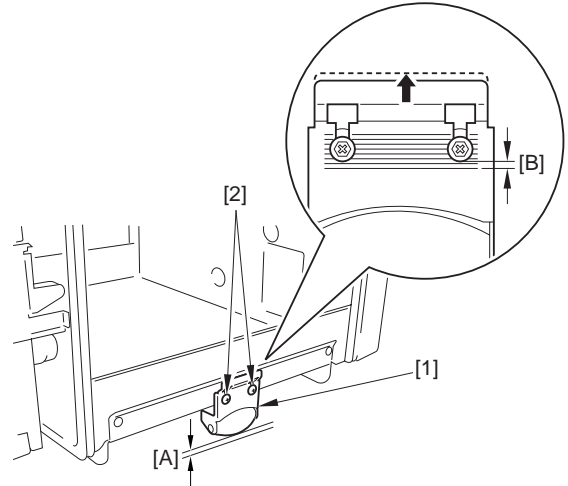

F-2-23

28) Set-in the gear [1] of the Deck Front Cover after adjusting it to the Coupling [2], and install it in the original position. (Tighten it with the screw that loosened in step 23).

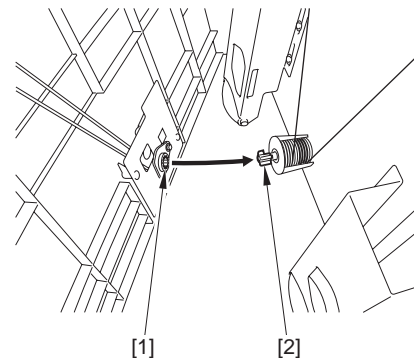

F-2-24

29) Close the deck, and make sure that the gap [3] between the Deck Front Cover [1] and Front Upper Cover [2] is 3 mm, give or take 1 mm.

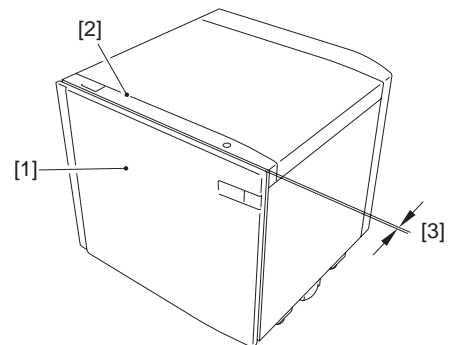

F-2-25

MEMO:
If it is not in the 3 mm range, give or take 1 mm, open the Deck, and loosen the 4 screws [2] of the Deck Front Cover [1], and install it so that the gap is 3 mm, take or give 1 mm.

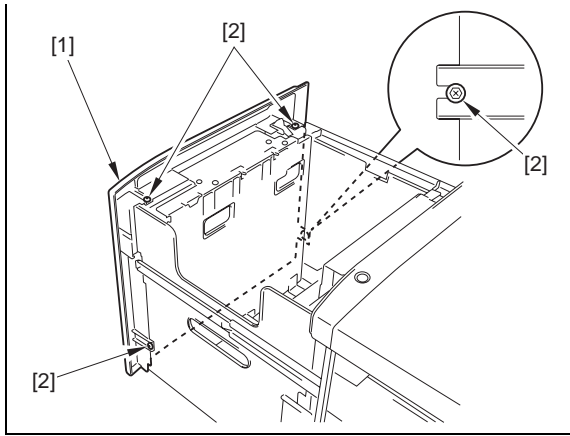

- 30) Open the deck.
- 31) Tighten the Rear Edge Guide Plate [1] with coin screw [2] in the position of initial setting paper size (A3 or 11x17).

MEMO:
 1. Depends on the user's request, to change the paper size, be sure to execute "Setting Paper Size".
 2. Spacer adhered in the inner side of the Rear Edge Guide Plate is for user adjustment. If it is not used, install it to the Host Machine in adhered condition.

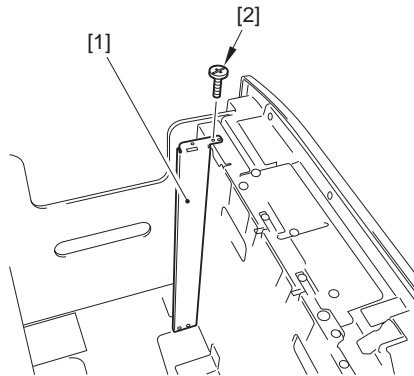

F-2-26

- 32) Put the Base Plate on the Lifter Plate.
 - When A4R, LTRR, LGL, B4, B5 paper is used, use the base plate (small) [1].
 - When the other paper that the ones written above is used, use the base plate (large) [2] on the Lifter Plate.

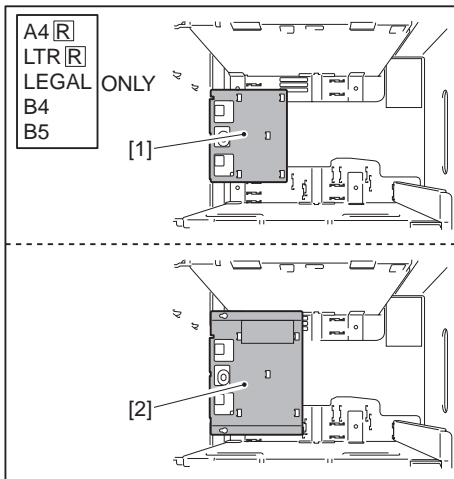

F-2-27

- 33) Pull out the Base Sheet [1] in the paper size from the Base Set, put it on the Lifter Plate.

CAUTION:
 Be sure that the Base Sheet [1] is not placed on top of the Separation Sheet [2].

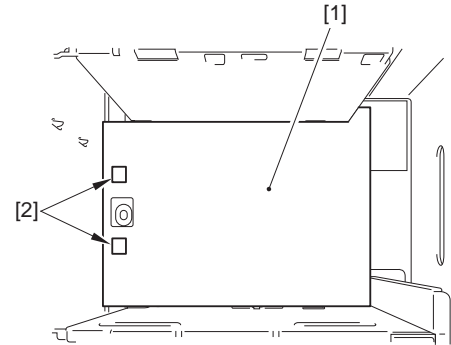

F-2-28

- 34) Loosen the screw [1] in the left side surface.

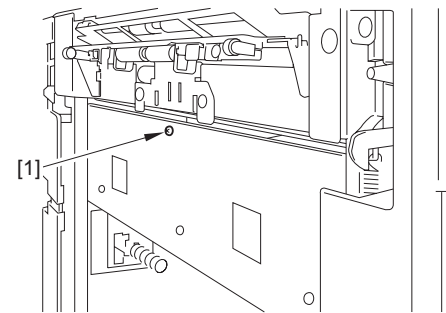

F-2-29

- 35) Insert the protrusion part [1] in 2 places in the holes of the deck, hook the Deck Left Cover [2] in the loosened screw, and tighten the screw [3].

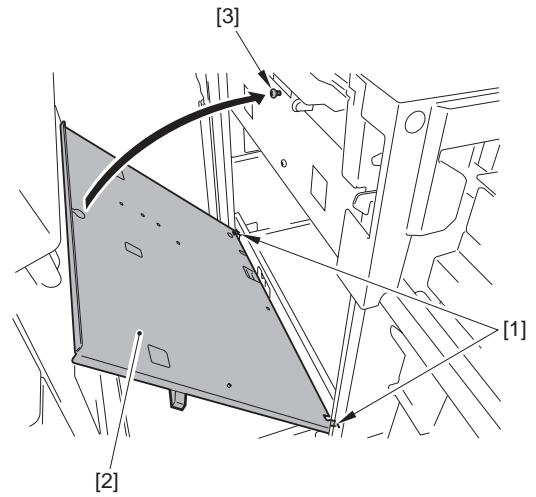

F-2-30

- 36) Hook the base plate [1] that wasn't used in the step 32) on the 2 screw [2] of the Deck Left Cover.
 - If it is Base Plate (large) [1], hook it in the 2 screws [2] of the Deck Left Cover.

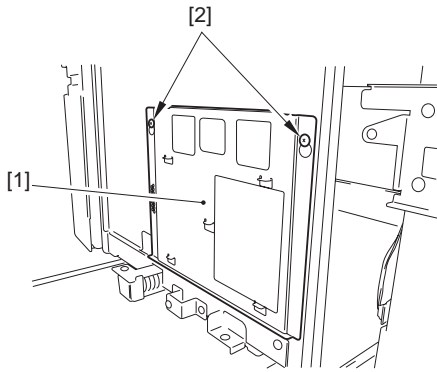

F-2-31

- If it is Base Plate (small) [1], hook it in the 1 screw [2] of the Deck Left Cover.

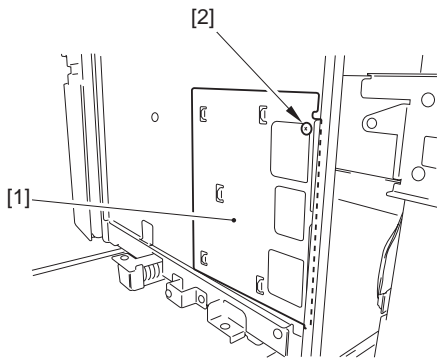

F-2-32

37) Install the Rear Edge Retaining Unit [1].

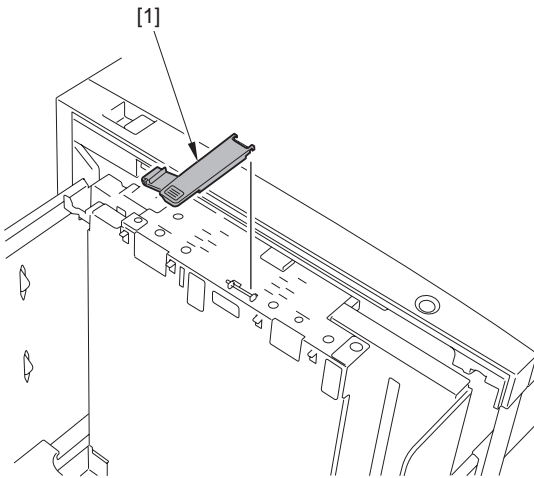

F-2-33

38) Insert the projection part [2] of the Deck Right Cover [1] in 2 places in the Paper Deck, and install the cover.
- 3 screws (RS tight;M4X8) [3]

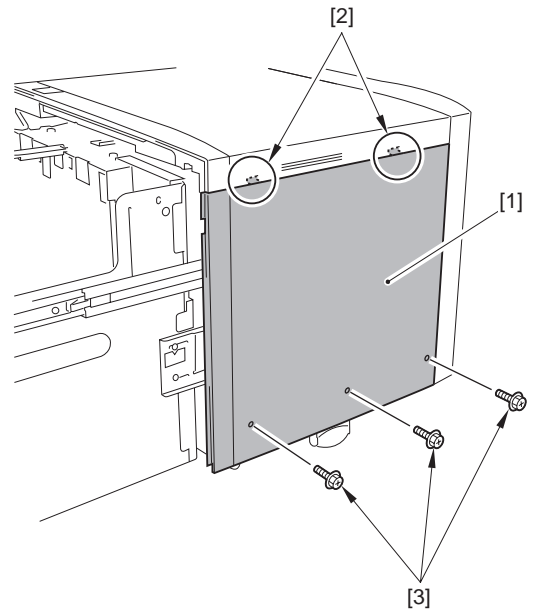

F-2-34

39) Close the Deck.
40) Adhere the "Points to Note for Host Machine connection" label [1] in the Right Lower Door of the Host Machine.

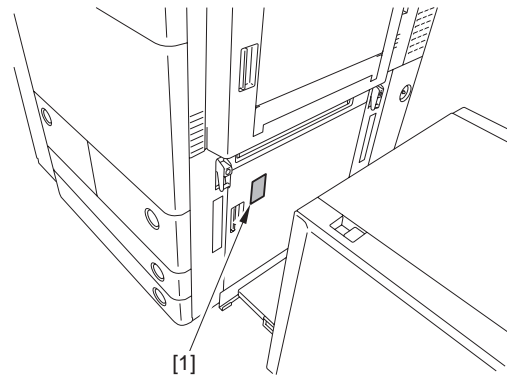

F-2-35

41) Install the equipment in the Host Machine.

CAUTION:
When installing the Paper Deck to the Host Machine, be sure that the cables don't get caught between.

42) Remove the connector cover [1], and connect the connector [2] of the equipment to the Host Machine.

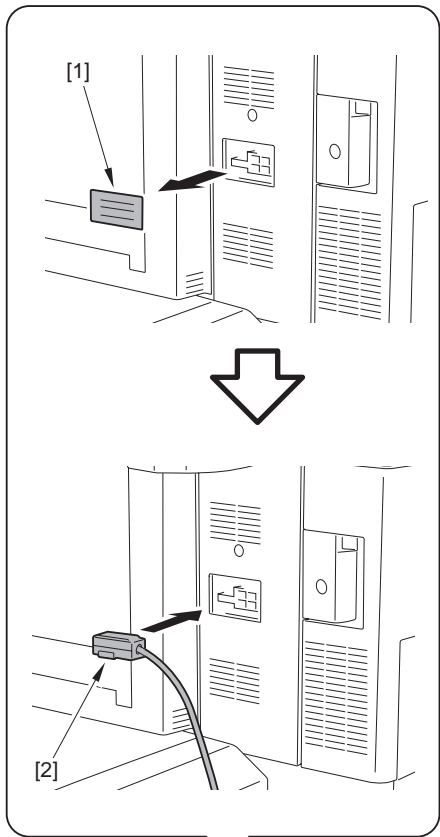

F-2-36

43) Peel off the cover seal [1], install the wire saddle [2], and tighten the cable [3] of the equipment. (The removed cover seal will not be used anymore).

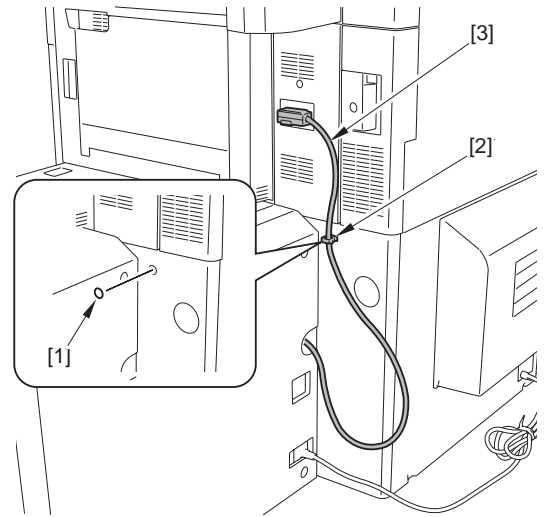

F-2-37

2.1.3 Affixing of Labels

1) Check the user's request, and affix the paper size label [2] on the size indication plate [1].

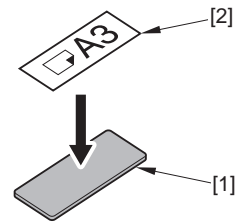

F-2-38

2) Attach the size indication plate [1] to the deck front cover.

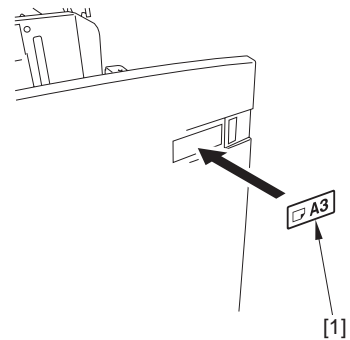

F-2-39

3) Affix the open/close switch label [1].

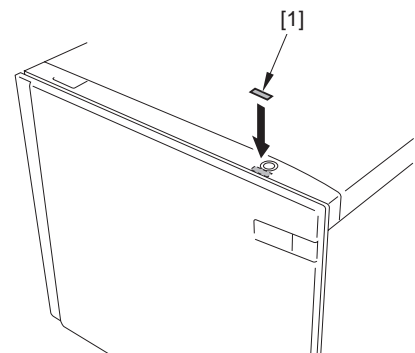

F-2-40

4) Open the deck.
5) Affix the hand trapping warning label [1].

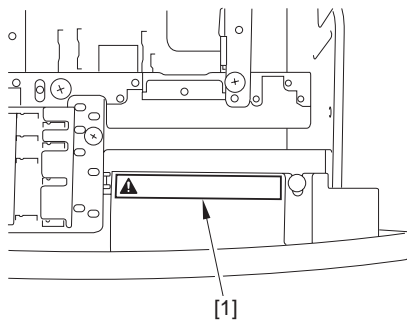

F-2-41

- 6) If the language is not appropriate for those size switching warning labels affixed on shipping, affix the correct size switching warning label [1] on the position [A].

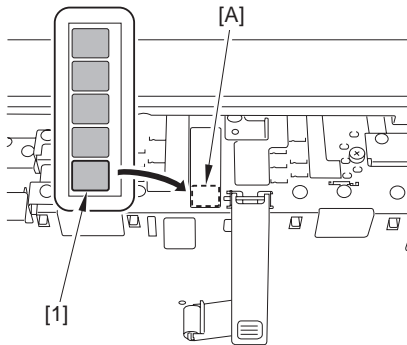

F-2-42

- 7) If the language is not appropriate for those obstacle warning labels affixed on shipping, affix the correct obstacle warning label [1] on the position [A].

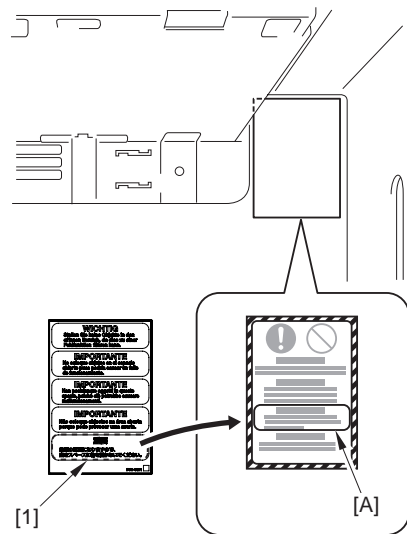

F-2-43

- 8) Close the deck.

2.2 Making Adjustments

2.2.1 Switching the Paper Size

- 1) Open the deck.
- 2) Pull out the base sheet and base plate.
- 3) Remove the 5 fixing screws [1] of the guide plate, and fit the fixing position of both the front/rear guide plate and the rear edge guide plate according to the paper size to tighten the removed 5 screws.

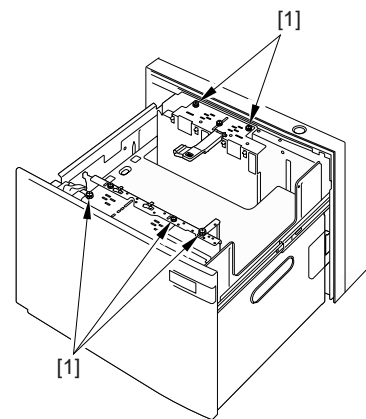

F-2-44

- 4) Attach the base plate and the base sheet according to the paper size.
- 5) Load a paper and close the deck.
- 6) Connect the power plugs of the host machine and also of the other devices to enable 'ON' the power switch.
- 7) Set the paper size.
 - SERVICE MODE > COPIER > OPTION > ACC > DK-P

2.3 Checking the Operation

2.3.1 Cable connection

- 1) Insert power plug of the Host Machine and each device to consent.
- 2) Switch ON the power of the Host Machine.
- 3) In the high humidity environment, switch ON the heater in the backside of the Paper Deck.

MEMO:

Memo: High humidity determination is, if the value of amount of absolute moisture in the service mode host machine is 10g or more.
COPIER > DISPLAY > ANALOG > ABS-HUM

- 4) Install the Paper Deck in the Host Machine.

2.3.2 Adjustment of side registration (image write-start position in main scanning direction)

- 1) Set the test chart (CANON CA-A TESTSHEET) in the copyboard glass.
- 2) Do copy from the equipment, and make sure that left margin L1 of the image is 2.5 mm, give or take 1.5 mm. If it is out of the standard, do adjustment by the following steps.

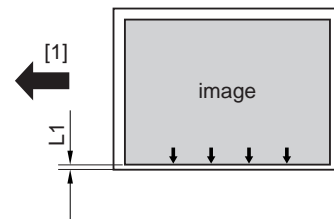

F-2-45

[1] Feed direction

<In the Case of 320 mm or Smaller Paper Size>

Execute step 3 and 4.

- 3) Adjust the side registration (image write start position in the horizontal scanning position).

- COPIER > ADJUST > FEED-ADJ > ADJ-DK

- 4) Adjust the value according to the result of image in test chart.

<In the Case of 321 mm to 330.2 mm Paper Size>

Execute step 5 to 11.

- 5) Open the deck.
- 6) Loosen the 2 screws [2] of the Latch Claw Adjustment Plate [1] in the right side of the deck.
- 7) Adjust the Latch Claw Adjustment Plate [1] by moving it front and back. (1 scale = 1mm interval).
 - If you want to move the paper position to backside, move the Latch Claw Adjustment Plate to front side [A].
 - If you want to move the paper position to front side, move the Latch Claw Adjustment Plate to backside [B].

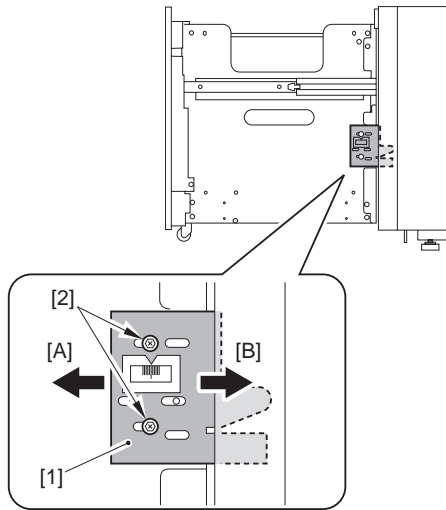

F-2-46

- 8) Tighten the 2 screws of the Latch Claw Adjustment Plate.
- 9) Adjust the Latch Claw Adjustment Plate in the left side also in the same way.
- 10) Close the deck.
- 11) Make a copy from the equipment and check that the left margin is within 2.5 ± 1.5 mm on the image. If it is not within the standard, go back to step 5) and make an adjustment again.

CAUTION:

In the case of shifting the latch claw adjustment plate, be sure to make adjustment for the gap of the deck front cover by referring to the step 29) in the Installation Procedure.

Chapter 3 Functions

Contents

3.1 Basic Construction	3-1
3.1.1 Functional Construction.....	3-1
3.1.2 Overview of the Electrical Circuitry.....	3-1
3.2 Pick-Up/Feed System.....	3-2
3.2.1 Overview.....	3-2
3.2.2 Pickup Operation	3-2
3.3 Paper Detection	3-3
3.3.1 Paper Level Detection.....	3-3
3.3.2 Detecting the Presence/Absence of Paper.....	3-4
3.3.3 Switching the Paper Size	3-4
3.4 Deck Lifter	3-4
3.4.1 Overview.....	3-4
3.4.2 Controlling the Lifter	3-5
3.4.3 Indicating the Level of Paper on the Deck Front Cover	3-5
3.5 Opening /Closing the Compartment	3-6
3.5.1 Opening and Closing of the Compartment	3-6
3.5.2 Sequence of Operations (opening/closing).....	3-6
3.6 Air Assist Control	3-7
3.6.1 Overview.....	3-7
3.6.2 Controlling the Air Separation Mechanism	3-7
3.6.3 Swing Movement	3-8
3.7 Detecting Jams	3-9
3.7.1 Overview.....	3-9
3.7.2 Types of Jams	3-9
3.7.3 Sequence of Operations Used to Detect Jams.....	3-10
3.8 Power Supply	3-11
3.8.1 Power Supply	3-11
3.8.2 Protection Function.....	3-11
3.9 Fan.....	3-12
3.9.1 Overview.....	3-12

3.1 Basic Construction

3.1.1 Functional Construction

The machine's functions may be grouped into the following 3 blocks: lifter drive system, pickup drive system, deck control system.

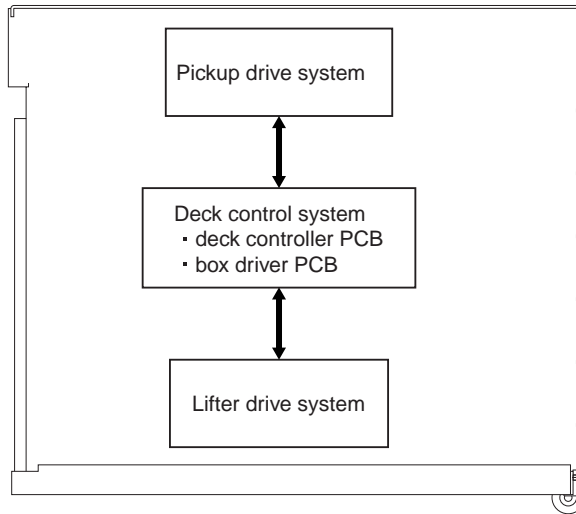

F-3-1

3.1.2 Overview of the Electrical Circuitry

The machine's electrical mechanisms are controlled by the deck controller PCB and the box driver PCB.

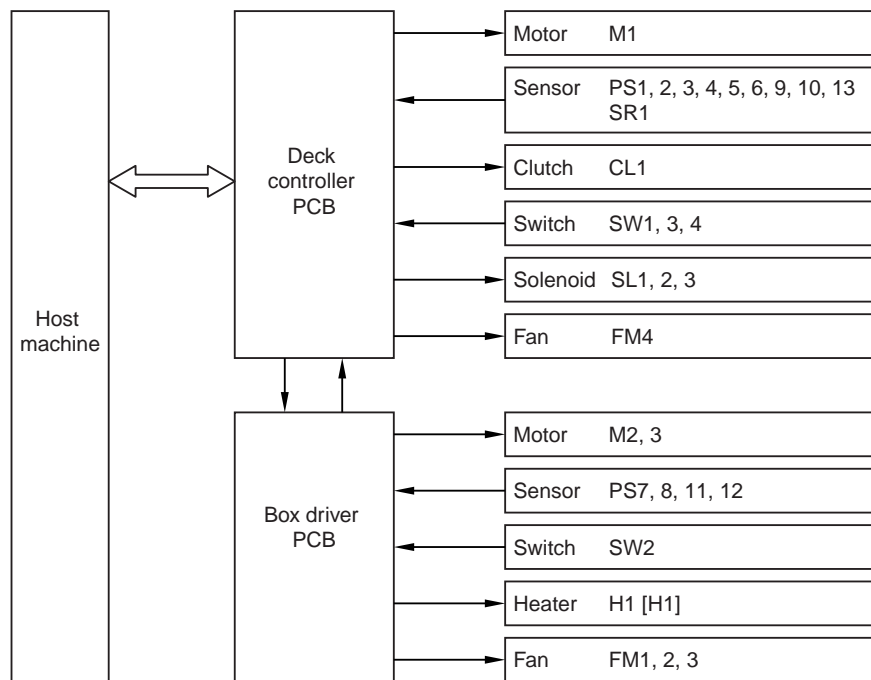

F-3-2
T-3-1

Notation	Name	Notation	Name	Notation	Name
PS1	deck pickup sensor	SR1	environment sensor	FM1	warming fan
PS2	deck paper sensor	M1	deck pickup motor	FM2	cooling fan
PS3	deck lifter upper limit sensor	M2	deck lifter motor	FM3	additional fan
PS4	deck lifter position sensor	M3	swing motor	FM4	motor cooling fan
PS5	deck connection sensor	CL1	deck pickup clutch	H1	air heater (230 V)
PS6	deck pull-out sensor	SL1	deck pickup roller release solenoid	[H1]	air heater (120 V)
PS7	deck supply position sensor	SL2	compartment open right solenoid	H2/H3	cassette heater (230 V)
PS8	deck paper level sensor	SL3	compartment open left solenoid	[H2/H3]	cassette heater (100 V)
PS9	compartment right open sensor	SW1	lifter motor safety switch		
PS10	compartment left open sensor	SW2	deck lifter lower limit detecting switch		
PS11	swing sensor	SW3	compartment open switch		
PS12	paper level sensor	SW4	fan safety switch		
PS13	obstacle sensor	SW5	cassette heater switch		

3.2 Pick-Up/Feed System

3.2.1 Overview

The paper deposited in the compartment is picked up and moved to the host machine by the drive of the deck pickup motor (M1), and the movement of the paper is monitored by the deck pickup sensor (PS1) and the deck pull-out sensor (PS6) mounted in the paper path.

3.2.2 Pickup Operation

The paper deposited in the compartment is held up by the work of the lifter, and is kept to a specific level.

When the Start key on the host machine is pressed, and the deck pickup clutch (CL1) goes on in response, the drive of the deck pickup motor (M1) starts to rotate the pickup roller to pick up paper. At this time, the deck pickup/feed roller and the deck separation roller operate to make sure that only a single sheet of paper is picked up and moved. Thereafter, when the deck pickup sensor (PS1) detects paper, the deck pickup roller release solenoid (SL1) goes on to move the deck pickup roller away from the stack of paper.

The deck feed roller starts to rotate when the deck pickup/feed motor goes on. After pickup, the paper is moved as far as the registration roller of the host machine.

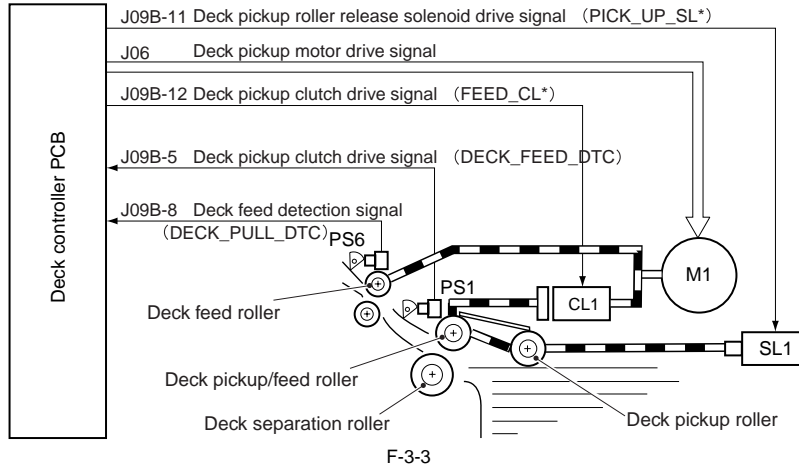

Sequence of Pickup Operations (from deck; A, 2 sheets, continuous)

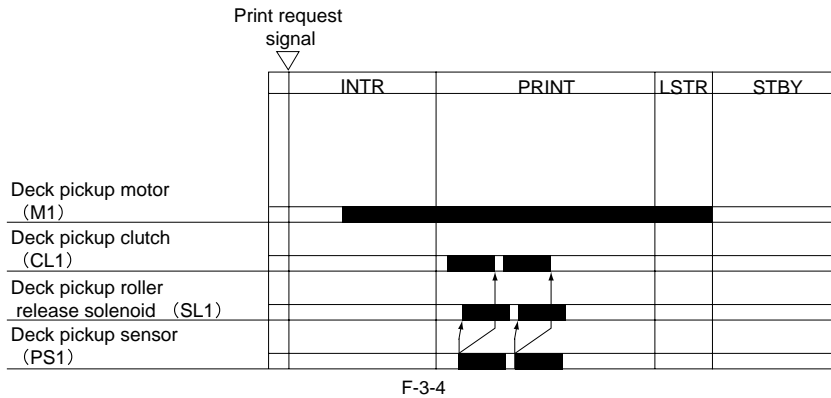

3.3 Paper Detection

3.3.1 Paper Level Detection

Paper level is detected by the following sensors. Detecting description is displayed on the Control Panel of the connecting device.

- Deck paper sensor (PS2)
- Deck supply position sensor (PS7)
- Deck paper level sensor (PS8)

T-3-2

Paper Level	PS2	PS7	PS8	1: ON (light-blocking) 0: OFF (Transmission)	
				Control Panel Screen Display	
100% to 50% (approx.)	1	1	1		
50% to 10% (approx.)	1	1	0		
10% or less (approx.)	1	0	0		
Out of paper	0	0	0		

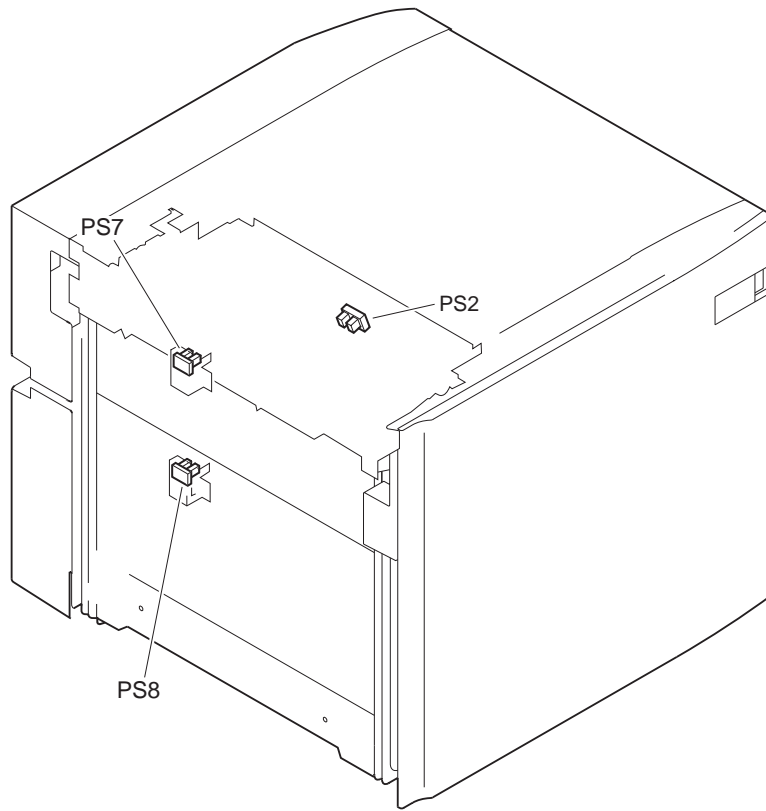

F-3-5

3.3.2 Detecting the Presence/Absence of Paper

The presence/absence of paper inside the compartment is checked by the deck paper sensor (PS2).

When the paper runs out and the paper detecting lever of the pickup roller assembly moves past the deck paper sensor as a result, the host machine indicates the absence of paper on its control panel.

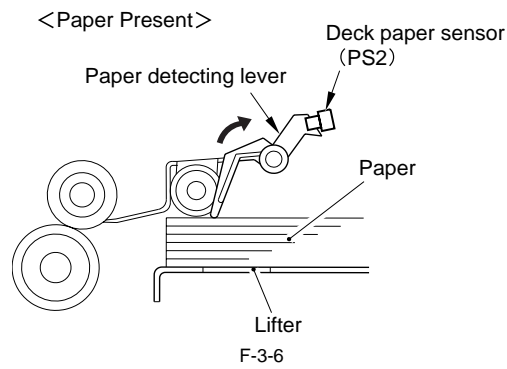

<Paper Absent>

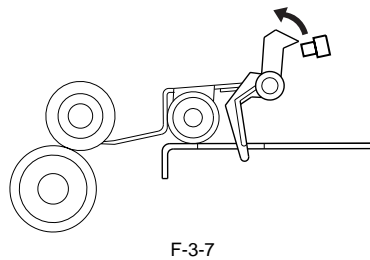

3.3.3 Switching the Paper Size

To change the paper size for the machine, move the guide plate inside the compartment to suit the paper size, and enter the appropriate paper size in user mode.

3.4 Deck Lifter

3.4.1 Overview

The machine's lifter is connected to a reel by means of a cable, and is driven by the deck lifter motor (M2). The machine changes the direction of motor rotation to move up or down the lifter.

3.4.2 Controlling the Lifter

Moving Up the Lifter

The lifter starts to move up when the lifter motor safety switch (SW1) and the compartment left/right open sensor (PS10, PS9) detects that the compartment has been set in place.

The lifter then stops when the deck lifter position sensor (PS4) detects the top surface of the stack of paper placed on the lifter.

The deck lifter upper limit sensor (PS3) is used to prevent damage otherwise caused by the failure of the lifter to stop after the sensor lever blocks the deck lifter position sensor.

The machine is also equipped with a protective mechanism by means of an obstacle sensor (PS13) used to prevent damage to the lifter cable and resin gears lest a foreign object inside the compartment should hit the ceiling before the deck lifter position sensor detects the top surface of the stack of paper.

Moving Down the Lifter

The lifter starts to move down when the compartment open switch (SW3) is pushed, and keeps moving down until the lifter moves past the sensor lever of the deck supply position sensor (PS7), i.e., at the falling edge of the sensor signal.

When paper is supplied, the paper will push the lever of the deck supply position sensor, and the lifter keeps moving down until the paper moves past the sensor lever.

The machine repeats moving down the lifter unit when the deck lifter lower limit detecting switch (SW2) is pressed (i.e., maximum paper supply position) each time paper is added.

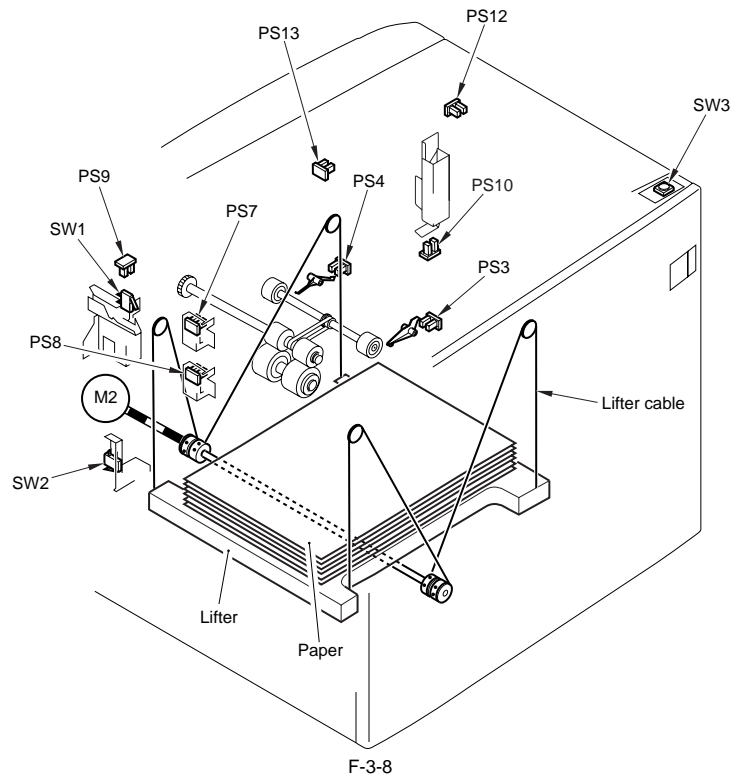

F-3-8

3.4.3 Indicating the Level of Paper on the Deck Front Cover

The drive of the deck lifter motor (M2) is received by the coupling, and then is transmitted to the rack by means of a drive belt. The rack is fitted with a black belt that moves behind the opening in the deck front cover in keeping with the movement of the rack.

When paper starts to run out and, as a result, the lifter moves up to the pickup position, the area of the black belt behind the opening will gradually increase, thereby indicating the decreases in the level of paper (by the area of white).

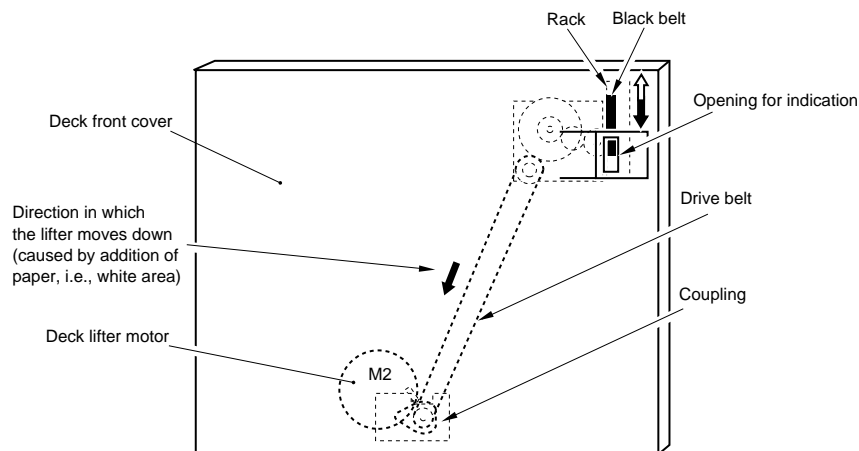

F-3-9

3.5 Opening /Closing the Compartment

3.5.1 Opening and Closing of the Compartment

When the compartment open switch (SW3) is pushed, the deck lifter motor (M2) starts to rotate to cause the lifter to move down. When 1 sec passes thereafter, the compartment open solenoid (left/right) (SL3, SL2) goes on to release the lock of the compartment. When the lock is released, the force of the spring causes the compartment to move forward by several centimeters.

The lock of the compartment is released a moment later to prevent the paper from becoming trapped by a guide or the like, possibly occurring if the compartment was let to open before the paper has dropped.

The compartment closes when it is manually pushed against the machine, causing the compartment left/right open sensor (PS10, PS9) to detect the light-blocking plate of the compartment and, thus, causing the lifer to move up as far as the point of pickup.

The compartment open indicator (LED1) on the open switch PCB flashes while the compartment is being opened/closed, and remains on as long as the compartment remains open.

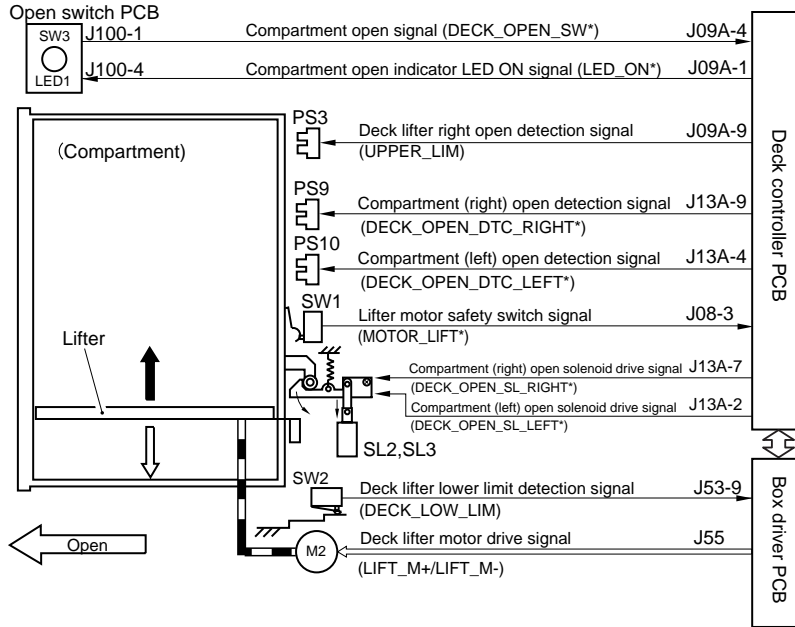

F-3-10

3.5.2 Sequence of Operations (opening/closing)

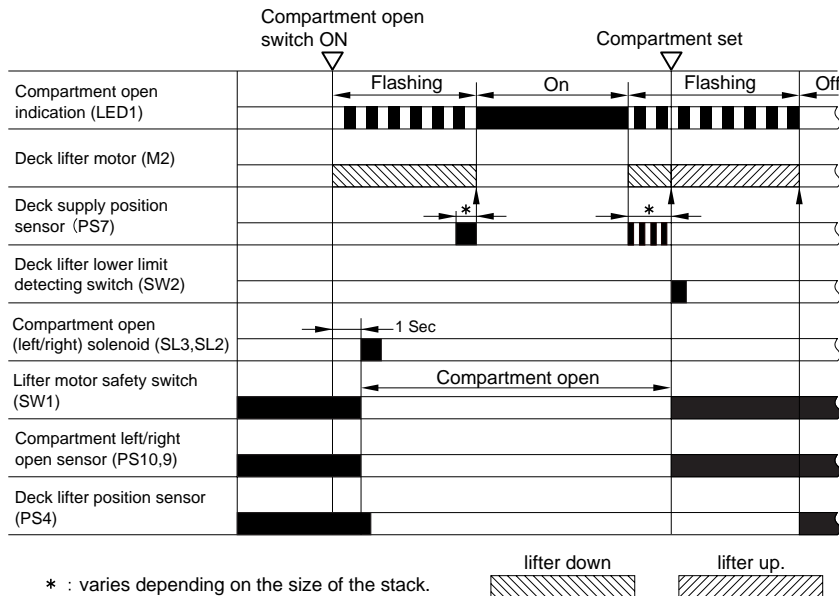

F-3-11

3.6 Air Assist Control

3.6.1 Overview

To facilitate separation of coated paper, the machine executes air-assisted control. The air heater (H1) and the fans (FM1, FM2) are combined to blow air against the paper so that the paper is shifted slightly to lose attraction, ultimately preventing double-feeding. The air-assisted control has made possible the use of coated paper, which so far resisted smooth movement inside the machine. The additional fan (FM3) of the machine, further, helps shift coated paper.

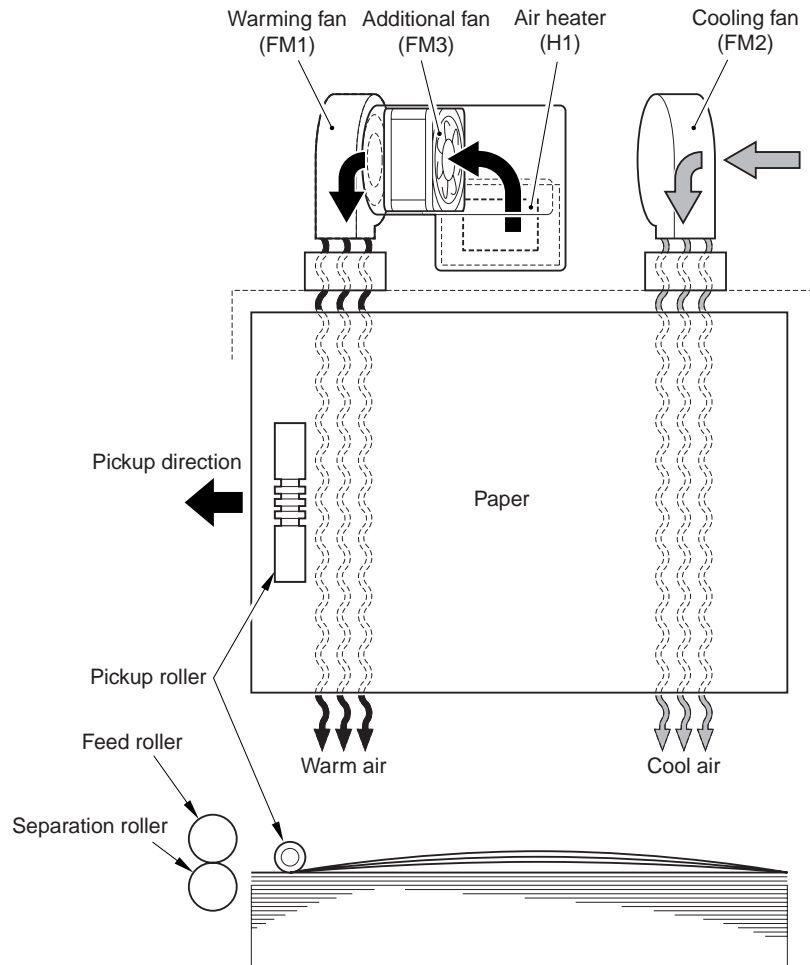

F-3-12

3.6.2 Controlling the Air Separation Mechanism

The air-assisted control mechanism is turned on by the DC controller PCB of the host machine and by way of the deck controller PCB. The air-assisted mechanism consists of the following control items:

T-3-3

Paper type	Warming fan (FM1)	Cooling fan (FM2)	Additional fan (FM3)	Air heater (H1)
Non coated paper (150g/m ² or less)	OFF	OFF	OFF	OFF
Non coated paper (151g/m ² or more)	ON *1	ON *1	OFF	OFF
Coated paper	ON	ON	ON *2	ON *3
Transparency	ON (27 V)	ON (27 V)	OFF	OFF
Texture paper	ON	ON	OFF	OFF
Labels	ON	ON	OFF	OFF
4 on 1 postcard	OFF	OFF	OFF	OFF

*1: Switches the OFF/12V/27V of fan according to the detected temperature&humidity of Environment Sensor (SR1).

*2: Switches the ON/OFF of fan according to the detected temperature&humidity of Environment Sensor (SR1).

*3: Switches the control temperature (60 deg C/90 deg C/OFF) of Air Heater according to the detected temperature&humidity of Environment Sensor (SR1).

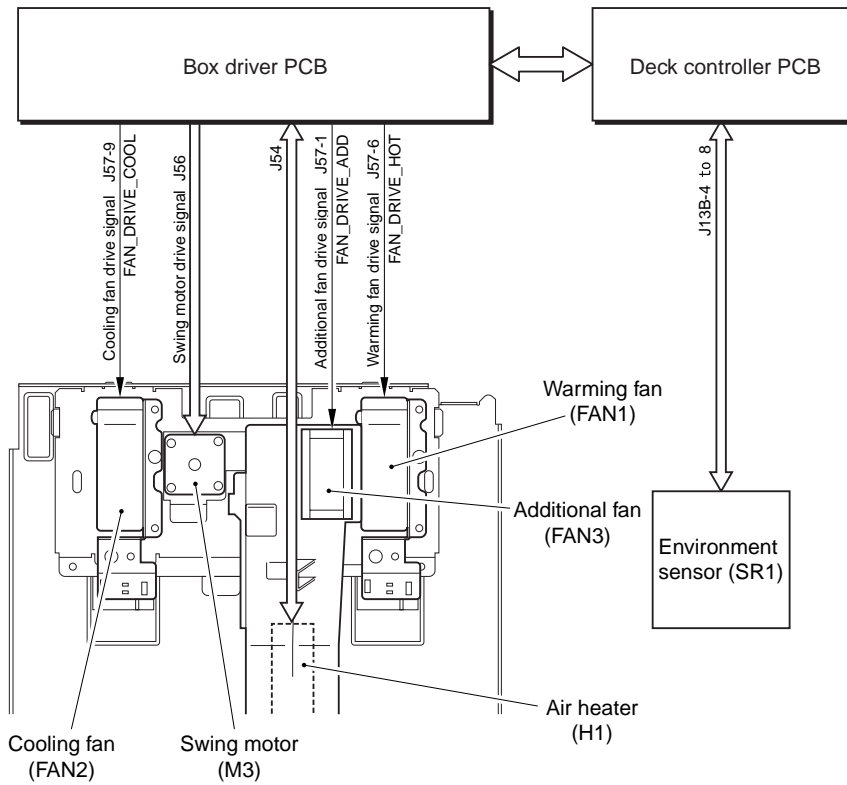

F-3-13

3.6.3 Swing Movement

The machine executes swing operation the same time as it blows air against paper to prompting separation of coated paper. The machine drives the swing motor (M3) to move up and down the shutter so that the air is directed to the paper from above and below, thereby vibrating the paper so that it will separate more easily. While the machine swings the shutter, it makes sure of the swing sensor (PS11) to check for an error.

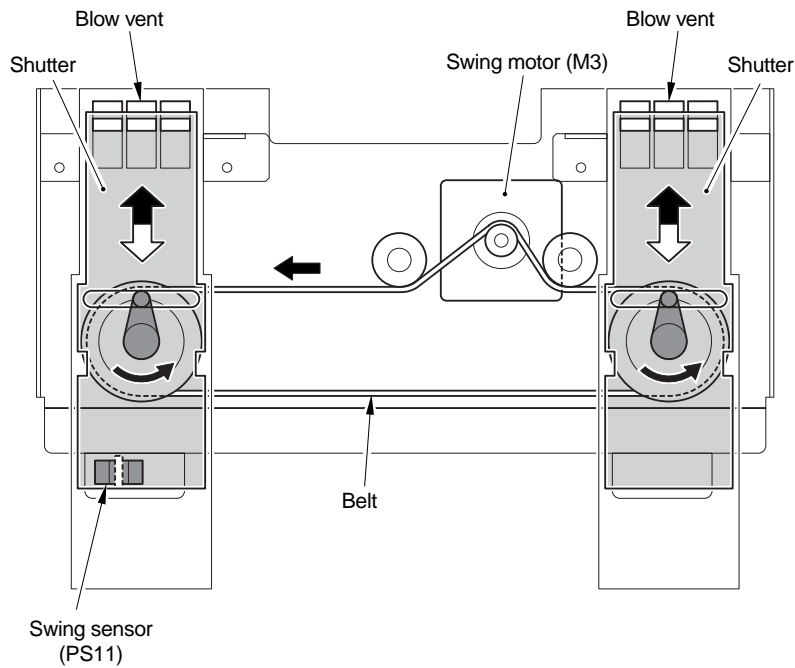

F-3-14

3.7 Detecting Jams

3.7.1 Overview

The machine uses the following 2 sensors to make sure that paper moves smoothly inside it. The presence/absence of a jam is checked using the signals coming from the host machine at such times as programmed in the host machine. When the host machine detects a jam, the machine discharges all paper that has been picked up before the jam paper, and then stops the operation. The host machine offers instructions on how to remove jams on its control panel display.

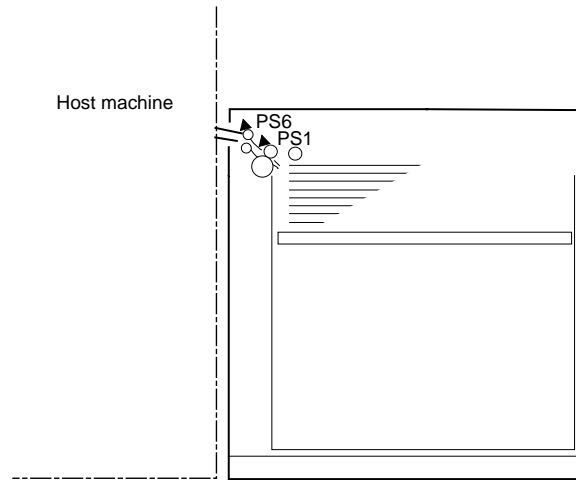

F-3-15

3.7.2 Types of Jams

T-3-4

Notation	Sensor	Delay jam	Stationary jam	Residue jam
PS1	Deck pickup sensor	yes	no	no
	Jam code indicated	011A	-	-
PS6	Deck pull-out sensor	yes	yes	yes
	Jam code indicated	011B	021B	0A1B

3.7.3 Sequence of Operations Used to Detect Jams

Deck Pickup Sensor Delay Jam

A delay jam will be identified if the deck pickup sensor does not go on within a specific period of time (including retry *) after the pickup start signal is issued.

- *: The number of times varies according to paper size.
- At normal speed: B4 and smaller size: 0 time, Larger than B4: 1 time
- At 1/2 speed: A4R and smaller size: 1 time, Larger than A4R: 2 times

Deck Pull-out Sensor Delay Jam

A delay jam will be identified if the time before the deck feed sensor goes on after the deck pickup sensor has gone on is longer than the logical time by an equivalent of 96.6 mm.

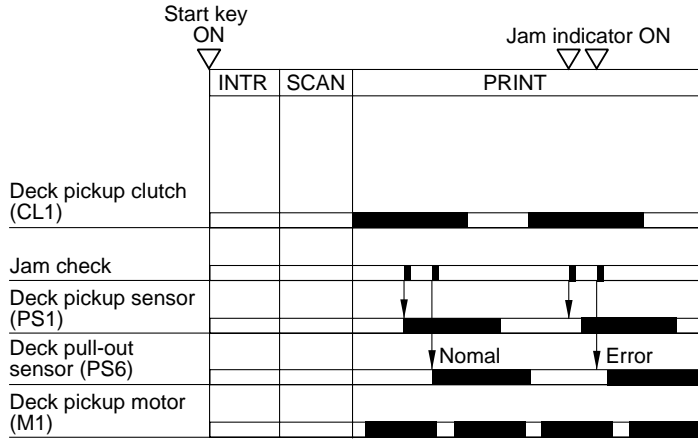

F-3-16

Deck Pull-out Sensor Stationary Jam

A stationary jam will be identified if the time before the deck pull-out sensor goes off after it has gone on is longer than the logical time by an equivalent of 30 mm.

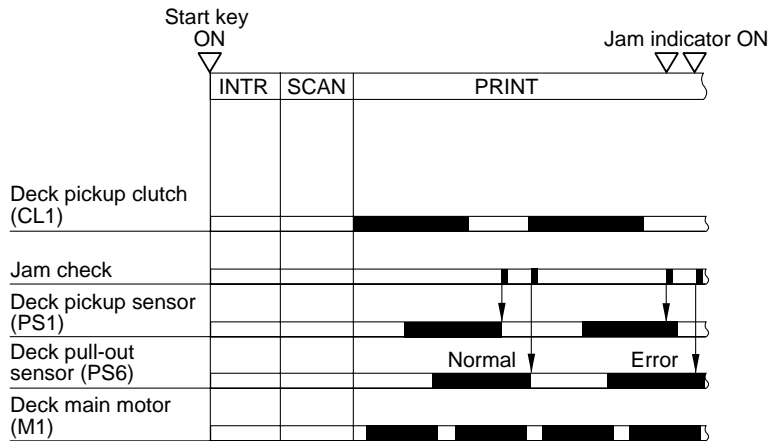

F-3-17

Residue Jam

A residue jam will be identified if paper exits over any sensor when the host machine is tuned on, is at the end of its warm-up period, or is in a standby state.

3.8 Power Supply

3.8.1 Power Supply

The machine's DC power supply is sent to the individual loads from the DC power supply PCB through the deck controller PCB (or directly). The voltage transformer circuit is found on the deck controller PCB and is used to turn 24 V into 30 V. The machine's AC power is supplied by an external power outlet, and it is sent through a leakage breaker (ELCB1) and noise filter (UN4) to reach the DC power supply PCB, cassette heater (H2, H3), and air heater (H1). The following diagram shows the AC power supply route to the power supply PCB together with the voltage generated by the individual power supply PCBs and the targets of the voltages.

The machine is equipped with a cassette heater switch (SW5), permitting switching over of the power to the cassette heater between 'supply normally' and 'do not supply normally'.

The table shows the heaters for which conditions of power supply differ depending on the setting of the cassette heater switch (SW5). The cassette heater may be set to suit different needs using service mode; however, it may go on even when the power switch is turned off as long as the power saving switch is on.

T-3-5

Leakage breaker (ELCB1)	Cassette heater switch (SW5)	Cassette heater (H2, H3)
ON	1(ON)	ON
ON	0(OFF)	OFF
OFF	1(ON)	OFF
OFF	0(OFF)	OFF

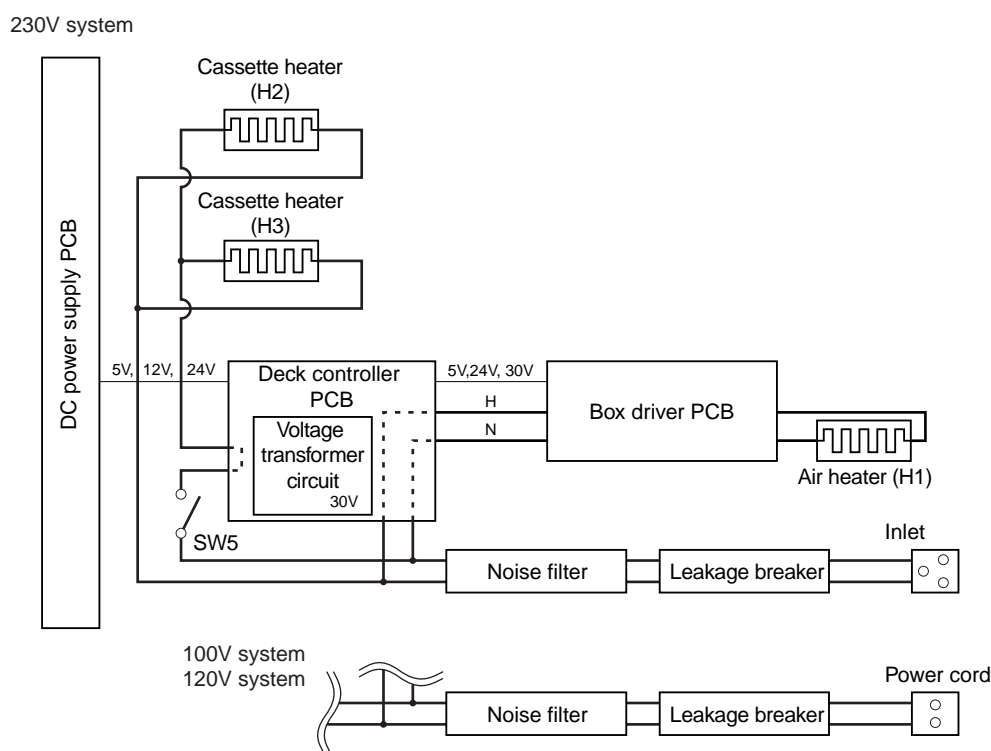

F-3-18

3.8.2 Protection Function

To protect the electrical parts, the fuses are mounted to the Deck Controller PCB.

In the case of overcurrent, the fuses are cut to protect respective electrical parts.

T-3-6

Fuse	Electrical Parts	Fuse	Electrical Parts
FU1	Deck lifter motor (M2)	FU5	Deck pickup motor (M1)
FU2	Heater (H1, H2, H3) AC for DC power supply	FU6	Additional fan (FM3)
FU3	Deck pickup sensor (PS1) Deck pull-out sensor (PS6)	FU7	Deck pickup clutch (CL1) Deck pickup roller release solenoid (SL1) Compartment open solenoid (right) (SL2) Compartment open solenoid (left) (SL3)
FU4	Motor cooling fan (FM4)		

The DC power supply has the overcurrent protective feature for the following:

- 5.0 V (max. 6 A)
- 12 V (max. 3 A)
- 24 V (max. 9 A)

The feature forcibly stops output in the case of overcurrent.

In the case of overcurrent, the leakage breaker is shut down or the fuse (FU2) is cut to protect the AC for the Heater and the DC power supply.

3.9 Fan

3.9.1 Overview

Following shows the list of Fans.

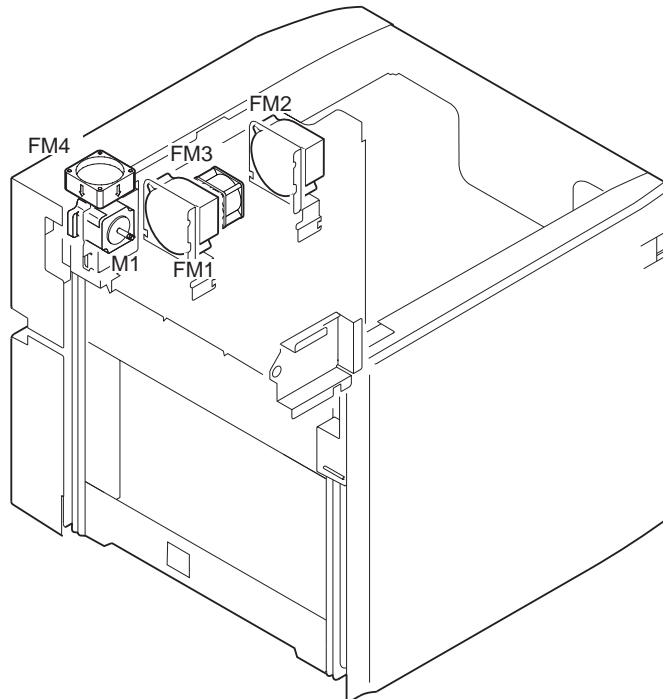

F-3-19
T-3-7

No.	Name	Function	Remarks
FM1	Warming fan	To improve separating performance of the paper	-
FM2	Cooling fan	To improve separating performance of the paper	-
FM3	Additional fan	To strengthen wind-power of the Warming Fan	-
FM4	Motor cooling fan	To cool the Deck Pickup Motor (M1)	-

Chapter 4 Parts Replacement Procedure

Contents

4.1 Removing from the Host Machine.....	4-1
4.1.1 Compartment.....	4-1
4.1.1.1 Removing from the Host Machine.....	4-1
4.1.1.2 Removing the Compartment.....	4-2
4.2 External Covers.....	4-3
4.2.1 Rear Cover.....	4-3
4.2.1.1 Removing the Rear Cover.....	4-3
4.2.2 Right Cover.....	4-4
4.2.2.1 Removing the Right Cover.....	4-4
4.2.3 Upper Cover.....	4-4
4.2.3.1 Removing the Upper Cover.....	4-4
4.3 Drive System.....	4-5
4.3.1 Pickup Motor.....	4-5
4.3.1.1 Preparation for Removing the Deck Pickup Motor.....	4-5
4.3.1.2 Removing the Deck Pickup Motor.....	4-5
4.3.2 Deck Pickup Clutch.....	4-6
4.3.2.1 Preparation for Removing the Deck Pickup Clutch.....	4-6
4.3.2.2 Removing the Deck Pickup Clutch.....	4-6
4.3.3 Deck Lifter Motor.....	4-6
4.3.3.1 Preparation for Removing the Deck Lifter Motor.....	4-6
4.3.3.2 Removing the Deck Lifter Motor.....	4-6
4.3.4 Lifter Cable (Front).....	4-7
4.3.4.1 Preparation for Removing the Lifter Cable (front).....	4-7
4.3.4.2 Removing the Lifter Cable (front).....	4-8
4.3.4.3 Routing the Lifter Cable.....	4-8
4.3.5 Lifter Cable.....	4-10
4.3.5.1 Preparation for Removing the Lifter Cable (rear).....	4-10
4.3.5.2 Removing the Lifter Cable (rear).....	4-10
4.3.5.3 Routing the Lifter Cable.....	4-11
4.3.6 Swing Motor.....	4-13
4.3.6.1 Preparation for Removing the Swing Motor.....	4-13
4.3.6.2 Removing the Swing Motor.....	4-13
4.4 Document Feeding System.....	4-14
4.4.1 Deck Pickup Unit.....	4-14
4.4.1.1 Preparation for Removing the Deck Pickup Unit.....	4-14
4.4.1.2 Removing the Deck Pickup Unit.....	4-14
4.4.2 Deck Pickup Roller.....	4-14
4.4.2.1 Preparation for Removing the Deck Pickup Roller.....	4-14
4.4.2.2 Removing the Deck Pickup Roller.....	4-14
4.4.3 Deck Pickup/Feed Roller.....	4-14
4.4.3.1 Preparation for Removing the Deck Pickup/Feed Roller.....	4-14
4.4.3.2 Removing the Deck Pickup/Feed Roller.....	4-14
4.4.4 Deck Separation Roller.....	4-14
4.4.4.1 Removing the Deck Separation Roller.....	4-14
4.5 Electrical System.....	4-15
4.5.1 Fan.....	4-15
4.5.1.1 Preparation for Removing the Cooling Fan/Warming Fan/Additional Fan.....	4-15
4.5.1.2 Removing the Cooling Fan.....	4-15
4.5.1.3 Removing the Warming Fan.....	4-15
4.5.1.4 Removing the Additional Fan.....	4-15
4.5.1.5 Preparation for Removing the Motor Cooling Fan.....	4-16
4.5.1.6 Removing the Motor Cooling Fan.....	4-16
4.5.2 Box Controller PCB.....	4-16

4.5.2.1 Preparation for Removing the Box Driver PCB	4-16
4.5.2.2 Removing the Box Driver PCB	4-16
4.5.3 Deck Controller PCB	4-16
4.5.3.1 Preparation for Removing the Deck Controller PCB	4-16
4.5.3.2 Removing the Deck Controller PCB	4-16
4.5.4 Open Switch PCB	4-17
4.5.4.1 Preparation for Removing the Open Switch PCB	4-17
4.5.4.2 Removing the Open Switch PCB	4-17
4.5.5 Environmental Sensor	4-18
4.5.5.1 Preparation for Removing the Environment Sensor	4-18
4.5.5.2 Removing the Environment Sensor	4-18
4.5.6 DC Power Supply PCB	4-18
4.5.6.1 Preparation for Removing the DC Power Supply PCB	4-18
4.5.6.2 Removing the DC Power Supply PCB	4-18
4.5.7 Deck Heater	4-18
4.5.7.1 Preparation for Removing the Cassette Heater	4-18
4.5.7.2 Removing the Cassette Heater	4-18
4.5.8 Air Heater	4-18
4.5.8.1 Preparation for Removing the Air Heater	4-18
4.5.8.2 Removing the Air Heater	4-19

4.1 Removing from the Host Machine

4.1.1 Compartment

4.1.1.1 Removing from the Host Machine

- 1) In humid environments, turn off the heater switch on the back of the paper deck.
- 2) Turn off the host machine's power switch.
- 3) Unplug the power cord [2] from the paper deck.
- 1 wire saddle [1]

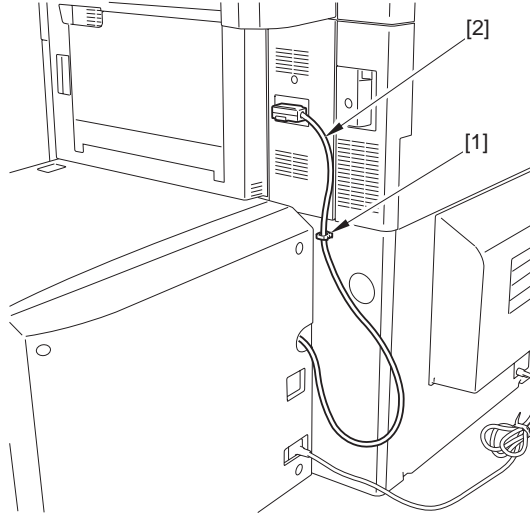

F-4-1

- 4) Turn the fixed adjusters [1] of the lower stay unit in the direction of the arrow.

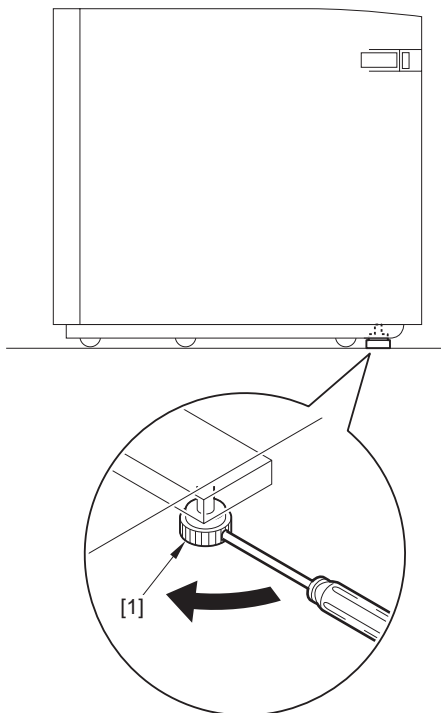

F-4-2

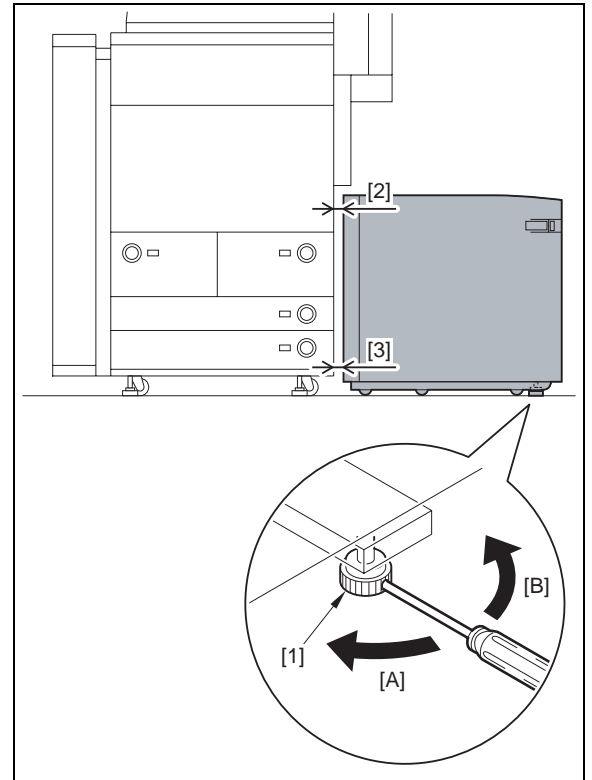

- 5) Pull the deck release handle [1] in the direction of the arrow to release the deck [2] from the host machine, and move the handle all the way to the right.

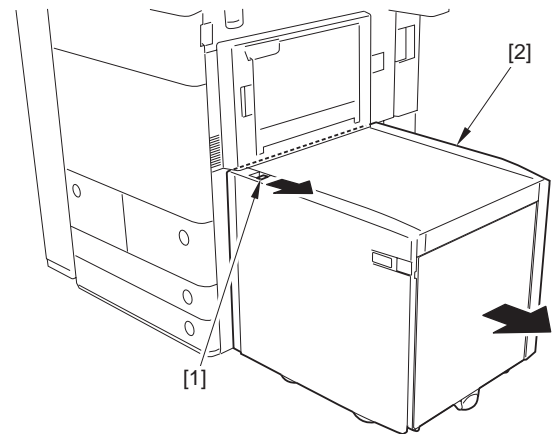

F-4-3

- 6) Remove the lower stay unit [2] from the host machine [3].
- 3 screws [1]

Notes:

When installing the paper deck, insert and turn the screwdriver in the adjusters [1] of the lower stay unit (two places) to raise or lower it for equal spacing between the paper deck and the host machine at the upper [2] and lower [3] mounting points.

- Turn in direction [A] to raise the paper deck.
- Turn in direction [B] to lower the paper deck.

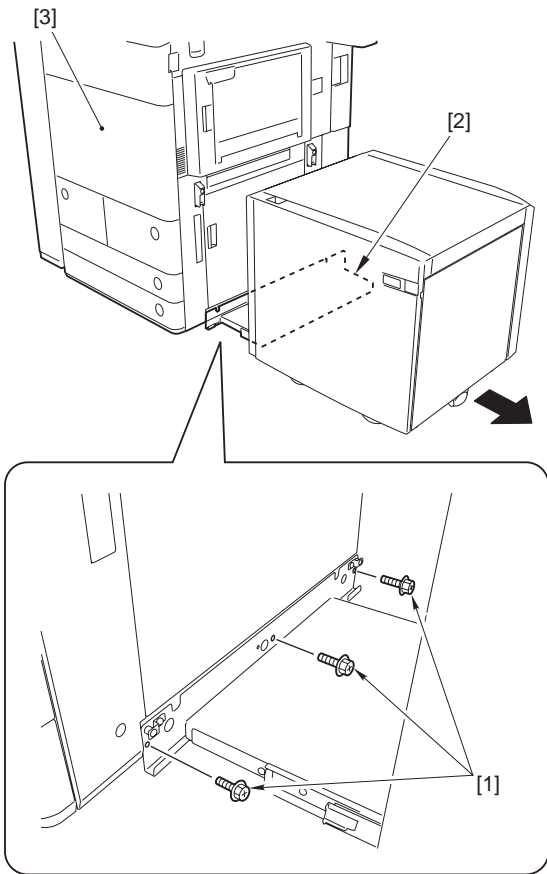

F-4-4

4.1.1.2 Removing the Compartment

1) Place a stack of paper [3] on the floor (about 6 cm high) to prevent deformation of the roll support plate [1].

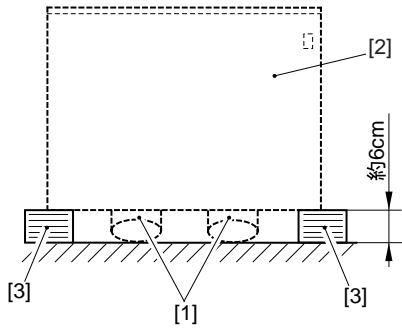

F-4-5

2) Pull the deck release handle [1] in the direction of the arrow to release the deck [2] from the host machine, and move the handle all the way to the right.

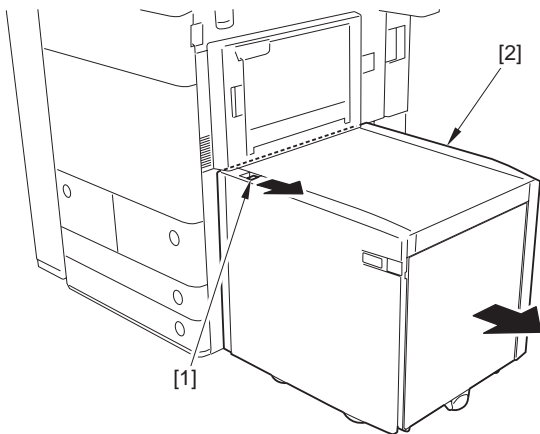

F-4-6

3) Insert a screwdriver etc. from the hole of plate [1] and push the left Re-

lease Lever [2] of the compartment downward.

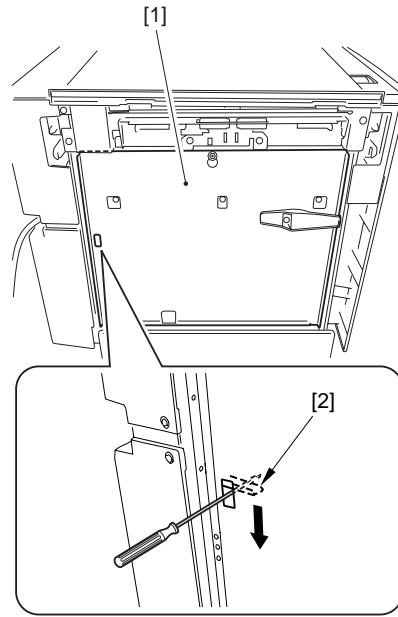

F-4-7

4) Fit a screwdriver into the hole [1] in the rear cover, and open the compartment.

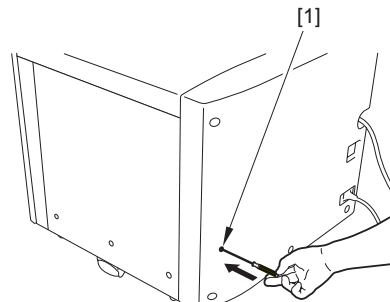

F-4-8

5) Remove the rear cover.
 6) Free the 2 harnesses [3].
 - 3 connectors [1]
 - 1 screw [2] each
 7) Route the 2 harnesses [3] through the hole [4] in the rear side plate into the machine inside.

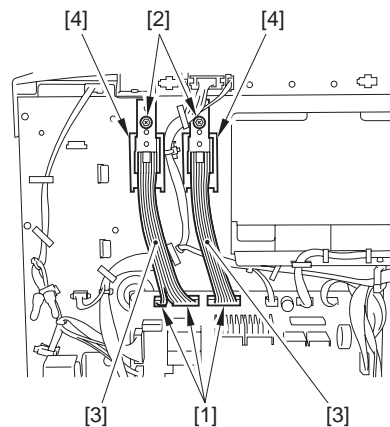

F-4-9

8) Place the stack of paper [1] prepared in step 1) on the left side of the compartment.
 9) Remove the 2 screws [2] used to hold the compartment left rail in place.

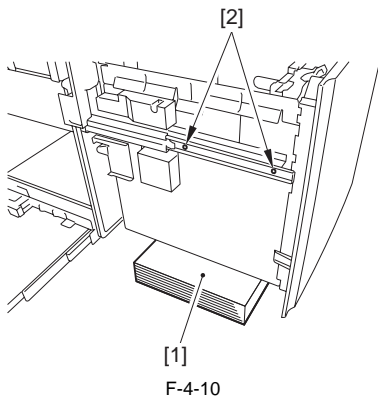

F-4-10

10) Place the stack of paper [1] prepared in step 1) on the right side of the compartment.
 11) Remove the 2 screws [2] used to hold the compartment right rail.

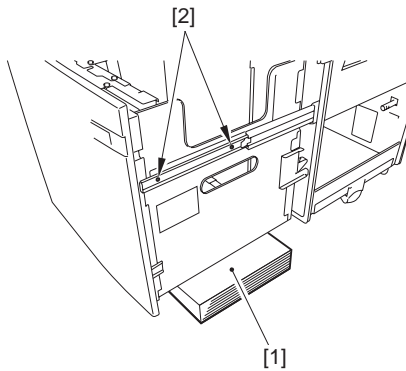

F-4-11

12) Lift the compartment slightly and remove the 2 guide pins [1] of the left rail.

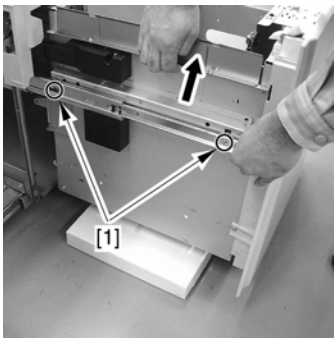

F-4-12

13) Put the compartment left rail [1] inside the machine, and place the compartment on the stand.

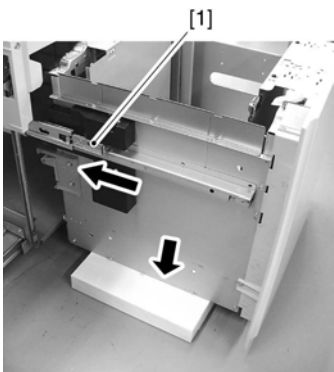

F-4-13

14) Lift the compartment slightly, and remove the 2 guide pins [1] of the right rail.

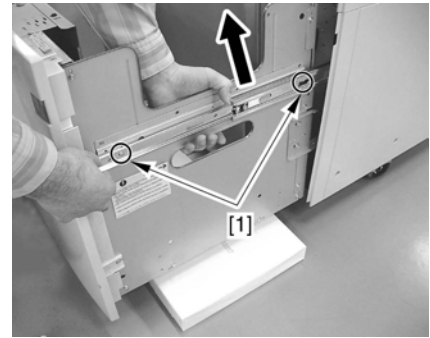

F-4-14

15) Put the compartment right rail [1] inside the machine, and place the compartment on the stand.

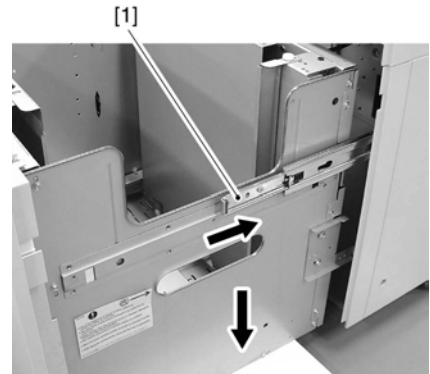

F-4-15

4.2 External Covers

4.2.1 Rear Cover

4.2.1.1 Removing the Rear Cover

1) Pull the deck release handle [1] in the direction of the arrow to release the deck [2] from the host machine, and move the handle all the way to the right.

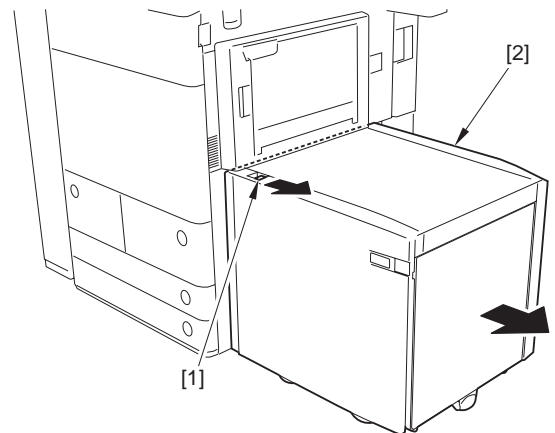

F-4-16

2) Remove the 7 screws [1], and detach the rear over [3] while leading the power cable [2] out of the hole.

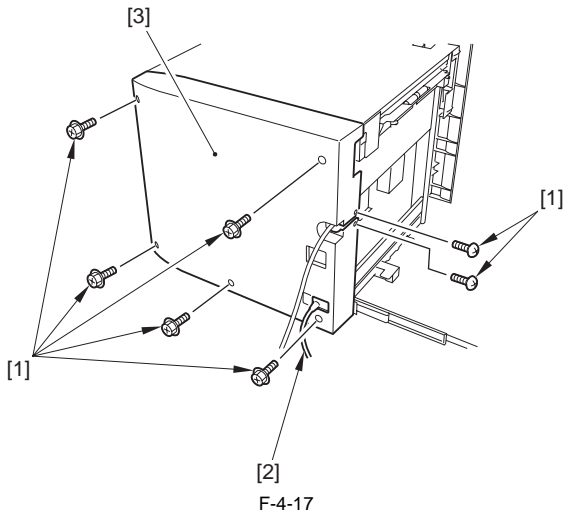

4.2.2 Right Cover

4.2.2.1 Removing the Right Cover

- 1) Pull the deck release handle [1] in the direction of the arrow to release the deck [2] from the host machine, and move the handle all the way to the right.

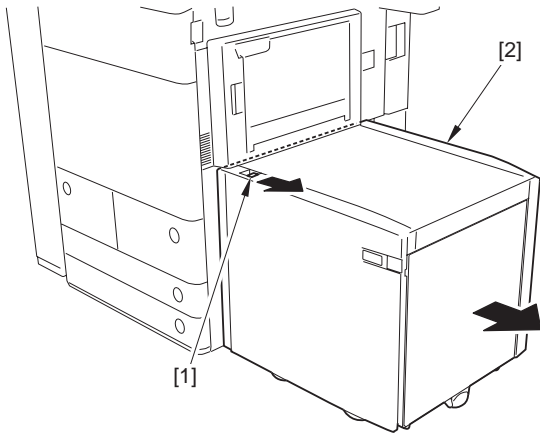

F-4-18

- 2) Insert a screwdriver etc. from the hole of plate [1] and push the left Release Lever [2] of the compartment downward.

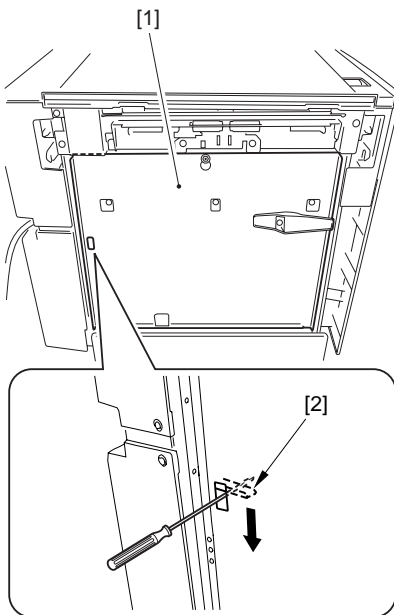

F-4-19

- 3) Fit a screwdriver into the hole [1] in the rear cover, and open the compartment.

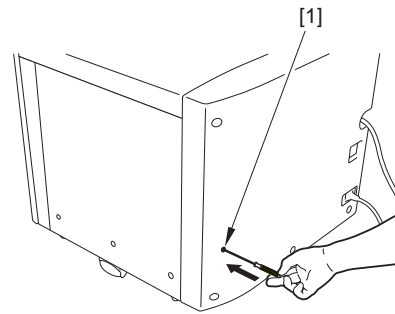

F-4-20

- 4) Remove the 3 screws [1], and move the right cover [2] downward and toward the front to detach.

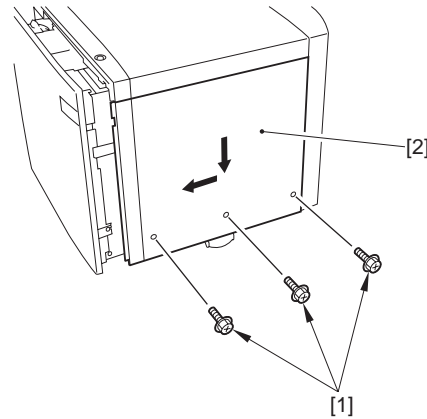

F-4-21

4.2.3 Upper Cover

4.2.3.1 Removing the Upper Cover

- 1) Pull the deck release handle [1] in the direction of the arrow to release the deck [2] from the host machine, and move the handle all the way to the right.

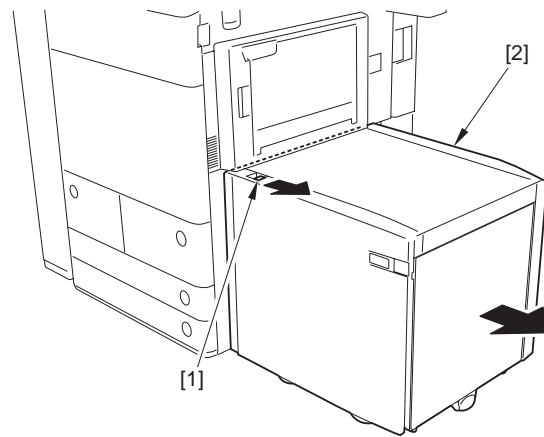

F-4-22

- 2) Insert a screwdriver etc. from the hole of plate [1] and push the left Release Lever [2] of the compartment downward.

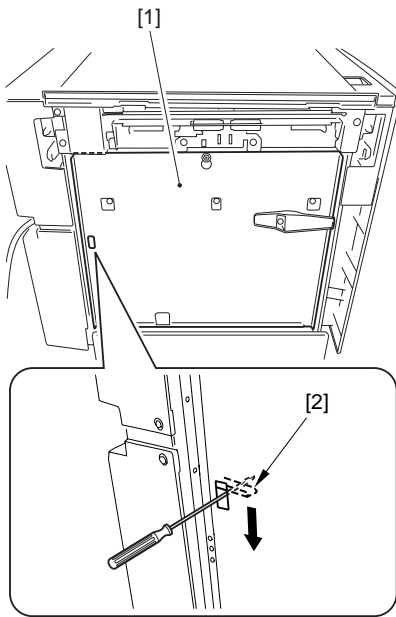

F-4-23

3) Fit a screwdriver into the hole [1] in the rear cover, and open the compartment.

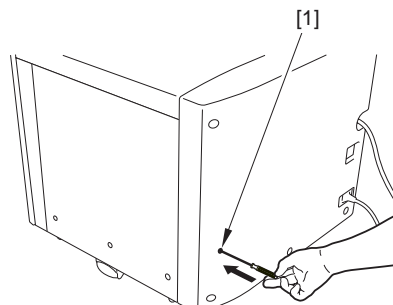

F-4-24

4) Remove the rear cover.
 5) Remove the upper front cover [3].
 - 4 screws [1]
 - 1 connector [2]

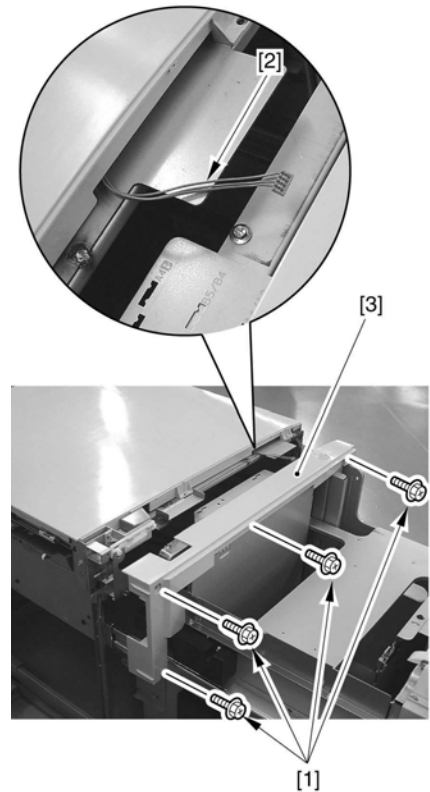

F-4-25

Note:
 To mount the upper front cover, take care not to trap the cable or leave the connectors disconnected.

6) Remove the 4 screws [1], and detach the upper cover [2].

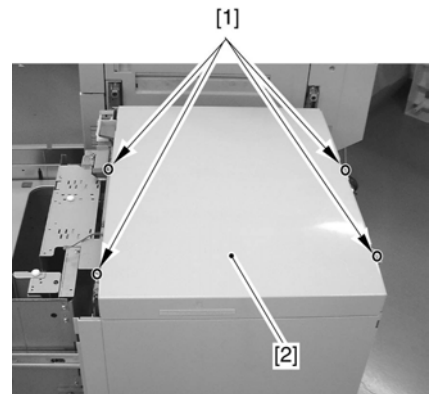

F-4-26

4.3 Drive System

4.3.1 Pickup Motor

4.3.1.1 Preparation for Removing the Deck Pickup Motor

- 1) Free the machine from its host machine.
- 2) Remove the rear cover. (page 4-3) Reference [Removing the Rear Cover]

4.3.1.2 Removing the Deck Pickup Motor

- 1) Remove the deck pickup motor [3].
 - 1 connector [1]
 - 2 screws [2]

Note:
 At this time, take care not to damage the gear found at the tip of the motor spindle.

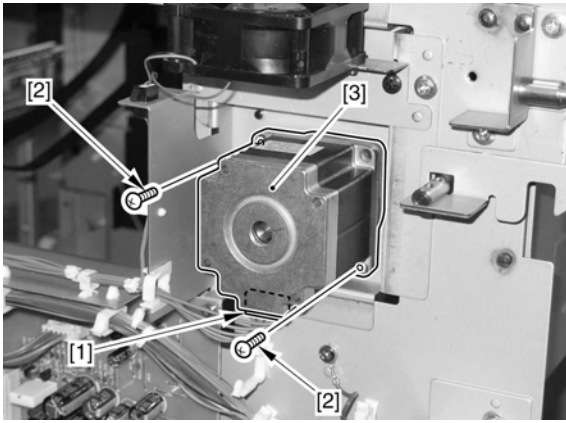

F-4-27

4.3.2 Deck Pickup Clutch

4.3.2.1 Preparation for Removing the Deck Pickup Clutch

- 1) Free the machine from its host machine.
- 2) Remove the rear cover. (page 4-3) Reference [Removing the Rear Cover]
- 3) Remove the upper cover. (page 4-4) Reference [Removing the Upper Cover]
- 4) Remove the deck pickup unit. (page 4-14) Reference [Removing the Deck Pickup Unit]

4.3.2.2 Removing the Deck Pickup Clutch

- 1) Remove the deck pickup clutch [3].
 - 1 connector [1]
 - 1 E-ring [2]

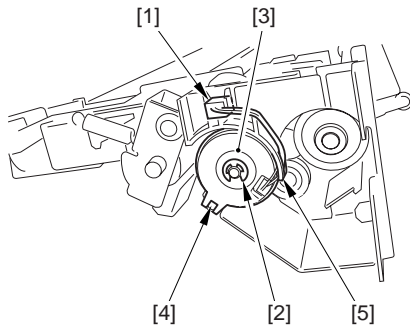

F-4-28

Note:
When mounting the deck pickup clutch, be sure to fit the stop [4] to the clutch. Also, be sure that the harness is fitted in the U-groove [5] of the guide.

4.3.3 Deck Lifter Motor

4.3.3.1 Preparation for Removing the Deck Lifter Motor

Note:
The lifter must remain down for the work, calling for the power to be turned on before starting the work. Take extra care not to trap your hands, fingers, and clothes and to avoid electric shocks.

- 1) With the host machine turned on, press the open button to open the compartment.
If there is paper, remove all of it.
- 2) If the lifer is up, push the sensor lever [1] of the supply sensor found inside the compartment to stop the lifter [2] about 7 cm from the bottom plate of the compartment.

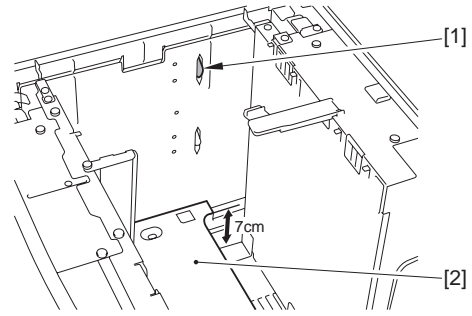

F-4-29

- 3) Remove the 2 screws [1], and move the side guide plate (front) [2] fully toward the front.

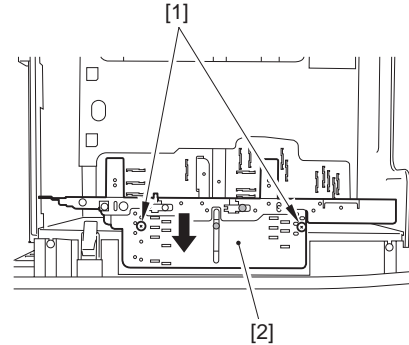

F-4-30

- 4) Fit a hex wrench [2] into the hole in the lifter drive shaft [1] so that the shaft will not rotate.

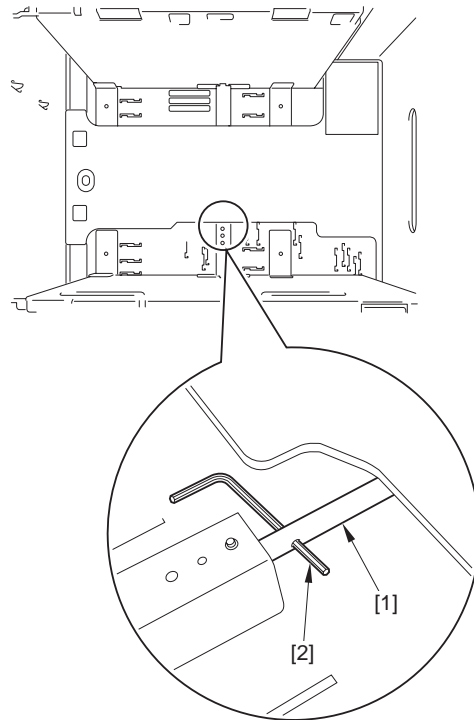

F-4-31

- 5) Turn off the host machine.
- 6) Close the compartment.
- 7) Remove the rear cover. (page 4-3) Reference [Removing the Rear Cover]

4.3.3.2 Removing the Deck Lifter Motor

- 1) Remove the 2 screws [1], and detach the lifter motor cover [2].

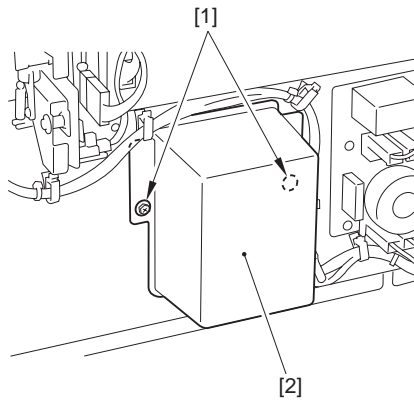

F-4-32

- 2) Remove the deck lifter motor unit [3].
 - 1 connector [1]
 - 2 screws [2]

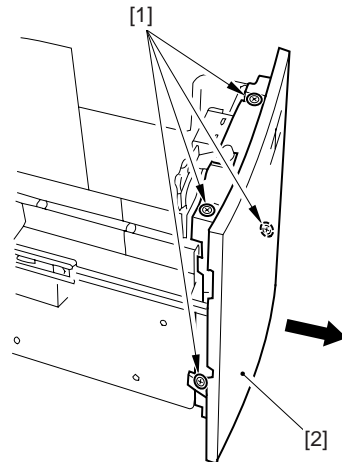

F-4-35

Note:
 When mounting the front cover [1], try correctly positioning the coupling [2] of the paper level indicator.

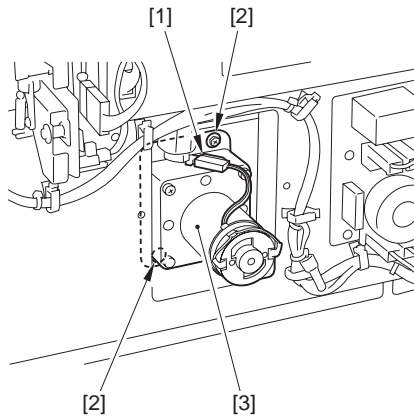

F-4-33

4.3.4 Lifter Cable (Front)

4.3.4.1 Preparation for Removing the Lifter Cable (front)

Note:
 The lifter must remain down for the work, calling for the machine to be turned on before starting the work. Take extra care not to trap your hands, fingers, and clothes and to avoid electrical shocks.

- 1) With the host machine turned on, press the open button to open the compartment.
 If there is paper, remove all of it.
- 2) If the lifer is up, push the sensor lever [1] of the supply sensor found inside the compartment so that the lifer is at its lower limit.

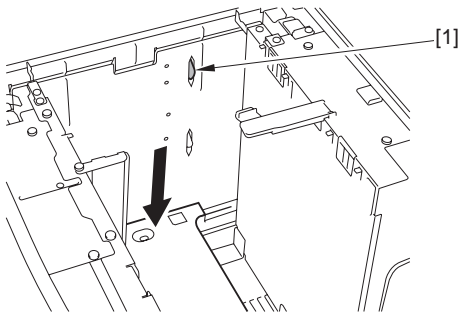

F-4-34

- 3) Turn off the host machine.
- 4) Loosen the 4 screws [1], and detach the machine's front cover [2] toward the front.

Note:
 When removing the front cover, make note of the scale markings around the four mounting screws.

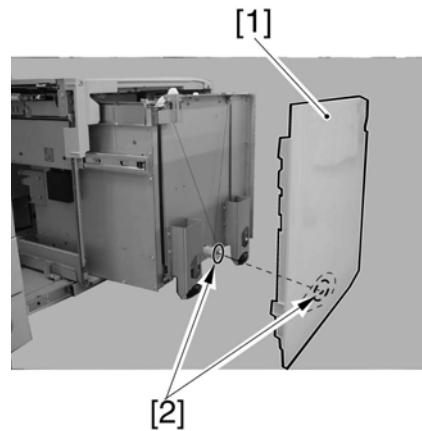

Note:
 Mount the front cover [1] so that the gap to the upper front cover [2] is 3 +/- 1 mm.

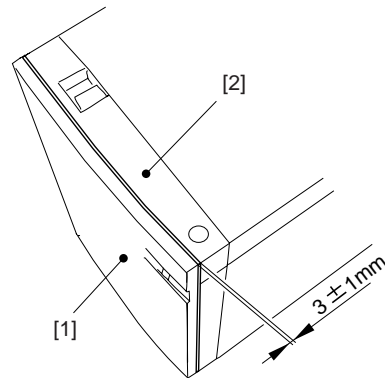

Note:
 If you happen to have moved the paper level indicator drive belt found behind the front cover by hand and lost reference to its initial position as a result, or shifted the lifter, move the lifter to its lower limit, and turn the drive gear [2] in the direction that increases the white area of the display window [1] (in the direction of the arrow) until it stops before attaching the front cover. (If you operate the machine without matching the paper level indicator and the lifer position, the drive system of the paper indicator can suffer damage.)

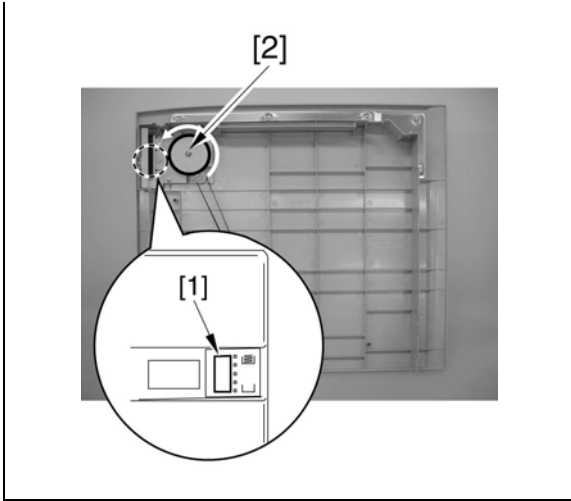

4.3.4.2 Removing the Lifter Cable (front)

- 1) Remove the pulley cover [3].
 - 1 coupling [1]
 - 1 E-ring [2]

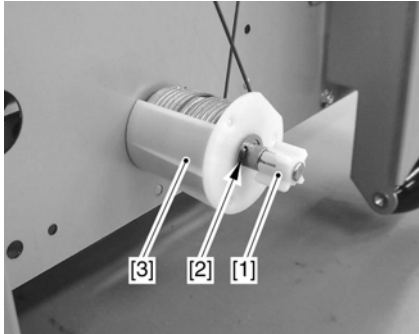

F-4-36

- 2) Remove the lifter cable [3] found on the outside.
 - 2 screws [1]
 - cable fixing plate [2] found on the left side
- 3) Remove the lifter cable [6] found on the inside.
 - 2 screws [4]
 - cable fixing plate [5] found on the right side

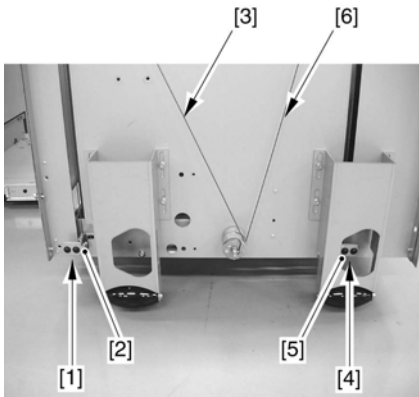

F-4-37

- 4) As necessary, loosen the 2 set screws [3] of the outside pulley [4] and remove the pulley before detaching the lifter cable [2] found on the inside from the inside pulley [1].

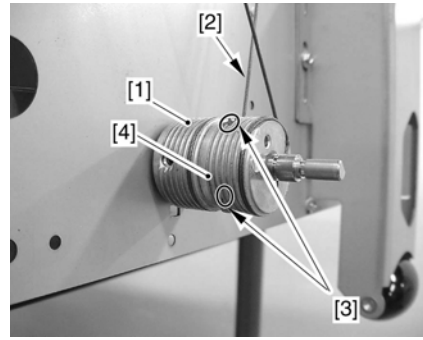

F-4-38

4.3.4.3 Routing the Lifter Cable

- 1) Insert the hex wrench [1] into the hole of the lifter drive shaft to fix the lifter drive shaft. (To prevent rotating)
- 2) Load papers [2] (approx. 500 sheets) on the lifter to fix the lifter.
- 3) Fix the cable fixing plate [3] to the lifter by the two screws.
- 4) Hook the lifter cable on the upper pulley [4].
- 5) Hook the ball of the lifter cable on the pulley [5] of the lifter drive shaft; then, wind it along the groove of the pulley about one time. At this time, be sure that the lifter cable is taut.
- 6) In this condition, secure the pulley to the lifter drive shaft using two set screws [6].
- 7) After securing all pulleys that have been removed to the lifter drive shaft, measure the distance from the bottom plate of the compartment to the top face of the lifter, and make sure that the lifter is level.
- 8) Remove the turn-proof hexagonal wrench.

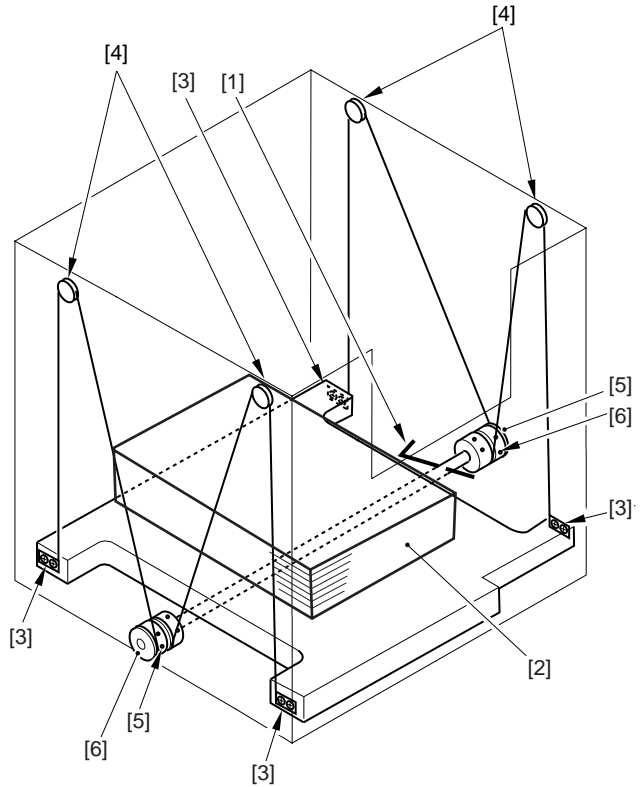

F-4-39

⚠
Ensure to remove the hexagonal wrench.

- 9) Place a sheet of paper on the Deck Tray and close the deck.
- 10) Turn ON the power of the Host Machine and wait until the Lifter is brought up and stopped.
- 11) Turn OFF the power of the Host Machine.
- 12) Push the Release Lever to release this equipment from the Host Machine, and then move it all the way to the right.

- 13) Insert a screwdriver etc. from the hole of plate [1] and push the left Release Lever [2] of the compartment downward.

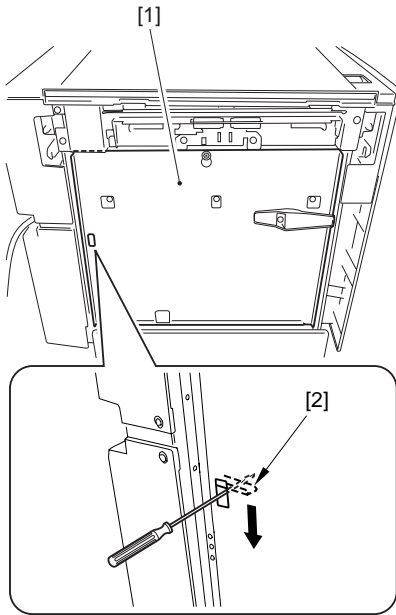

F-4-40

- 14) Put a screwdriver to the hole [1] on the Rear Cover to open the deck.

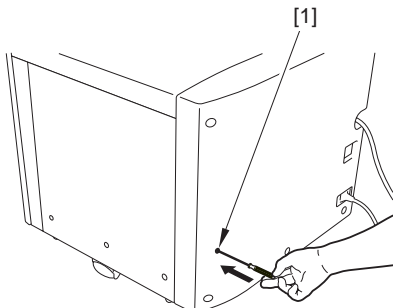

F-4-41

MEMO:

If the deck fails to be open, perform step 13) and 14) in the reverse order.

- 15) Measure the height from the Pre-Separation Plate [2] to the top of the Lifter [1] at 2 points (front and rear) and check that the Lifter [1] is positioned parallel to the Pre-Separation Plate [2].
In the case of serious disconformable, start all over again from step 1).

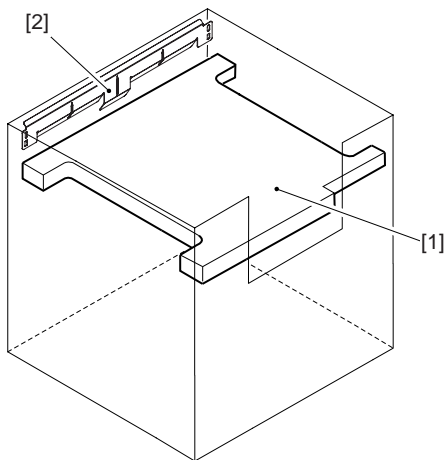

F-4-42

4.3.5 Lifter Cable

4.3.5.1 Preparation for Removing the Lifter Cable (rear)

Note:

The lifter must remain down for the work, calling for the machine to be turned on before starting the work. Take full care not to trap your hands, fingers, and clothes and to avoid electric shocks.

- 1) With the host machine on, push the open button to open the compartment. If there is any paper, remove all of it.
- 2) If the lifter is up, push the sensor lever [1] of the supply sensor found inside the compartment so that the lifter moves to its lower limit.

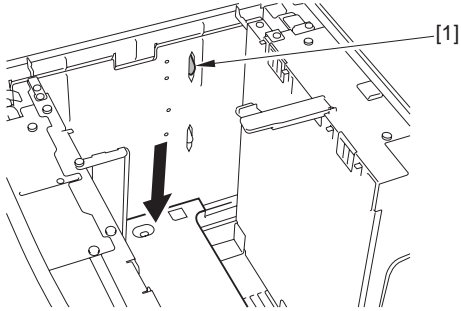

F-4-43

- 3) Turn off the host machine.
- 4) Remove the compartment. (page 4-2) Reference [Removing the Compartment]
- 5) Remove the screw [1] (1 pc. each), and detach the left/right sensor plate [2] (1 pc. each).

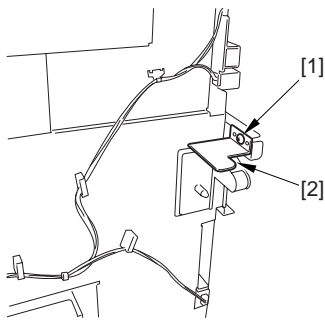

F-4-44

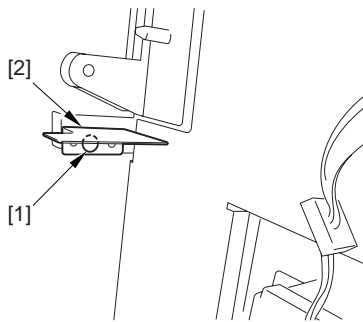

F-4-45

- 6) Remove the plate [5].
 - 9 connectors [1]
 - 1 reuse clamp [2]
 - 5 screws [3]
 - 13 cable clamps [4]

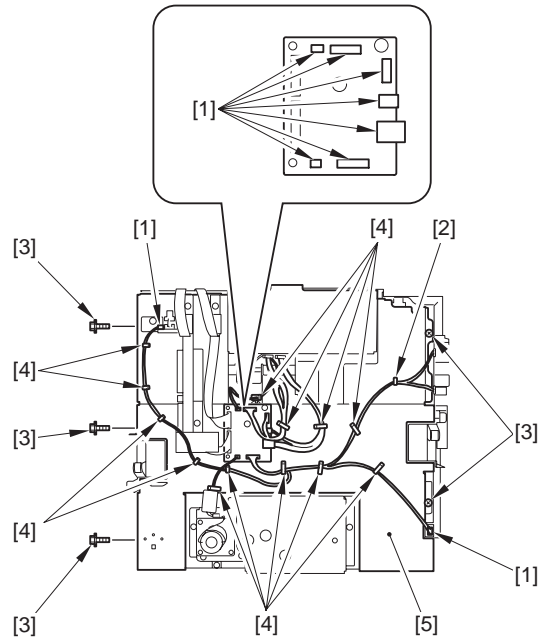

F-4-46

- 7) Remove the 2 screws [1], and detach the lifter motor [2].

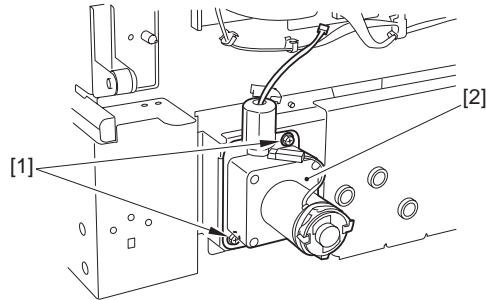

F-4-47

- 8) Remove the 2 screws [1], and detach the drive support plate [2].

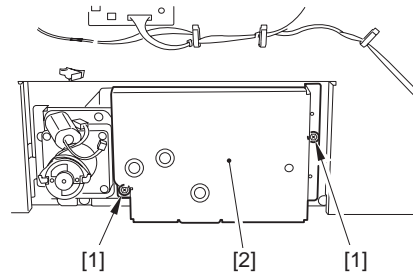

F-4-48

- 9) Remove the bearing [1] and the gear [2].

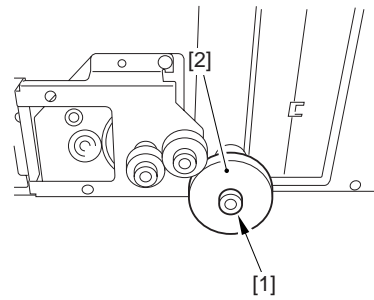

F-4-49

4.3.5.2 Removing the Lifter Cable (rear)

- 1) Remove the pulley cover [3].
 - 1 parallel pin [1]
 - 1 E-ring [2]

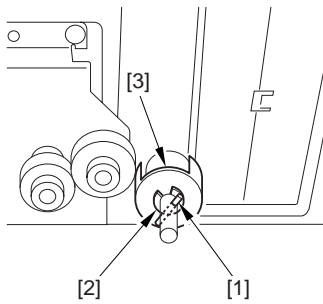

F-4-50

- 2) Remove the lifter cable [3] found on the outside.
 - 2 screws [1]
 - cable fixing plate [2] (right side)
- 3) Remove the lifter cable [6] found on the inside.
 - 2 screws [4]
 - cable fixing plate [5] (left side)

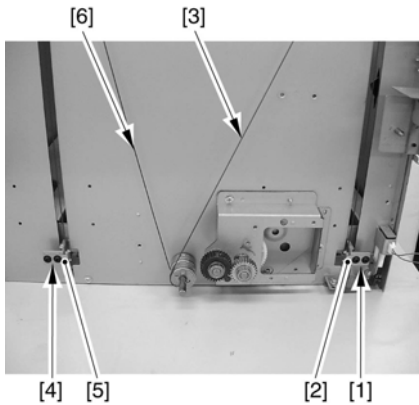

F-4-51

- 4) As necessary, detach the lifter cable [2] (inside) from the inside pulley [1] by first loosening the 2 set screws [3] and removing the outside pulley [4].

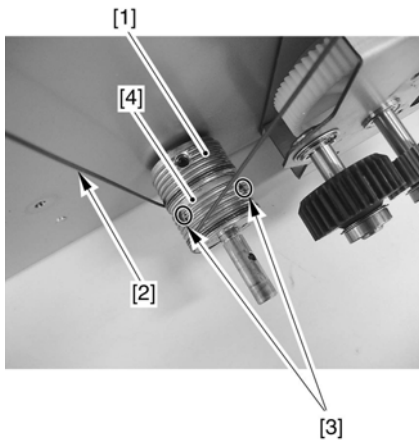

F-4-52

4.3.5.3 Routing the Lifter Cable

- 1) Insert the hex wrench [1] into the hole of the lifter drive shaft to fix the lifter drive shaft. (To prevent rotating)
- 2) Load papers [2] (approx. 500 sheets) on the lifter to fix the lifter.
- 3) Fix the cable fixing plate [3] to the lifter by the two screws.
- 4) Hook the lifter cable on the upper pulley [4].
- 5) Hook the ball of the lifter cable on the pulley [5] of the lifter drive shaft; then, wind it along the groove of the pulley about one time. At this time, be sure that the lifter cable is taut.
- 6) In this condition, secure the pulley to the lifter drive shaft using two set screws [6].
- 7) After securing all pulleys that have been removed to the lifter drive shaft, measure the distance from the bottom plate of the compartment to the top face of the lifter, and make sure that the lifter is level.
- 8) Remove the turn-proof hexagonal wrench.

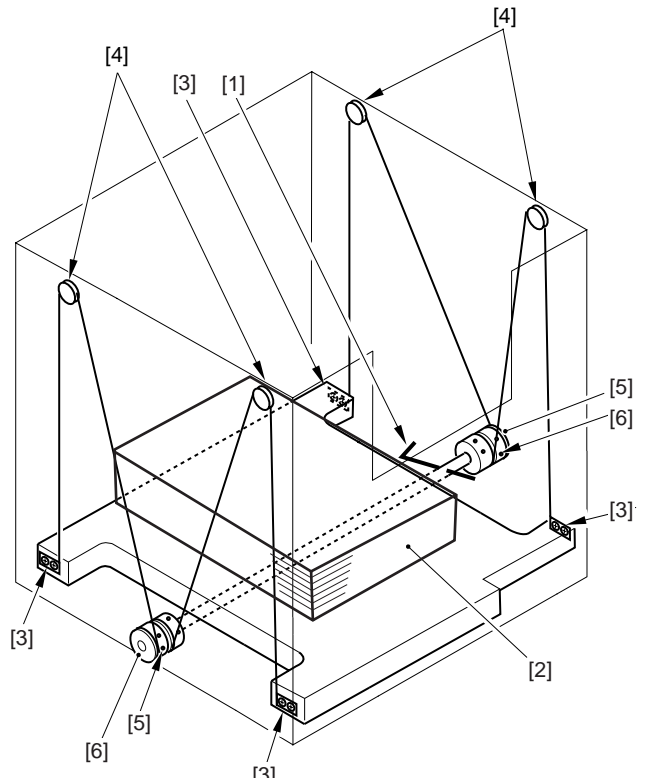

F-4-53

 Ensure to remove the hexagonal wrench.

- 9) Place a sheet of paper on the Deck Tray and close the deck.
- 10) Turn ON the power of the Host Machine and wait until the Lifter is brought up and stopped.
- 11) Turn OFF the power of the Host Machine.
- 12) Push the Release Lever to release this equipment from the Host Machine, and then move it all the way to the right.
- 13) Insert a screwdriver etc. from the hole of plate [1] and push the left Release Lever [2] of the compartment downward.

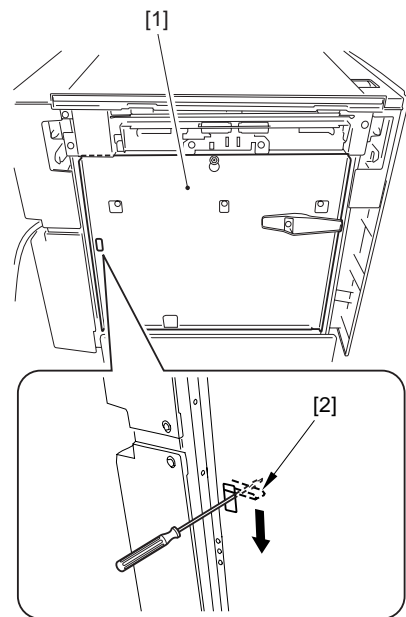

F-4-54

14) Put a screwdriver to the hole [1] on the Rear Cover to open the deck.

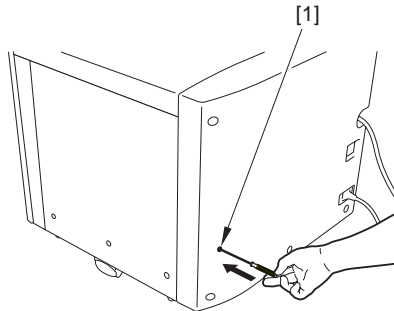

F-4-55

MEMO:
If the deck fails to be open, perform step 13) and 14) in the reverse order.

15) Measure the height from the Pre-Separation Plate [2] to the top of the Lifter [1] at 2 points (front and rear) and check that the Lifter [1] is positioned parallel to the Pre-Separation Plate [2].
In the case of serious disconformable, start all over again from step 1).

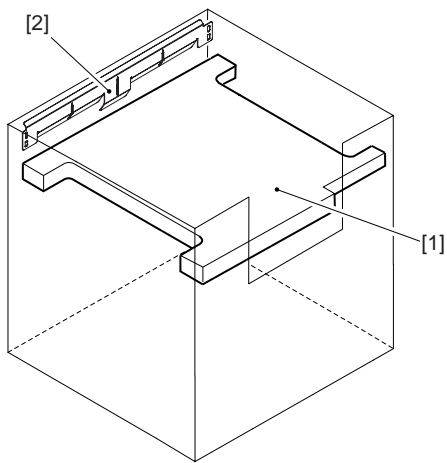

F-4-56

4.3.6 Swing Motor

4.3.6.1 Preparation for Removing the Swing Motor

- 1) Remove the compartment. (page 4-2)Reference [Removing the Compartment]
- 2) Remove the side guide plate (rear).
 - 2-1) Remove 2 screws [1], and 2 coin screws [2].
 - 2-2) Remove the screw [3], and detach the fixing [4].

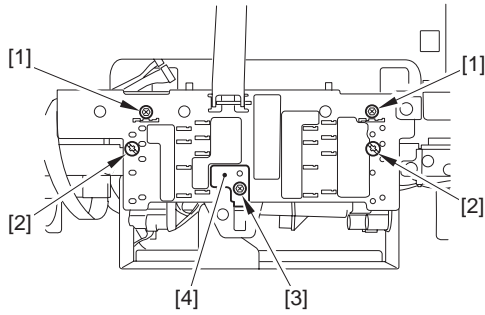

F-4-57

- 2-3) Disconnect the 5 connectors [1], and remove the 3 cable clamps [2].

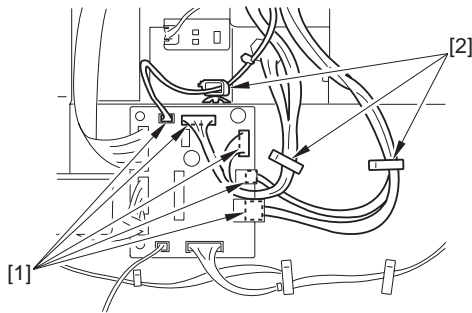

F-4-58

- 2-4) Move the side guide plate (rear) [1] toward the front to detach.

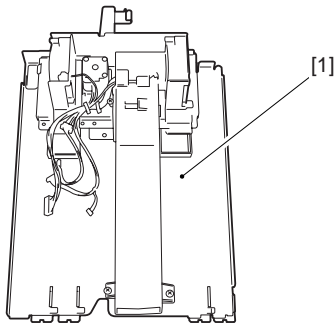

F-4-59

- 3) Remove the duct [6].
 - 1 screws [1]
 - 2 step screws [2]
 - 1 cable clamp [3]
 - 1 connector [4]
 - 2 cable guides [5]

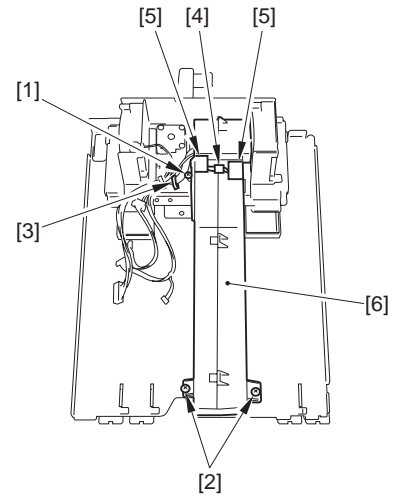

F-4-60

4.3.6.2 Removing the Swing Motor

- 1) Remove the swing motor [5].
 - 1 screws [1]
 - 2 screws [2]
 - 1 relay cable [3]
 - 1 cable clamp [4]

MEMO:
The plate used to hold the swing motor [6] in place will come off as soon as the screw [1] is removed.

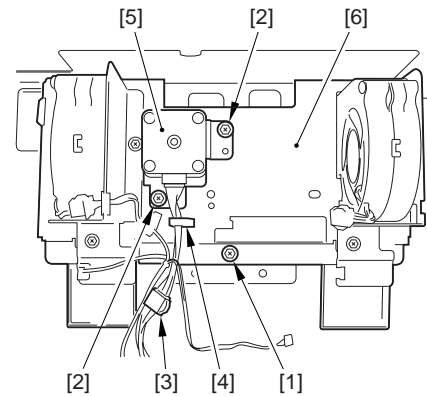

F-4-61

Note:
When mounting the motor to the plate, loosen the screw [1] once, and fit the belt [2] as shown before tightening back the screw.

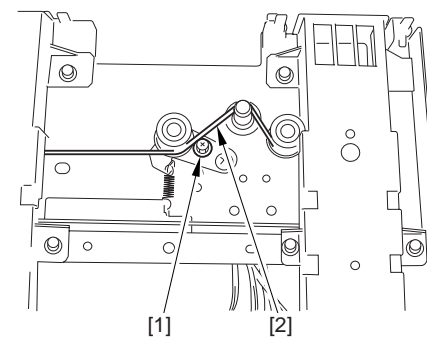

4.4 Document Feeding System

4.4.1 Deck Pickup Unit

4.4.1.1 Preparation for Removing the Deck Pickup Unit

- 1) Free the machine from its host machine.
- 2) Remove the rear cover. (page 4-3) Reference [Removing the Rear Cover]
- 3) Remove the upper cover. (page 4-4) Reference [Removing the Upper Cover]

4.4.1.2 Removing the Deck Pickup Unit

- 1) Remove the deck pickup unit [4].
 - 1 connector [1]
 - 4 wire saddles [2]
 - 5 screws [3]

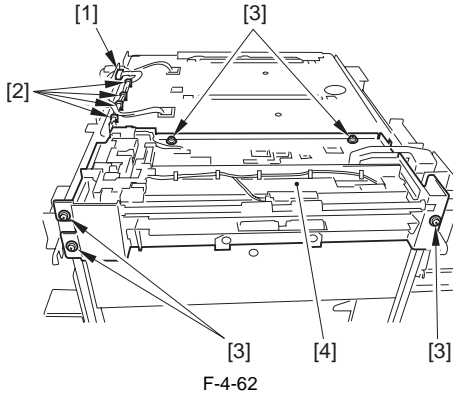

F-4-62

Note:
When mounting the deck pickup unit [1], be sure to fit the 3 screws [2] first.

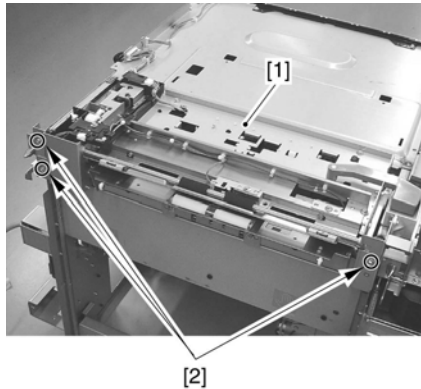

4.4.2 Deck Pickup Roller

4.4.2.1 Preparation for Removing the Deck Pickup Unit

- 1) Free the machine from its host machine.
- 2) Remove the rear cover. (page 4-3) Reference [Removing the Rear Cover]
- 3) Remove the upper cover. (page 4-4) Reference [Removing the Upper Cover]
- 4) Remove the deck pickup unit. (page 4-14) Reference [Removing the Deck Pickup Unit]

4.4.2.2 Removing the Deck Pickup Roller

- 1) Turn over the deck pickup unit.
- 2) Remove the resin ring [1] (1 pc. each), and detach the 2 deck pickup rollers [2].

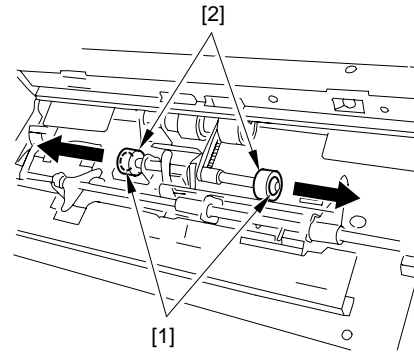

F-4-63

4.4.3 Deck Pickup/Feed Roller

4.4.3.1 Preparation for Removing the Deck Pickup/Feed Roller

- 1) Free the machine from its host machine.
- 2) Remove the rear cover. (page 4-3) Reference [Removing the Rear Cover]
- 3) Remove the upper cover. (page 4-4) Reference [Removing the Upper Cover]
- 4) Remove the deck pickup unit. (page 4-14) Reference [Removing the Deck Pickup Unit]

4.4.3.2 Removing the Deck Pickup/Feed Roller

- 1) Turn over the deck pickup unit.
- 2) Remove the resin ring [1], and detach the deck pickup/feed roller [2] and the drive belt [3] toward the front.

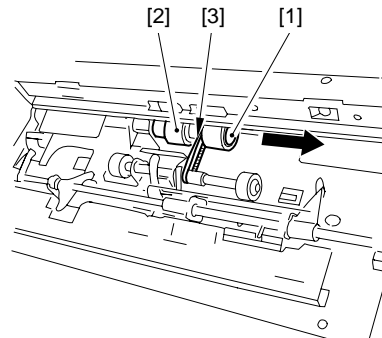

F-4-64

4.4.4 Deck Separation Roller

4.4.4.1 Removing the Deck Separation Roller

- 1) Free the machine from its host machine.
- 2) Remove the 2 screws [1], and detach the separation roller support plate [2].

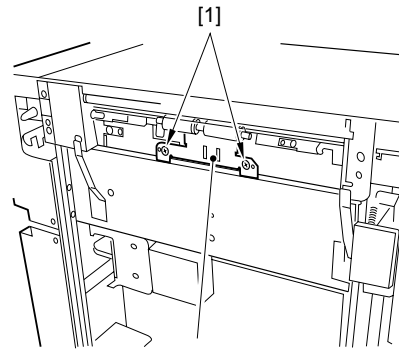

F-4-65

- 3) Remove the joint, and detach the deck separation roller [1].

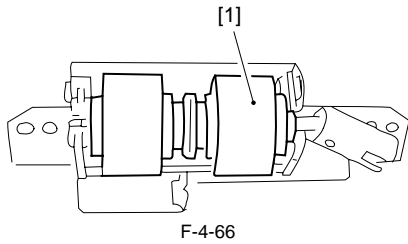

MEMO:
 The urethane sponge used on the deck separation roller changes color from pink to orange and then to yellow over time, the change being accelerated if exposed to light. The symptom is a general characteristic of urethane sponge, and there is no difference in performance in relation to color. Keep in mind that the color of the sponge does not indicate a particular type.

4.5 Electrical System

4.5.1 Fan

4.5.1.1 Preparation for Removing the Cooling Fan/Warming Fan/Additional Fan

- 1) Remove the compartment. (page 4-2) Reference [Removing the Compartment]
- 2) Remove the side guide plate (rear).
 - 2-1) Remove 2 screws [1], and 2 coin screws [2].
 - 2-2) Remove the screw [3], and detach the fixing [4].

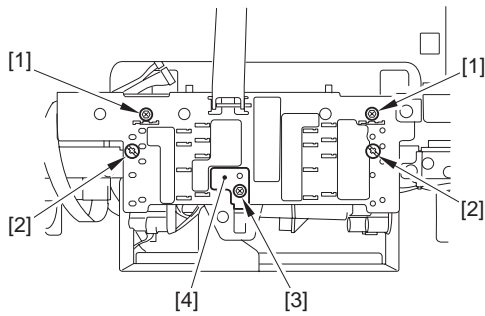

- 2-3) Disconnect the 5 connectors [1], and remove the 3 cable clamps [2].

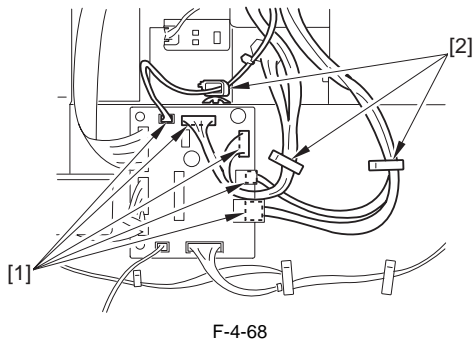

- 2-4) Move the side guide plate (rear) [1] toward the front to detach.

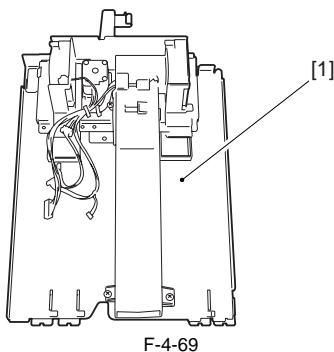

4.5.1.2 Removing the Cooling Fan

- 1) Remove the cooling fan [3].
 - 2 screws [1]
 - 1 connector [2]

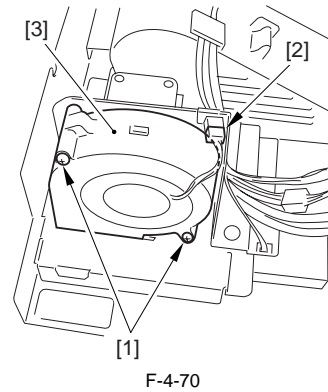

4.5.1.3 Removing the Warming Fan

- 1) Remove the fan base [3].
 - 2 screws [1]
 - 1 connector [2]

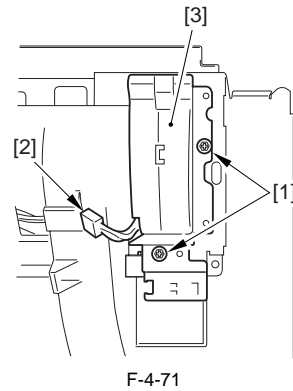

- 2) Remove the 2 screws [1], and detach the warming fan [2].

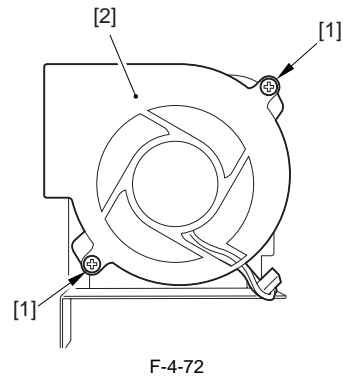

4.5.1.4 Removing the Additional Fan

- 1) Remove the duct [6].
 - 1 screws [1]
 - 2 step screws [2]
 - 1 cable clamp [3]
 - 1 connector [4]
 - 2 cable guides [5]

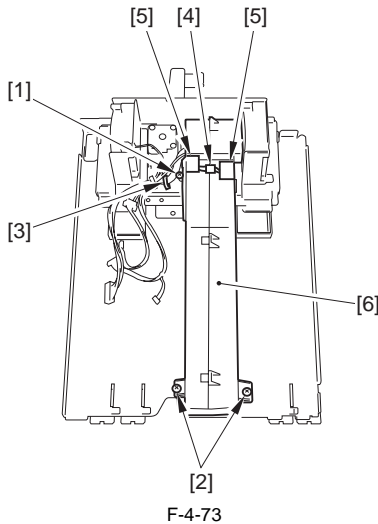

F-4-73

2) Remove the 3 screws [1], and open the duct [2].

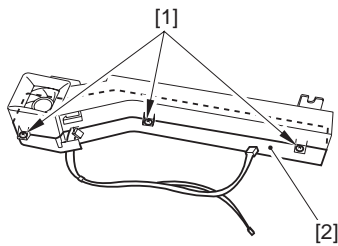

F-4-74

Note:
To close the duct, be sure to match the protrusion [1] of the air heater and the mold receiving side [2].

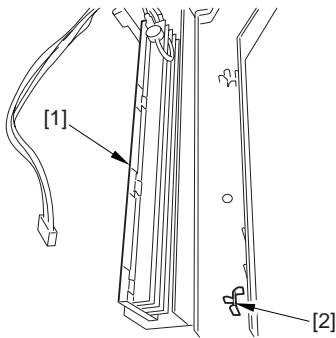

3) Remove the 2 screws [1], and detach the additional fan [2].

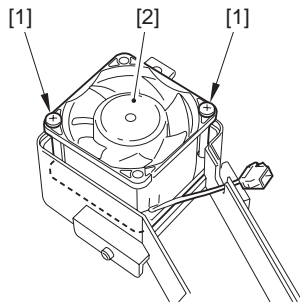

F-4-75

4.5.1.5 Preparation for Removing the Motor Cooling Fan

- 1) Free the machine from its host machine.
- 2) Remove the rear cover.

4.5.1.6 Removing the Motor Cooling Fan

- 1) Remove the motor cooling fan [3].
 - 1 connector [1]
 - 2 screws [2]

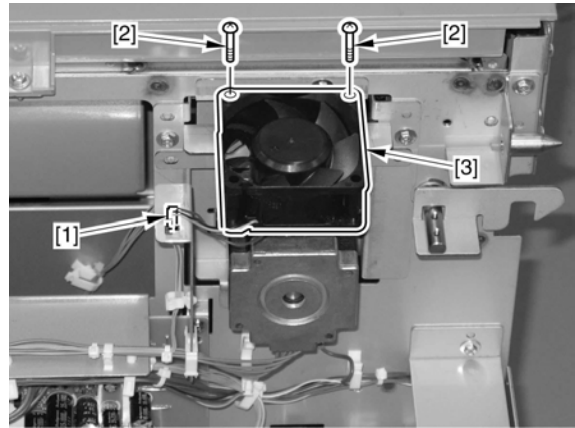

F-4-76

4.5.2 Box Controller PCB

4.5.2.1 Preparation for Removing the Box Driver PCB

- 1) Free the machine from its host machine.
- 2) Remove the compartment. (page 4-2) Reference [Removing the Compartment]

4.5.2.2 Removing the Box Driver PCB

- 1) Remove the box driver PCB [4].
 - 10 connectors [1]
 - 1 screw [2]
 - 3 card spacers [3]

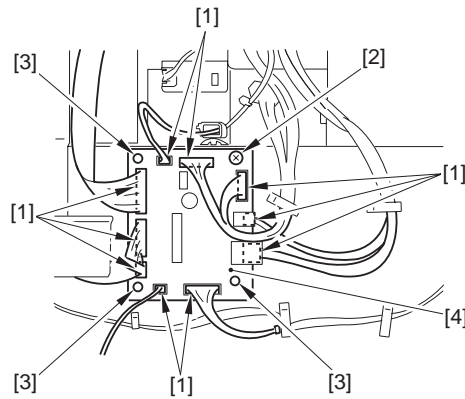

F-4-77

4.5.3 Deck Controller PCB

4.5.3.1 Preparation for Removing the Deck Controller PCB

- 1) Free the machine from its host machine.
- 2) Remove the rear cover. (page 4-3) Reference [Removing the Rear Cover]

4.5.3.2 Removing the Deck Controller PCB

- 1) Remove the deck controller PCB [4].
 - 16 connectors [1]
 - 4 screws [2]
 - 2 card spacers [3]

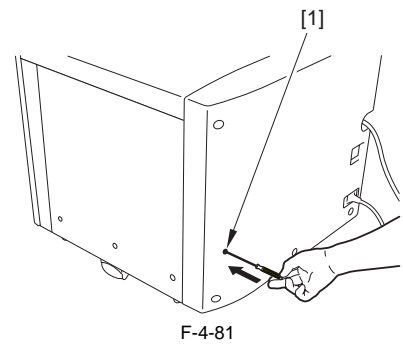
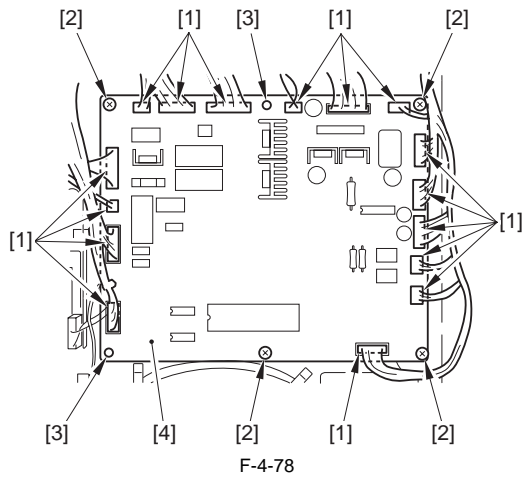

- 4) Remove the upper front cover [3].
 - 4 screws [1]
 - 1 connector [2]

4.5.4 Open Switch PCB

4.5.4.1 Preparation for Removing the Open Switch PCB

- 1) Pull the deck release handle [1] in the direction of the arrow to release the deck [2] from the host machine, and move the handle all the way to the right.

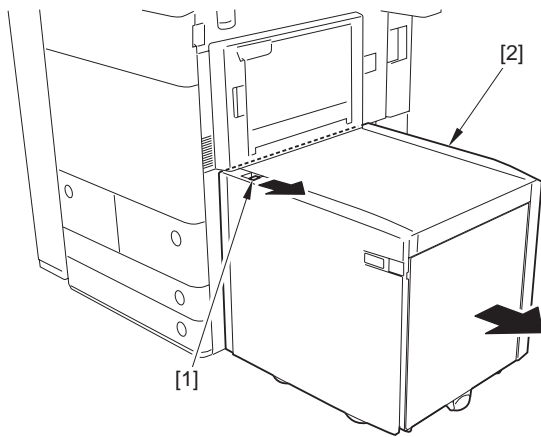

- 2) Insert a screwdriver etc. from the hole of plate [1] and push the left Release Lever [2] of the compartment downward.

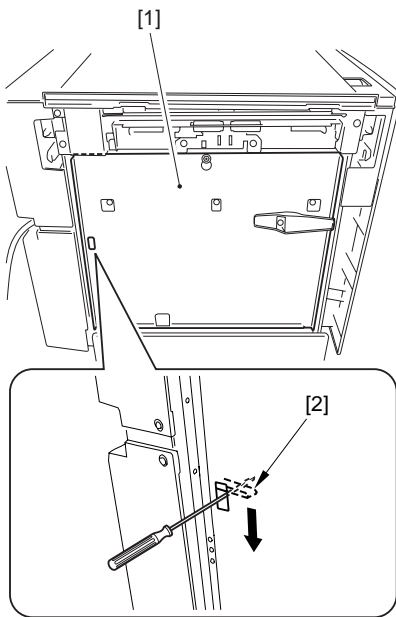

- 3) Fit a screwdriver into the hole [1] found in the rear cover to open the compartment.

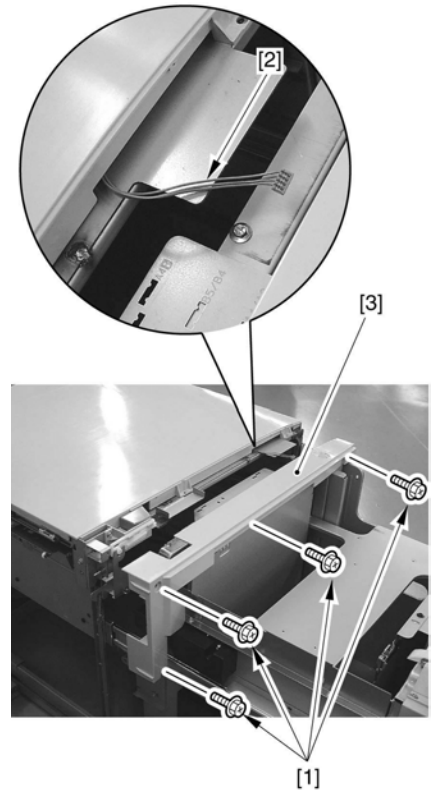

Note:
 To mount the upper front cover, take care not to trap the cable or leave the connectors disconnected.

4.5.4.2 Removing the Open Switch PCB

- 1) Remove the 2 screws [1], and detach the open switch PCB [2].

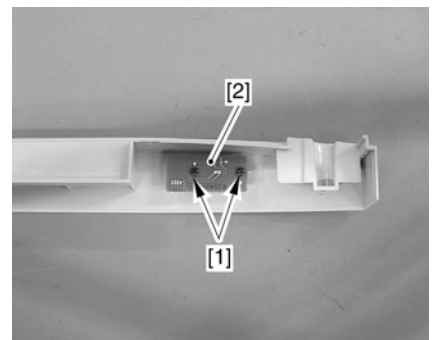

4.5.5 Environmental Sensor

4.5.5.1 Preparation for Removing the Environment Sensor

- 1) Free the machine from its host machine.
- 2) Remove the right cover. (page 4-4)Reference [Removing the Right Cover]

4.5.5.2 Removing the Environment Sensor

- 1) Remove the environment sensor [4] and the sensor plate [5].
 - 1 connector [1]
 - 1 wire saddle [2]
 - 1 screw [3]

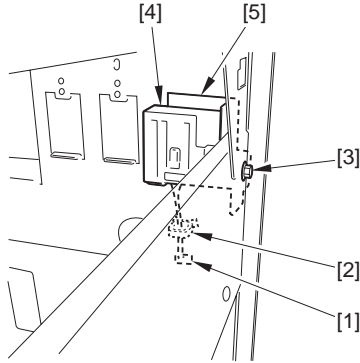

F-4-84

- 2) Remove the environment sensor [3].
 - 1 screw [1]
 - 1 connector [2]

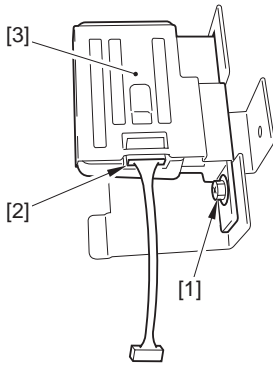

F-4-85

4.5.6 DC Power Supply PCB

4.5.6.1 Preparation for Removing the DC Power Supply PCB

- 1) Free the machine from its host machine.
- 2) Remove the rear cover. (page 4-3)Reference [Removing the Rear Cover]

4.5.6.2 Removing the DC Power Supply PCB

- 1) Remove the DC power supply PCB [4].
 - 3 connectors [1]
 - 3 screws [2]
 - 4 card spacers [3]

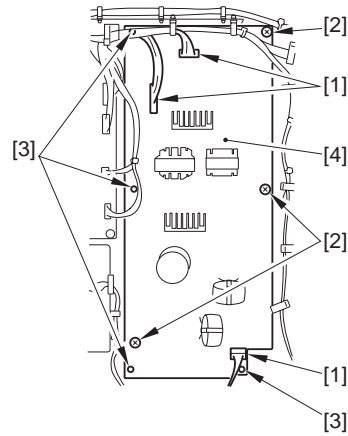

F-4-86

4.5.7 Deck Heater

4.5.7.1 Preparation for Removing the Cassette Heater

- 1) Free the machine from its host machine.
- 2) Remove the rear cover. (page 4-3)Reference [Removing the Rear Cover]
- 3) Remove the upper cover. (page 4-4)Reference [Removing the Upper Cover]

4.5.7.2 Removing the Cassette Heater

- 1) Remove each cassette heater [4] from the back of the machine.
 - 1 connector [1] each
 - 3 cable clamps [2]
 - 2 screws [3] each

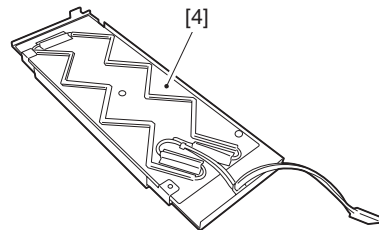
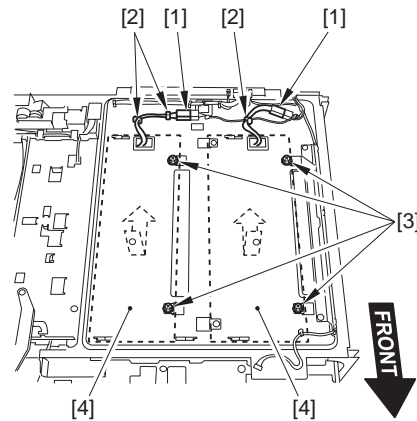

F-4-87

4.5.8 Air Heater

4.5.8.1 Preparation for Removing the Air Heater

- 1) Remove the compartment. (page 4-2)Reference [Removing the Compartment]
- 2) Remove the side guide plate (rear).
 - 2-1) Remove 2 screws [1], and 2 coin screws [2].
 - 2-2) Remove the screw [3], and detach the fixing [4].

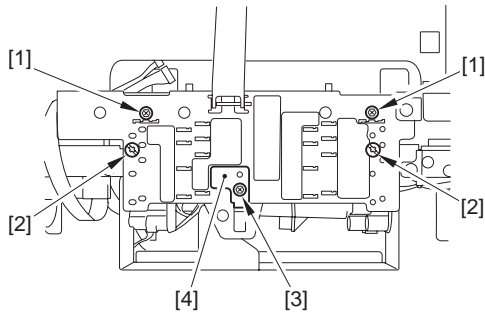

F-4-88

2-3) Disconnect the 5 connectors [1], and remove the 3 cable clamps [2].

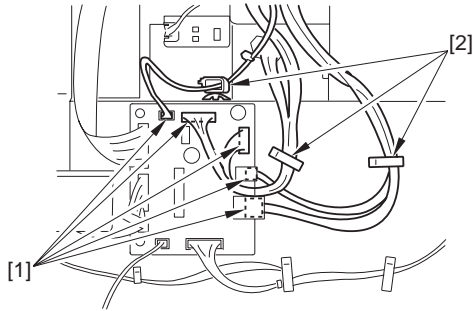

F-4-89

2-4) Move the side guide plate (rear) [1] toward the front to detach.

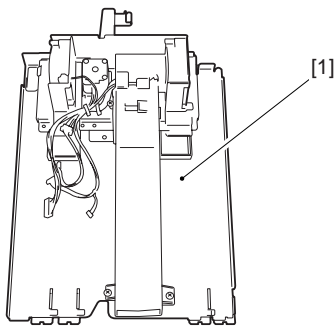

F-4-90

3) Remove the duct [6].
 - 1 screws [1]
 - 2 step screws [2]
 - 1 cable clamp [3]
 - 1 connector [4]
 - 2 cable guides [5]

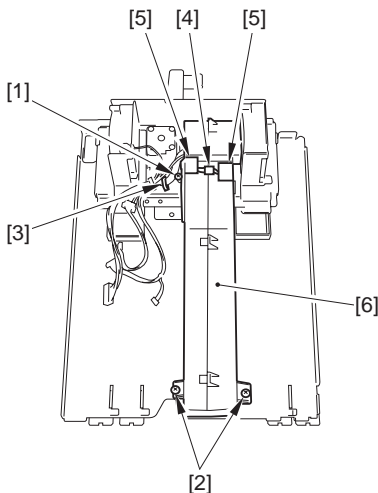

F-4-91

4.5.8.2 Removing the Air Heater

1) Remove the 3 screws [1], and open the duct [2].

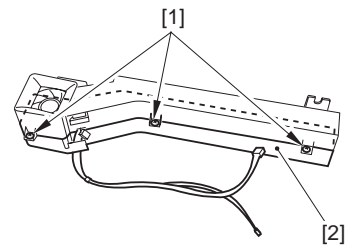

F-4-92

2) Remove the air heater [1].

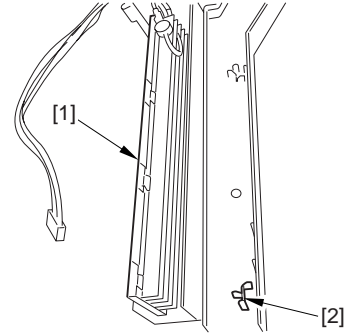

F-4-93

Note:
 When mounting the air heater, be sure to match the protrusion [1] of the air heater and the model receiving side [2].

Chapter 5 Maintenance

Contents

5.1 Maintenance and Inspection.....	5-1
5.1.1 Periodically Replaced Parts	5-1
5.1.1.1 Periodically Replaced Parts.....	5-1
5.1.2 Durables	5-1
5.1.2.1 Consumables and Durables	5-1
5.1.3 Periodical Servicing	5-1
5.1.3.1 Scheduled Servicing.....	5-1
5.2 Adjustment	5-1
5.2.1 Basic Adjustment	5-1
5.2.1.1 Position of the Front Cover	5-1
5.2.1.2 Adjusting the Registration.....	5-1
5.2.1.3 Adjusting the Position of the wheel	5-2
5.2.1.4 Adjusting the Pressure of the Deck Separation Roller.....	5-3
5.2.1.5 Position of the Deck Pickup Roller Release Solenoid	5-3
5.2.1.6 Orientation of the Pickup Roller	5-3
5.2.1.7 Orientation of the Feed Roller.....	5-3
5.2.2 Adjustment at Time of Parts Replacement	5-4
5.2.2.1 Routing the Lifter Cable.....	5-4
5.3 Outline of Electrical Components	5-5
5.3.1 Clutches/Solenoids.....	5-5
5.3.2 Motors/Fans	5-6
5.3.3 Sensors/Switches.....	5-7
5.3.4 Heaters/Others.....	5-8
5.3.5 PCBs	5-9
5.4 Variable Resistors (VR), Light-Emitting Diodes (LED), and Check Pins by PCB.....	5-10
5.4.1 Deck controller PCB	5-10
5.4.2 Box driver PCB.....	5-10

5.1 Maintenance and Inspection

5.1.1 Periodically Replaced Parts

5.1.1.1 Periodically Replaced Parts

The machine does not have parts that require periodical replacement.



A periodically replaced part is one that must be replaced on a periodical basis to ensure a specific level of machine performance; once it fails, it can affect machine functions considerably regardless of its external appearance. If possible, schedule the replacement to coincide with scheduled servicing.

5.1.2 Durables

5.1.2.1 Consumables and Durables

Some parts of the machine may require replacement once or more during the period of machine warranty because of deterioration or damage. Replace them when they fail.

T-5-1

No.	Part name	Part number	Q'ty	Life (sheets)	Remarks
1	Pickup roller (front)	FF5-7829	1	500,000	the actual number of copies made
2	Pickup roller (rear)	FF5-7830	1	500,000	the actual number of copies made
3	Pickup/feed roller	FF6-1975	1	500,000	the actual number of copies made
4	Separation roller	FB2-7777	1	500,000	the actual number of copies made



These values are estimates only, and are subject to change based on future data.

5.1.3 Periodical Servicing

5.1.3.1 Scheduled Servicing

T-5-2

Location	installation	every 500,000	Remarks
Deck pull-out roller/wheel	-	Clean	
Pickup roller (front)	-	Replace	
Pickup roller (rear)	-	Replace	
Feed roller	-	Replace	
Separation roller	-	Replace	

5.2 Adjustment

5.2.1 Basic Adjustment

5.2.1.1 Position of the Front Cover

Be sure that the front cover [1] is mounted so that the gap between it and the front upper cover [2] is 3 ± 1 mm.

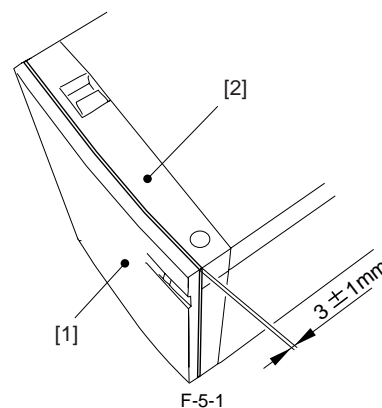

5.2.1.2 Adjusting the Registration

If the left/right registration must be adjusted (to suit the values indicated for the host machine), go through the following steps:

- 1) Perform skew correction of the host machine (adjusting the angle of the registration roller unit).
- 2) Slide out the compartment.
- 3) Loosen the 4 screws [1], and detach the front cover [2] in the front direction.

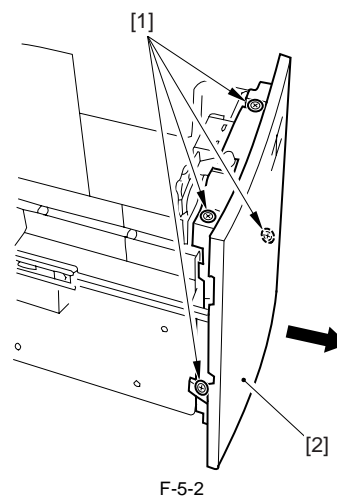

MEMO:

If you try to make adjustments without detaching the front cover, the cover (at certain positions) can prevent latching after the latch plate has been adjusted.

- 4) Adjust the position of the latch plate [1] of the compartment open solenoid using the 2 screws [2].

At this time, record the distance you have moved it (by referring to an index on the latch plate, with the index [3] serving as the best reference).

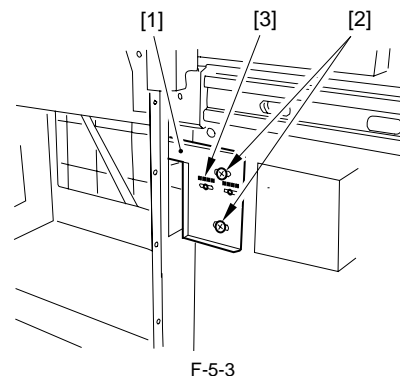

- 5) Remove the 3 screws [1], and move the right cover [2] in the front direction to detach.

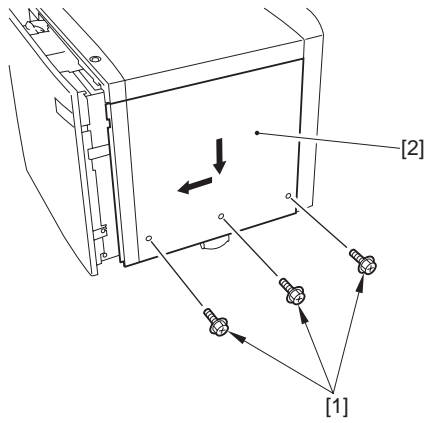

F-5-4

- 6) Close the compartment.
- 7) Adjust the position of the latch plate [1] using the 2 screws [2].
At this time, be sure to move the plate as much as you moved it in step 4). (Refer to the index [3]) on the plate).

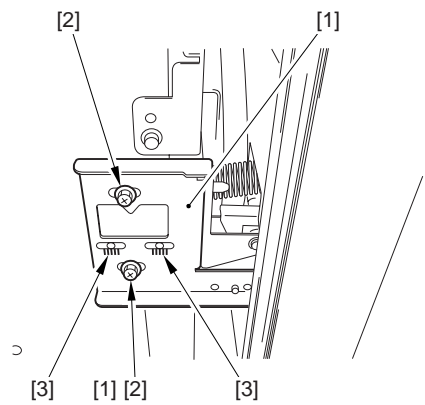

F-5-5

- 8) Adjust the position of the front cover.

5.2.1.3 Adjusting the Position of the wheel

If the compartment cannot be opened/closed smoothly, thus requiring the adjustment of the position of the roll mounted to the machine's front, perform the following:

- 1) Open the compartment.
If there is paper, remove all of it.
- 2) Loosen the 4 screws [1], and detach the machine's front cover [2] toward the front.

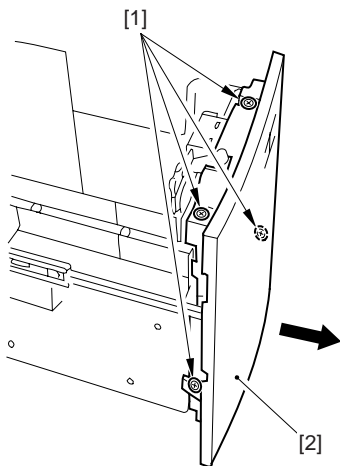

F-5-6

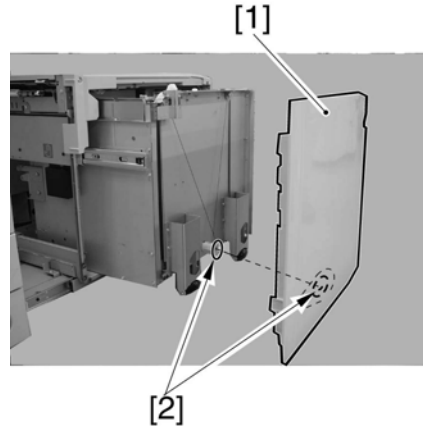

Mount the front cover [1] so that the gap to the upper front cover [2] is 3+/-1 mm.

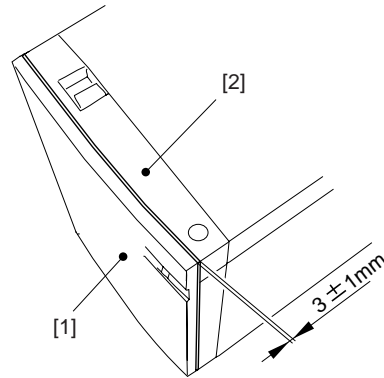

If you happen to have moved the paper level indicator drive belt found behind the front cover by hand and lost reference to its initial position as a result, or shifted the lifter, move the lifter to its lower limit, and turn the drive gear [2] in the direction that increases the white area of the display window [1] (in the direction of the arrow) until it stops before attaching the front cover (If you operate the machine without matching the paper level indicator and the lifter position, the drive system of the paper indicator can suffer damage).

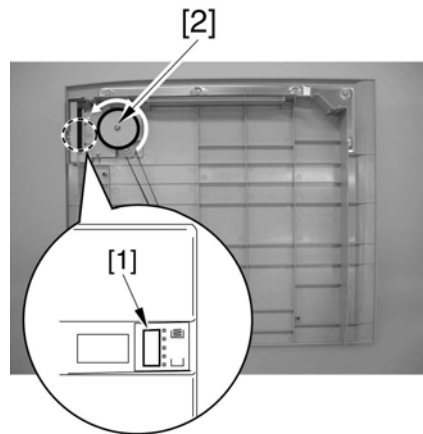

- 3) While sliding out the compartment fully, mount the roll using the roller support plate [2] and the 8 mounting screws [3] so that the roll [1] can be set 3 mm off the floor (at this time, see the indexes on the front side plate).



When mounting the front cover [1], try correctly positioning the coupling [2] of the paper level indicator.

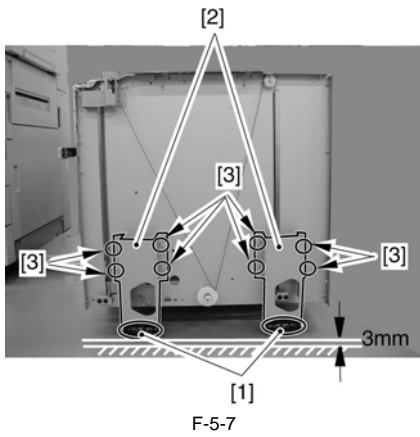

5.2.1.4 Adjusting the Pressure of the Deck Separation Roller

If pickup failure or double feeding occurs when the pickup is from the machine, change the location of the pressure spring of the deck separation roller, thereby adjusting the roller nip:

- If pickup failure occurs, move the spring in the direction of the arrow A.
- If double feeding occurs, move the spring in the direction of the arrow B.

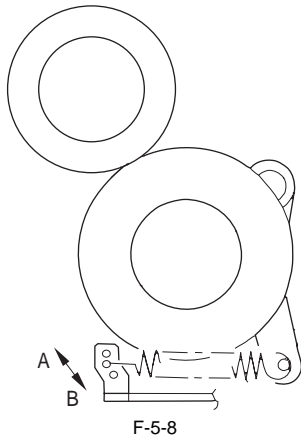

5.2.1.5 Position of the Deck Pickup Roller Release Solenoid



If the solenoid must be mounted on its own, be sure to secure it in place where it was initially found.

Before removing the deck pickup roller release solenoid [1] from its support plate, take note of the positions of the two fixing screws [2] of the solenoid with reference to the index on the support plate. Or, mark the position of the solenoid on the support plate with a scriber.

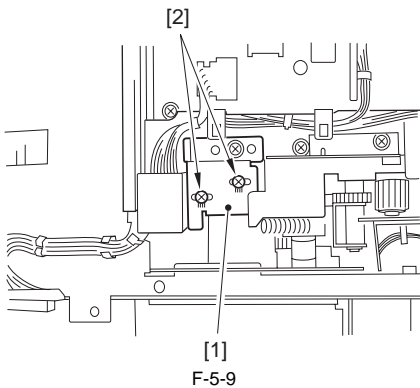

5.2.1.6 Orientation of the Pickup Roller

The pickup roller may be mounted by reversing the steps used to remove it; however, keep the following in mind:

- The pickup rollers used at the front and the rear of the machine are not in-

terchangeable.
- There are the markings (8 markings) [2] on the collar of the rear pickup roller [1].

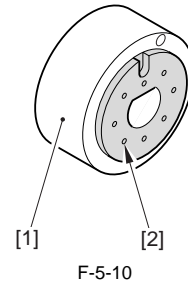

Front Pickup Roller

When mounting the pickup roller, be sure that the round marking [2] on the side of the pickup roller [1] is toward the front of the machine, and the cut-off of the collar [3] is toward the rear of the machine.

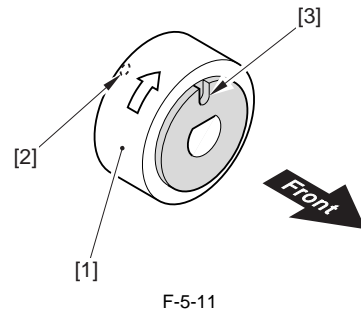

Rear Pickup Roller

When mounting the pickup roller [1], be sure that the round marking [2] on the side of the pickup roller and the cut-off of the collar [3] are toward the rear of the machine.

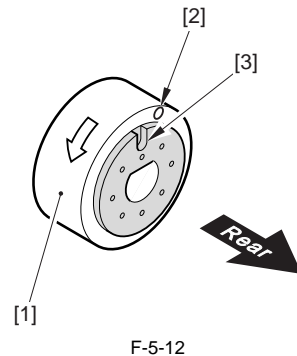

5.2.1.7 Orientation of the Feed Roller

When mounting the feed roller assembly [1] to the side paper deck pickup assembly, be sure that the belt pulley [2] is toward the front of the machine.

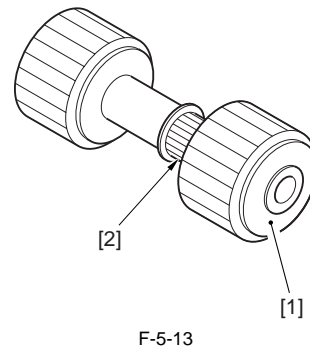

5.2.2 Adjustment at Time of Parts Replacement

5.2.2.1 Routing the Lifter Cable

- 1) Insert the hex wrench [1] into the hole of the lifter drive shaft to fix the lifter drive shaft. (To prevent rotating)
- 2) Load papers [2] (approx. 500 sheets) on the lifter to fix the lifter.
- 3) Fix the cable fixing plate [3] to the lifter by the two screws.
- 4) Hook the lifter cable on the upper pulley [4].
- 5) Hook the ball of the lifter cable on the pulley [5] of the lifter drive shaft; then, wind it along the groove of the pulley about one time. At this time, be sure that the lifter cable is taut.
- 6) In this condition, secure the pulley to the lifter drive shaft using two set screws [6].
- 7) After securing all pulleys that have been removed to the lifter drive shaft, measure the distance from the bottom plate of the compartment to the top face of the lifter, and make sure that the lifter is level.
- 8) Remove the turn-proof hexagonal wrench.

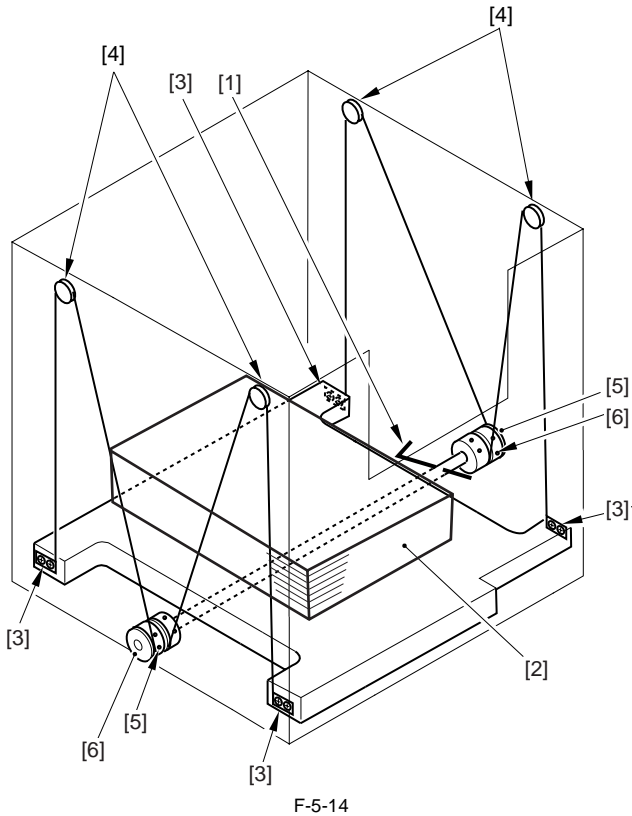

F-5-14



Ensure to remove the hexagonal wrench.

- 9) Place a sheet of paper on the Deck Tray and close the deck.
- 10) Turn ON the power of the Host Machine and wait until the Lifter is brought up and stopped.
- 11) Turn OFF the power of the Host Machine.
- 12) Push the Release Lever to release this equipment from the Host Machine, and then move it all the way to the right.

- 13) Insert a screwdriver etc. from the hole of plate [1] and push the left Release Lever [2] of the compartment downward.

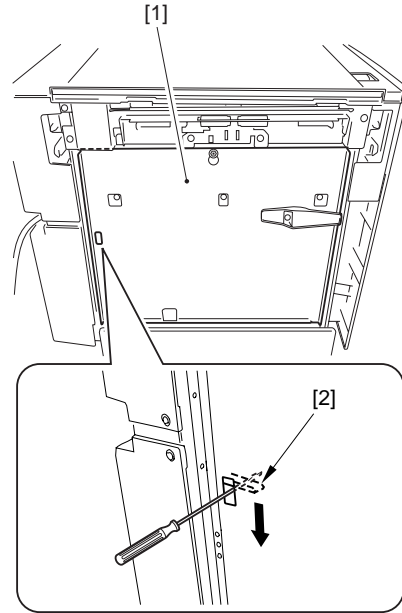

F-5-15

- 14) Put a screwdriver to the hole [1] on the Rear Cover to open the deck.

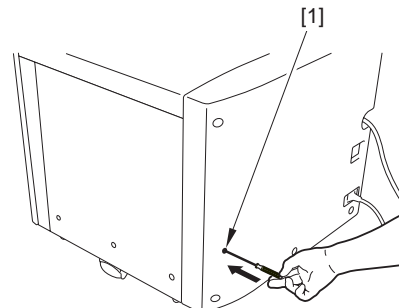

F-5-16

MEMO:

If the deck fails to be open, perform step 13) and 14) in the reverse order.

- 15) Measure the height from the Pre-Separation Plate [2] to the top of the Lifter [1] at 2 points (front and rear) and check that the Lifter [1] is positioned parallel to the Pre-Separation Plate [2]. In the case of serious disconformable, start all over again from step 1).

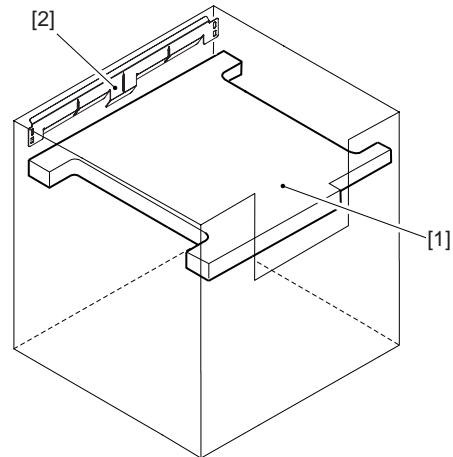

F-5-17

5.3 Outline of Electrical Components

5.3.1 Clutches/Solenoids

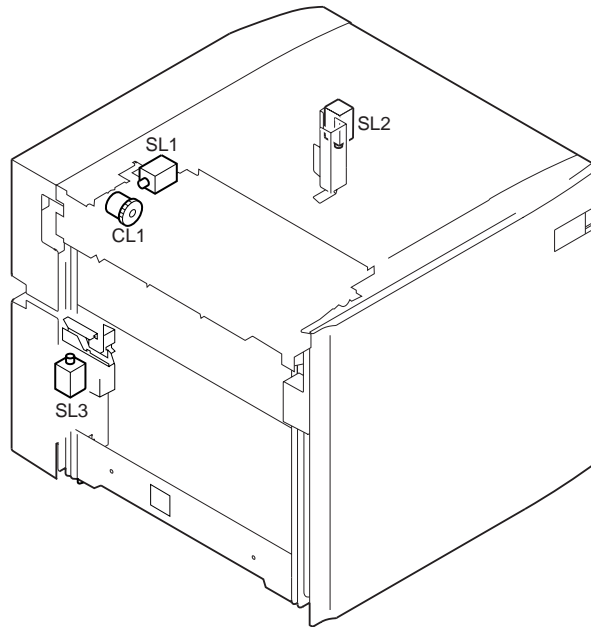

F-5-18
T-5-3

Ref.	Name	Parts number	Deck Controller PCB
CL1	Deck pickup clutch	FH6-5043	J09
SL1	Deck pickup roller release solenoid	FK2-0126	J09
SL2	Compartment open solenoid (right)	FK2-0127	J13
SL3	Compartment open solenoid (left)	FK2-0127	J13

5.3.2 Motors/Fans

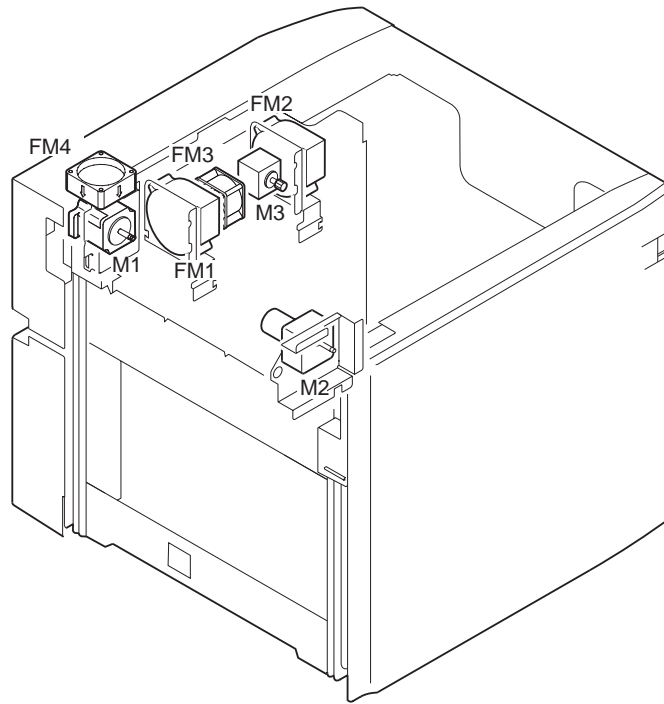
F-5-19
T-5-4

Ref.	Name	Parts number	F>MISC-P>MTR	Error	Box Driver PCB	Deck Controller PCB
M1	Deck pickup motor	FK2-1715	34		-	J06
M2	Deck lifter motor	FH6-1241	27		J55/J51	J04
M3	Swing motor	FH6-1715	38	E905	J56/J52	J05
FM1	Warming fan	FH5-1091	12		J57/J52	J05
FM2	Cooling fan	FH5-1091	12		J57/J51	J04
FM3	Additional fan	FK2-2997			J57/J52	J05
FM4	Motor cooling fan	FK2-2064			-	J30

5.3.3 Sensors/Switches

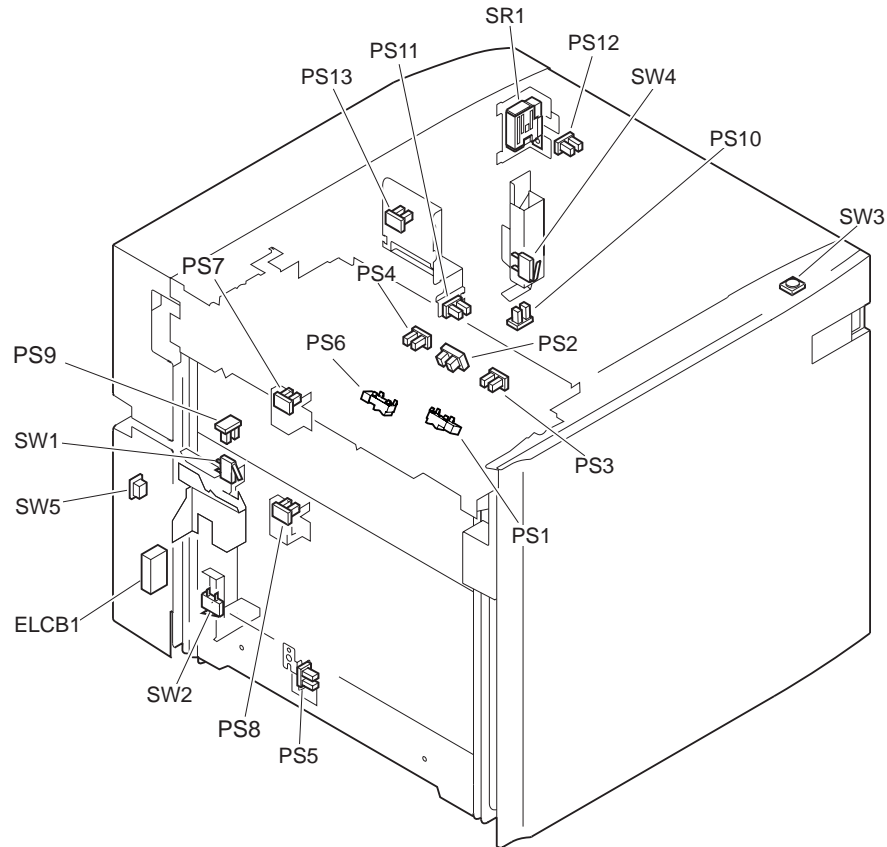
F-5-20
T-5-5

Ref.	Name	Parts number	Error	Box Driver PCB	Deck Controller PCB
PS1	Deck pickup sensor	FK2-8552			J09
PS2	Deck paper sensor	WG8-5848 [FH7-7312]			J09
PS3	Deck lifter upper limit sensor	WG8-5848 [FH7-7312]			J09
PS4	Deck lifter position sensor	WG8-5848 [FH7-7312]			J09
PS5	Deck connection sensor	WG8-5848 [FH7-7312]			J13
PS6	Deck feed sensor	FK2-8552			J09
PS7	Deck supply position sensor	WG8-5848 [FH7-7312]		J53/J51	J04
PS8	Deck paper level sensor	WG8-5848 [FH7-7312]		J53/J51	J04
PS9	Compartment open sensor (right)	WG8-5848 [FH7-7312]			J13
PS10	Compartment open sensor (left)	WG8-5848 [FH7-7312]			J13
PS11	Swing detecting sensor	WG8-5848 [FH7-7312]	E905	J61/J52	J05
PS12	Paper level sensor	WG8-5848 [FH7-7312]		J53/J52	J05
PS13	Obstacle sensor	WG8-5848 [FH7-7312]			J09
SW1	Lifter motor safety switch	WC4-5153			J08
SW2	Deck lifter lower limit detecting switch	WC4-0153		J53/J51	J04
SW3	Compartment open switch	WC6-5013			J09
SW4	Fan safety switch	WC4-5153			J07
SW5	Cassette heater switch	WC1-5179			J21
SR1	Environmental sensor	WP2-5200			J13
ELCB1	Leakage breaker	FH7-7625			

5.3.4 Heaters/Others

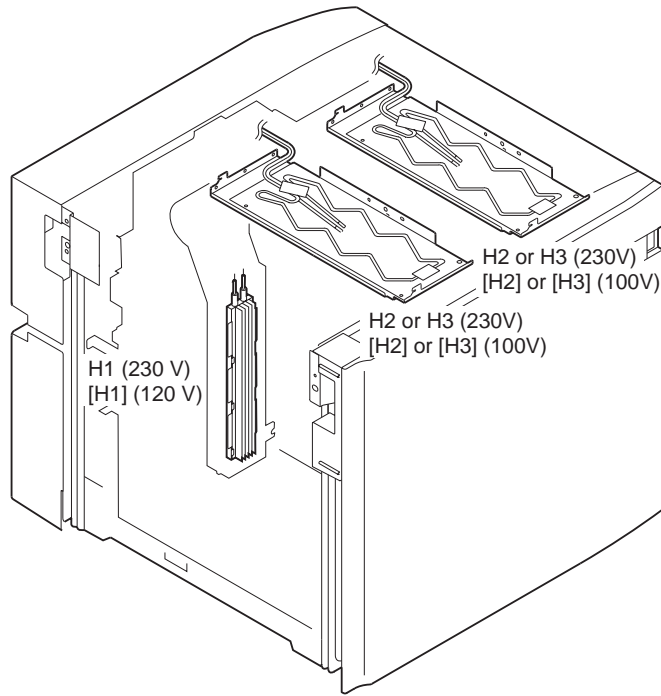

F-5-21
T-5-6

Ref.	Name	Parts number	F-MISCp>IO	Error	Box Driver PCB	Deck Controller PCB
H1	Air Heater (230 V)	FK2-2995	54	E906	J54, J59 /J58	J03
[H1]	Air Heater (120 V)	FK2-2993				
H2, H3	Cassette Heater (230 V)	FH7-4585	55		-	J14, J21
[H2], [H3]	Cassette Heater (100 V)	FH7-4584				

5.3.5 PCBs

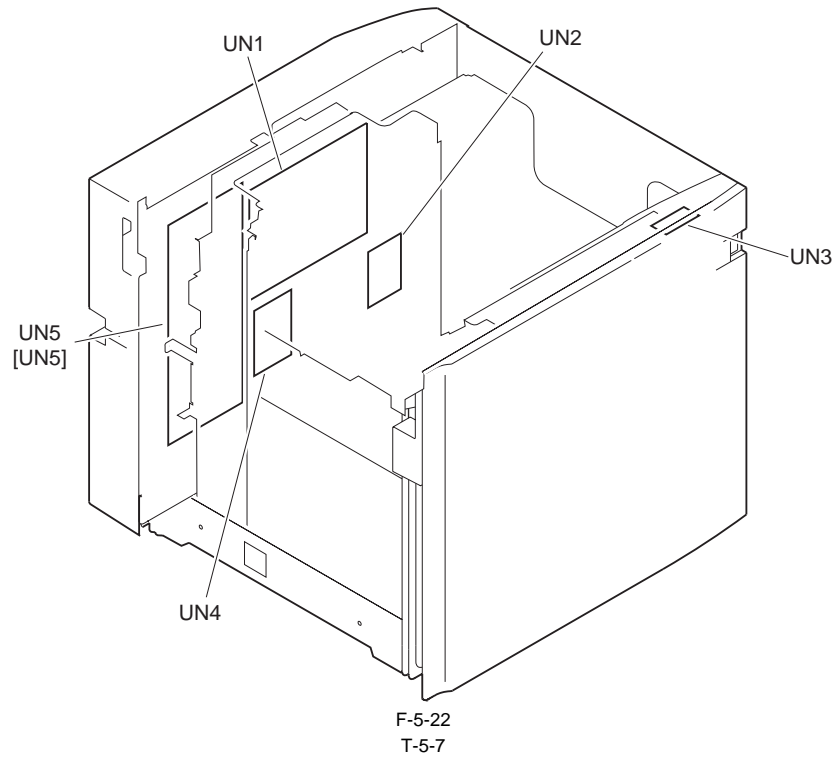

Ref.	Name	Parts number
UN1	Deck Controller PCB	FM2-7595
UN2	Box Driver PCB	FM2-7596
UN3	Open switch PCB	FM2-0856
UN4	Noise filter PCB	FK2-0816
UN5	DC Power Supply PCB (200 V/230 V)	FK2-2806
[UN5]	DC Power Supply PCB (100 V/120 V)	FK2-2805

5.4 Variable Resistors (VR), Light-Emitting Diodes (LED), and Check Pins by PCB

5.4.1 Deck controller PCB

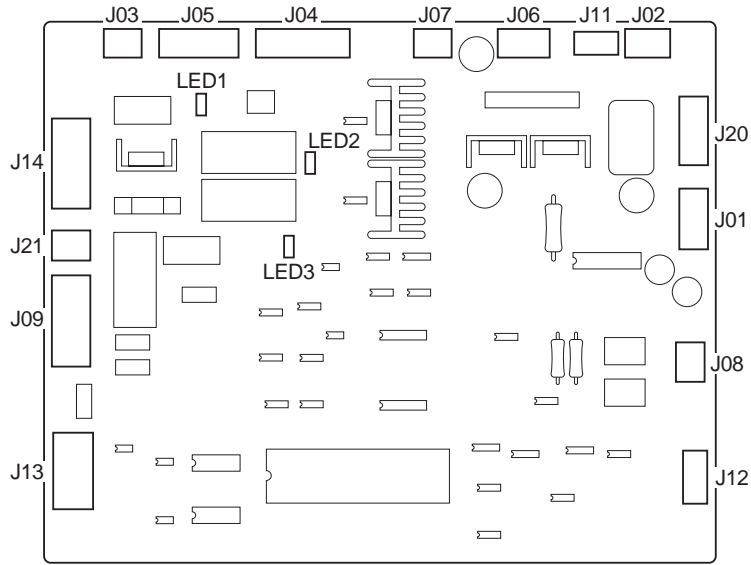

F-5-23
T-5-8

Ref.	ON	OFF	Remarks
LED1	Air heater supplied with power	Air heater not supplied with power	-
LED2	Air heater relay ON	Air heater relay OFF (air heater overheating detection)	-
LED3	Cassette heater control signal ON	Cassette heater control signal OFF	Indicates control signals that are normally ON. Does not have a relationship to the cassette heater switch and, therefore, does not indicate the supply status of the heater.

5.4.2 Box driver PCB

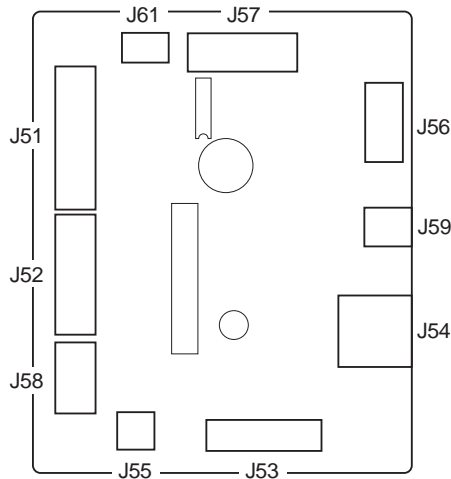

F-5-24

Chapter 6 Error Code

Contents

6.1 Service Error Code.....	6-1
6.1.1 Outline.....	6-1

6.1 Service Error Code

6.1.1 Outline

Refer to service manual of host machine.

Appendix

1 General Timing Chart

General Timing Chart

Sequence of Pickup Operations (from deck; A4, 2 sheets, continuous)

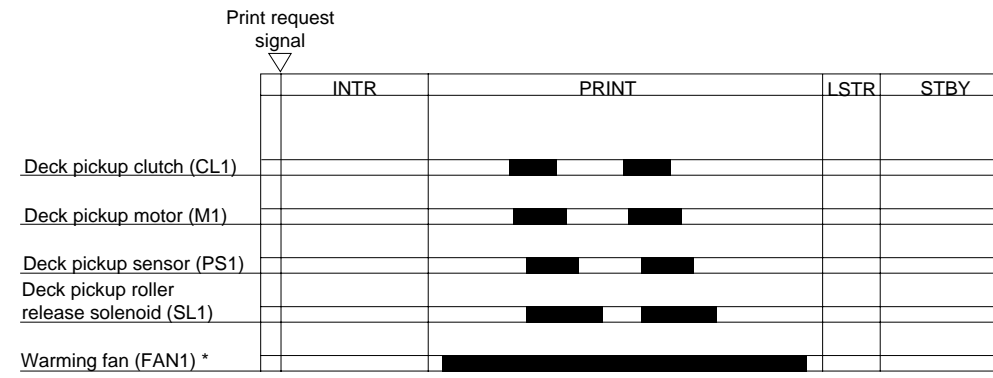

* In case the paper interval is more than 3 sec, the warming fan stops.

F-1-1

Sequence of Pickup Operations (from deck; A3, 2 sheets, continuous)

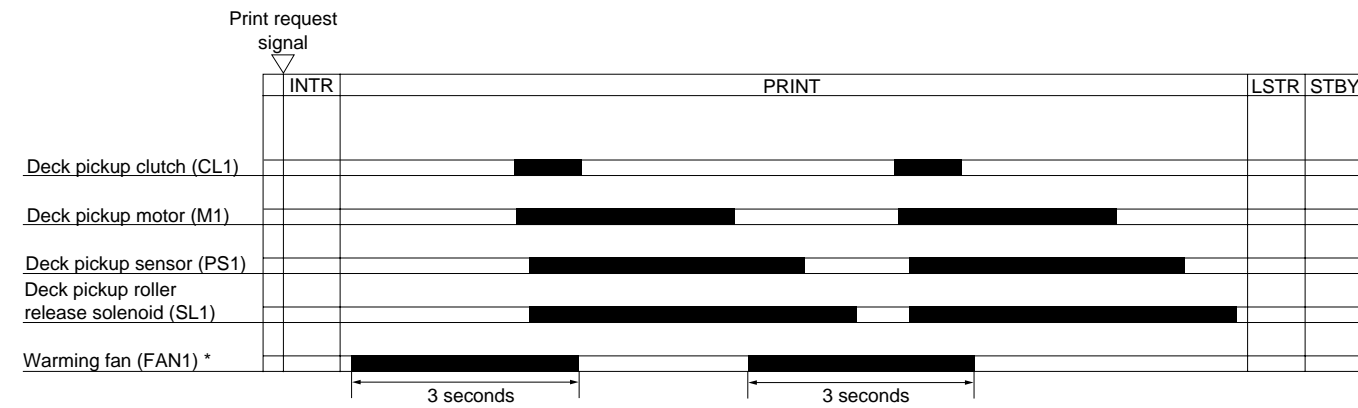

* The warming fan may not be activated depending on the paper type and the environment.

F-1-2

2 General Circuit Diagram
 General Circuit Diagram
 General Circuit Diagram (1/3)

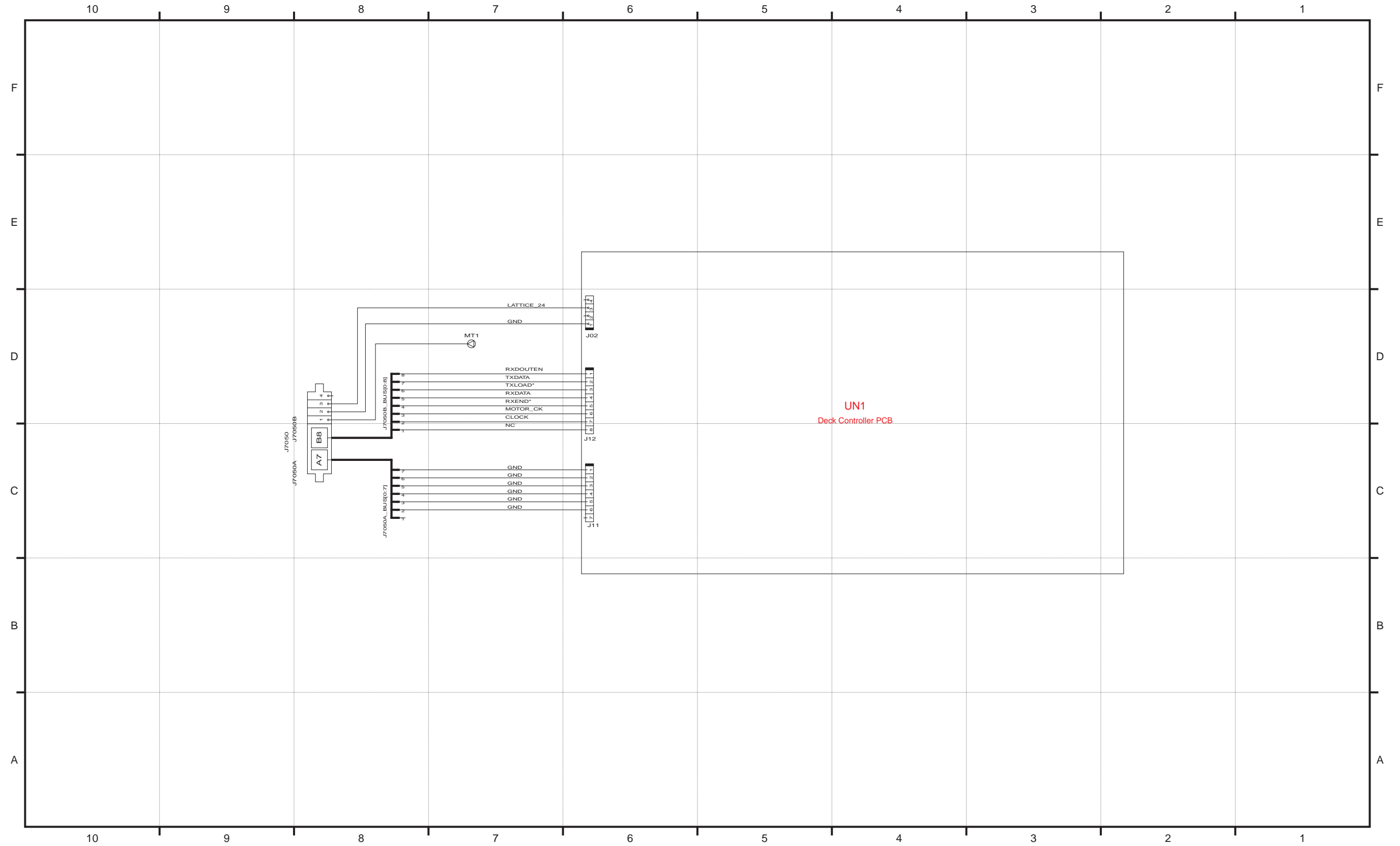

F-2-1

P.1

General Circuit Diagram (2/3)

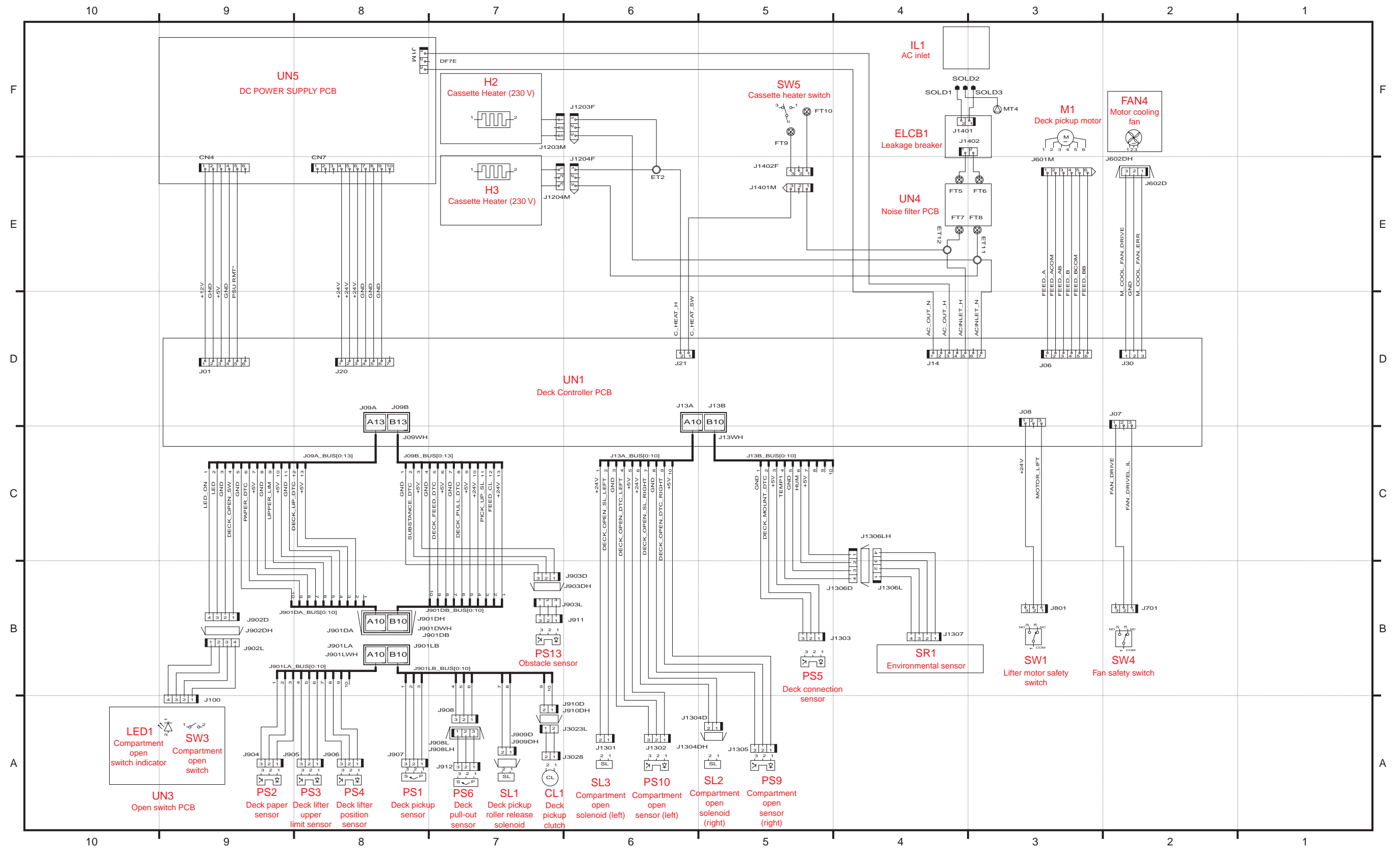

F-2-2

P.2

General Circuit Diagram (3/3)

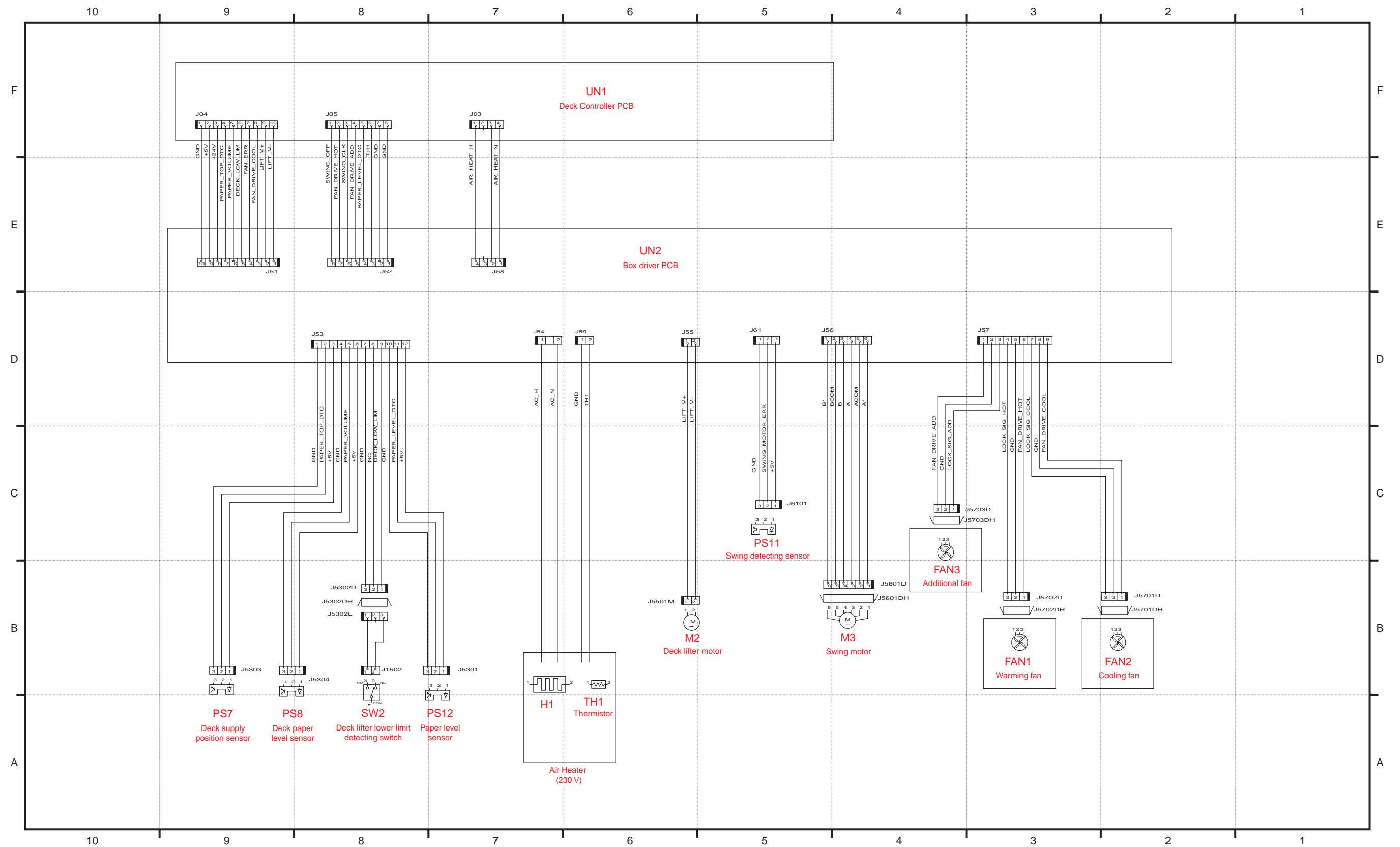

F-2-3

P.3

Sep 30 2009

Canon