

PARTS CATALOG

imagePROGRAF iPF8300/8300S/ 8100/8000S/8000



Canon

**March 9, 2011
Rev. 0**

PREFACE

This Parts Catalog contains listings of parts used

Diagrams are provided with the listings to aid the service technician in identifying clearly, the item to be ordered.

Whenever ordering parts, consult this Parts Catalog for all of the information pertaining to each item. Be sure to include, in the Parts Request, the full item description, the item part number, and the quantity.

COPYRIGHT (C) 1999 CANON INC.

Use of this manual should be strictly supervised to avoid disclosure of confidential information.

Contents

NUMERICAL INDEX

iPF8300/8300S/8100/8000S/8000(Numerical Index) 1-1

iPF8300/8300S/8100/8000S/8000(Parts Catalog)

01	PRINTER & ACCESSORIES	2-1
02	COVERS (1)	2-4
03	COVERS (2)	2-6
04	ELECTRICAL PART	2-9
05	INK TANK & PURGE UNIT	2-11
06	CARRIAGE UNIT	2-13
07	FEED MOTOR ASS'Y	2-17
08	AIR FLOW FAN UNIT	2-20
09	PINCH ROLLER UNIT	2-22
10	PLATEN & FEED ROLLER	2-23
11	LINEAR SCALE	2-26
12	TOOL	2-27
R1	STAND UNIT	2-28
R2	MEDIA TAKE-UP UNIT	2-30
ZZA	MECHANICAL STANDARD PARTS(HOW TO USE)	2-33
ZZB	MECHANICAL STANDARD PARTS(SCREWS)	2-34
ZZC	MECHANICAL STANDARD PARTS(BOLTS)	2-41
ZZD	MECHANICAL STANDARD PARTS(NUTS)	2-42
ZZE	MECHANICAL STANDARD PARTS(RETAINING RINGS)	2-43

NUMERICAL INDEX

iPF8300/8300S/8100/8000S/8000(Numerical Index)

PARTS NUMBER	FIGURE & KEY NO.	PARTS NUMBER	FIGURE & KEY NO.	PARTS NUMBER	FIGURE & KEY NO.
CK-0551-020	12 - 2	QC1-7141-000	07 - 21	QC2-3137-000	06 - 43
CK-0562-000	12 - 3	QC1-7143-000	03 - 19	QC2-3138-000	06 - 15
FA3-8727-000	07 - 27	QC1-7156-000	06 - 20	QC2-4036-000	06 - 31
FA3-8727-000	10 - 20	QC1-7237-000	08 - 7	QC2-4064-040	02 - 9
FB1-0733-000	01 - 9	QC1-7278-000	03 - 9	QC2-4116-000	R1 - 9
FH2-7092-020	01 - 17	QC1-7303-000	06 - 42	QC2-4136-000	07 - 15
FH7-5489-050	07 - 19	QC1-7399-000	03 - 23	QC2-4350-000	R1 - 2
FK2-2416-000	04 - 11	QC1-9198-000	08 - 10	QC2-4351-000	R1 - 3
FS5-1189-000	07 - 33	QC2-0653-000	06 - 16	QC2-6025-000	R1 - 7
NPN	01 -	QC2-0659-050	06 - 8	QC2-6626-000	R1 - 1
NPN	01 - 1	QC2-0660-050	06 - 9	QC2-6657-020	03 - 3
NPN	01 - 2	QC2-0661-000	06 - 10	QC2-6658-000	02 - 1
NPN	01 - 2	QC2-0710-000	06 - 28	QC2-6659-000	02 - 2
NPN	01 - 2	QC2-2078-000	06 - 12	QC2-6660-000	03 - 7
NPN	01 - 2	QC2-2082-000	10 - 11	QC2-6679-000	02 - 17
NPN	01 - 2	QC2-2104-000	06 - 13	QC3-0169-000	01 - 9
NPN	01 - 2	QC2-2106-000	06 - 14	QC3-1731-000	R1 - 10
NPN	01 - 2	QC2-2172-000	03 - 6	QC3-1877-000	11 - 2
NPN	01 - 2	QC2-2173-000	03 - 7	QC3-2713-000	03 - 3
NPN	01 - 2	QC2-2177-000	03 - 4	QC3-2714-000	02 - 1
NPN	01 - 2	QC2-2178-020	03 - 3	QC3-2715-000	02 - 2
NPN	01 - 2	QC2-2179-000	03 - 14	QC3-2716-000	03 - 7
NPN	01 - 2	QC2-2180-000	03 - 15	QC3-2769-000	06 - 13
NPN	02 -	QC2-2181-000	02 - 5	QC3-2770-000	06 - 14
NPN	03 -	QC2-2183-000	02 - 6	QC3-3648-000	03 - 16
NPN	04 -	QC2-2191-000	02 - 3	QC3-3653-000	07 - 14
NPN	05 -	QC2-2192-000	02 - 4	QE1-1048-000	09 - 4
NPN	06 -	QC2-2195-000	07 - 28	QE1-1063-000	07 - 17
NPN	07 -	QC2-2198-000	02 - 7	QE1-1270-000	06 - 44
NPN	08 -	QC2-2199-000	02 - 8	QE1-1495-000	R2 - 27
NPN	09 -	QC2-2202-030	02 - 10	QE1-2304-000	R2 - 28
NPN	10 -	QC2-2224-000	01 - 8	QE1-2334-000	01 - 18
NPN	11 -	QC2-2354-000	10 - 19	QE1-2691-000	06 - 46
NPN	12 -	QC2-2355-000	10 - 7	QH2-2732-000	01 - 15
NPN	R1 -	QC2-2356-000	10 - 17	QK1-1387-000	08 - 11
NPN	R2 -	QC2-2364-000	06 - 23	QK1-1392-000	01 - 13
QC1-6847-000	07 - 6	QC2-2365-000	06 - 24	QK1-1393-000	01 - 12
QC1-6921-000	10 - 10	QC2-2366-000	06 - 25	QK1-1394-000	01 - 11
QC1-6924-000	03 - 8	QC2-2399-000	R2 - 5	QK1-1395-000	01 - 14
QC1-6925-000	03 - 11	QC2-2401-000	R2 - 6	QK1-1396-010	01 - 16
QC1-6926-000	03 - 12	QC2-2402-000	R2 - 7	QK1-2091-000	06 - 39
QC1-6927-000	03 - 13	QC2-2403-000	R2 - 8	QK1-2758-000	06 - 39
QC1-6930-000	02 - 1	QC2-2404-000	R2 - 9	QK1-2868-000	06 - 48
QC1-6931-000	02 - 2	QC2-2408-000	R2 - 10	QK1-2908-000	R2 - 1
QC1-6999-000	09 - 3	QC2-2409-000	R2 - 11	QK1-2912-000	04 - 3
QC1-7034-000	10 - 16	QC2-2410-000	R2 - 12	QK1-2983-000	06 - 40
QC1-7043-000	10 - 15	QC2-2412-000	R2 - 13	QK1-2984-000	06 - 41
QC1-7067-000	07 - 24	QC2-2413-000	R2 - 32	QK1-2985-000	06 - 32
QC1-7068-000	07 - 16	QC2-2417-000	R2 - 33	QL2-1104-000	06 - 33
QC1-7092-000	07 - 14	QC2-2434-000	R2 - 31	QL2-1114-000	06 - 34
QC1-7137-000	01 - 10	QC2-3113-000	03 - 20	QL2-1125-000	06 - 50
QC1-7138-000	03 - 18	QC2-3114-000	03 - 21	QL2-1650-000	08 - 3

NUMERICAL INDEX

iPF8300/8300S/8100/8000S/8000(Numerical Index)

PARTS NUMBER	FIGURE & KEY NO.	PARTS NUMBER	FIGURE & KEY NO.	PARTS NUMBER	FIGURE & KEY NO.
QL2-1659-000	10 - 4	QM3-0969-000	03 - 2	QM3-3033-030	03 - 1
QL2-1660-000	10 - 5	QM3-0970-000	03 - 2	QM3-3069-000	08 - 5
QL2-1663-000	08 - 13	QM3-0979-000	06 - 29	QM3-3072-000	05 - 2
QL2-1666-010	01 - 3	QM3-0980-000	06 - 37	QM3-3073-000	05 - 3
QL2-1668-000	03 - 16	QM3-0983-000	04 - 5	QM3-3080-000	05 - 2
QL2-1676-000	R2 - 25	QM3-1004-010	05 - 1	QM3-3081-000	05 - 3
QL2-1692-000	02 - 12	QM3-1005-000	05 - 2	QM3-3091-020	06 - 1
QL2-1697-000	02 - 13	QM3-1006-000	05 - 3	QM3-3093-000	06 - 7
QL2-2089-000	10 - 1	QM3-1012-000	08 - 5	QM3-3106-000	06 - 29
QL2-2094-000	R2 - 26	QM3-1017-000	06 - 3	QM3-3107-000	06 - 37
QL2-2095-000	07 - 4	QM3-1018-000	06 - 4	QM3-3108-000	03 - 2
QL2-2101-000	03 - 4	QM3-1020-000	06 - 45	QM3-3109-000	03 - 2
QL2-2108-000	08 - 4	QM3-1024-000	07 - 22	QM3-3112-000	06 - 36
QL2-2109-000	10 - 6	QM3-1025-000	07 - 32	QM3-3113-000	04 - 10
QL2-2110-000	08 - 1	QM3-1026-000	07 - 25	QM3-3121-000	06 - 37
QL2-2114-000	08 - 2	QM3-1027-000	07 - 26	QM3-3131-000	04 - 1
QL2-2326-000	R1 - 11	QM3-1031-000	02 - 14	QM3-3138-000	06 - 21
QL2-2327-000	R1 - 4	QM3-1033-020	05 - 6	QM3-3139-000	06 - 29
QL2-2442-000	06 - 34	QM3-1034-020	05 - 5	QM3-3153-000	04 - 1
QL2-2443-000	06 - 33	QM3-1038-000	08 - 9	QM3-3165-000	03 - 2
QL2-2782-000	10 - 8	QM3-1044-010	06 - 22	QM3-3166-000	03 - 2
QL2-2783-000	10 - 3	QM3-1047-000	04 - 4	QM3-3187-000	04 - 1
QL2-2784-000	10 - 2	QM3-1055-000	05 - 4	QM3-3202-000	04 - 1
QL2-2823-000	08 - 12	QM3-1056-000	08 - 6	QM3-3267-010	01 - 20
QL2-2916-000	01 - 21	QM3-1091-000	R2 - 34	QM3-3268-010	01 - 23
QL2-3143-000	R2 - 19	QM3-1092-000	R2 - 4	QM3-3269-010	01 - 22
QL2-3145-000	R2 - 20	QM3-1093-000	R2 - 15	QM3-3359-020	06 - 1
QL2-3146-000	R2 - 21	QM3-1095-000	R2 - 18	QM3-4829-000	09 - 2
QL2-3147-000	R2 - 22	QM3-1106-000	07 - 7	QM3-4843-000	08 - 8
QL2-3148-000	R2 - 23	QM3-1108-000	R2 - 16	QM3-4876-010	01 - 24
QL2-3149-000	R2 - 24	QM3-1109-000	R2 - 17	QM3-5254-000	04 - 8
QL2-3279-000	10 - 1	QM3-1117-000	01 - 6	QM3-6505-000	02 - 14
QL2-3385-000	10 - 23	QM3-1149-000	04 - 9	QM3-6508-000	03 - 1
QL2-3402-000	02 - 11	QM3-1419-000	08 - 8	QM3-6509-010	03 - 2
QM1-0662-000	06 - 47	QM3-1995-060	06 - 7	QM3-6510-010	03 - 2
QM2-2470-040	01 - 5	QM3-1996-000	03 - 17	QM3-6511-000	02 - 15
QM2-2475-000	01 - 7	QM3-1999-010	10 - 12	QM3-6512-000	05 - 2
QM2-2476-090	01 - 4	QM3-2003-000	10 - 22	QM3-6513-000	05 - 3
QM2-2495-010	03 - 5	QM3-2004-040	06 - 1	QM3-7018-000	05 - 1
QM2-2502-000	07 - 3	QM3-2005-020	06 - 6	QM3-7025-000	08 - 9
QM2-2511-000	07 - 18	QM3-2007-000	02 - 15	QM3-7026-000	10 - 12
QM2-2526-000	07 - 13	QM3-2008-030	03 - 1	QM3-7030-000	06 - 1
QM2-2528-010	10 - 9	QM3-2011-000	R2 - 30	QM3-7032-000	07 - 31
QM2-2572-000	06 - 49	QM3-2016-000	07 - 31	QM3-7033-000	06 - 7
QM2-2596-050	09 - 1	QM3-2022-000	R1 - 5	QM3-7034-000	07 - 13
QM2-2597-000	09 - 2	QM3-2023-000	R1 - 5	QM3-7036-000	04 - 4
QM2-3421-010	06 - 36	QM3-2064-000	08 - 12	QM3-7042-000	07 - 32
QM2-3426-000	06 - 21	QM3-2854-000	R1 - 8	QM3-7700-000	10 - 24
QM3-0541-000	06 - 17	QM3-3026-000	02 - 14	QM3-7701-000	10 - 25
QM3-0560-000	06 - 18	QM3-3029-010	04 - 8	QM3-7702-000	10 - 26
QM3-0584-000	06 - 2	QM3-3031-000	02 - 15	QM3-7703-000	10 - 27
QM3-0957-000	04 - 1	QM3-3032-000	02 - 15	QM3-9934-000	03 - 2

NUMERICAL INDEX

iPF8300/8300S/8100/8000S/8000(Numerical Index)

PARTS NUMBER	FIGURE & KEY NO.	PARTS NUMBER	FIGURE & KEY NO.	PARTS NUMBER	FIGURE & KEY NO
QM3-9935-000	03 - 2	XB1-2300-607	05 - 501		
QM3-9936-000	02 - 15	XB1-2300-806	06 - 503		
QM3-9937-000	05 - 2	XB1-2400-606	04 - 501		
QM3-9938-000	05 - 3	XB1-2400-606	06 - 505		
QM3-9943-000	06 - 1	XB1-2400-806	03 - 501		
QM3-9945-000	03 - 1	XB2-8401-009	07 - 501		
QU1-0082-000	07 - 8	XB4-5300-806	06 - 504		
QU1-0083-000	07 - 9	XB4-5400-806	07 - 503		
QU1-0084-000	07 - 11	XB4-7300-807	R2 - 501		
QU1-0130-000	06 - 26	XB4-7300-809	06 - 502		
QU1-0131-000	06 - 27	XB4-7301-009	06 - 506		
QU1-1004-000	06 - 38	XB4-7401-009	06 - 501		
QU1-2005-000	06 - 5	XB4-7402-509	08 - 502		
QU1-2006-000	06 - 19	XB4-7404-009	08 - 501		
QU1-2169-000	11 - 1	XB5-2400-809	05 - 502		
QU1-2170-000	07 - 1	XD1-1100-502	06 - 507		
QU1-2173-000	07 - 20	XD1-1108-219	09 - 502		
QU1-2175-000	06 - 35	XD2-1100-322	R2 - 503		
QU1-2185-000	03 - 10	XD2-1100-502	R2 - 502		
QU1-6016-000	07 - 10	XD2-1100-642	09 - 501		
QY9-0103-000	12 - 1	XD2-3100-152	10 - 501		
WC4-5052-000	10 - 18	XD3-2200-222	07 - 504		
WC4-5180-000	07 - 23	XF2-4117-360	07 - 12		
WG8-5624-000	06 - 30	XF2-4119-770	07 - 2		
WG8-5624-000	10 - 13	XF2-4119-790	07 - 2		
WG8-5624-000	R2 - 14	XG9-0365-000	09 - 6		
WG8-5677-000	10 - 14	XG9-0453-000	07 - 5		
WG8-5770-000	R2 - 2	XG9-0549-000	09 - 6		
WG8-5771-000	R2 - 3				
WK1-5024-000	04 - 2				
WM2-5272-000	04 - 11				
WP2-5187-000	04 - 6				
XA9-0249-000	07 - 30				
XA9-0724-000	10 - 502				
XA9-0732-000	02 - 16				
XA9-0732-000	03 - 22				
XA9-0732-000	04 - 7				
XA9-0732-000	05 - 7				
XA9-0732-000	06 - 11				
XA9-0732-000	07 - 29				
XA9-0732-000	08 - 14				
XA9-0732-000	09 - 5				
XA9-0732-000	10 - 21				
XA9-1501-000	01 - 19				
XA9-1501-000	01 - 19				
XA9-1501-000	R2 - 29				
XA9-2027-000	02 - 18				
XA9-2027-000	05 - 8				
XA9-2027-000	08 - 15				
XB1-2300-406	04 - 503				
XB1-2300-406	07 - 502				
XB1-2300-606	04 - 502				

iPF8300/8300S/8100/8000S/8000(Parts Catalog)

iPF8300

120/230V	Q51-1994-000
----------	--------------

100V	Q51-1997-000
------	--------------

iPF8300S

120/230V	Q51-2174-000
----------	--------------

100V	Q51-2177-000
------	--------------

iPF8100

120/230V	Q51-1704-000
----------	--------------

100V	Q51-1707-000
------	--------------

iPF8000S

120/230V	Q51-1684-000
----------	--------------

100V	Q51-1687-000
------	--------------

iPF8000

120/230V	Q51-1544-000
----------	--------------

100V	Q51-1547-000
------	--------------

ST-43

**Q55-2450-
000**

TU-06

**Q55-2330-
000**

Contents

01	PRINTER & ACCESSORIES	2-1
02	COVERS (1)	2-4
03	COVERS (2)	2-6
04	ELECTRICAL PART	2-9
05	INK TANK & PURGE UNIT	2-11
06	CARRIAGE UNIT	2-13
07	FEED MOTOR ASS'Y	2-17
08	AIR FLOW FAN UNIT	2-20
09	PINCH ROLLER UNIT	2-22
10	PLATEN & FEED ROLLER.....	2-23
11	LINEAR SCALE	2-26
12	TOOL	2-27
R1	STAND UNIT	2-28
R2	MEDIA TAKE-UP UNIT.....	2-30
ZZA	MECHANICAL STANDARD PARTS(HOW TO USE)	2-33
ZZB	MECHANICAL STANDARD PARTS(SCREWS).....	2-34
ZZC	MECHANICAL STANDARD PARTS(BOLTS).....	2-41
ZZD	MECHANICAL STANDARD PARTS(NUTS).....	2-42
ZZE	MECHANICAL STANDARD PARTS(RETAINING RINGS)	2-43

FIGURE 01 PRINTER & ACCESSORIES

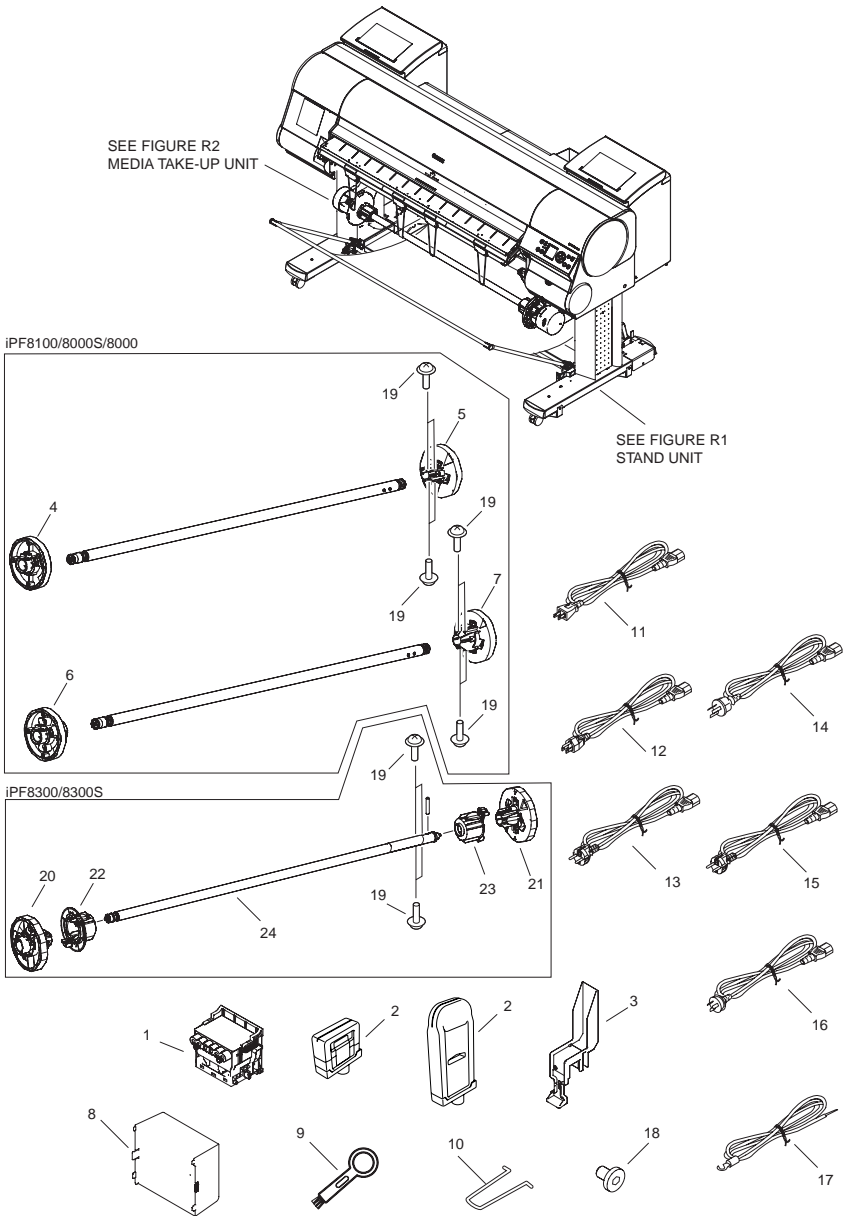

FIGURE & KEY NO.	PARTS NUMBER	R A N K	Q'TY	DESCRIPTION	SERIAL NUMBER/ REMARKS	S V C
Fig.01	NPN		RF	PRINTER & ACCESSORIES		
1	NPN		RF	PRINTHEAD		
2	NPN		RF	INK TANK (MBK)		
2	NPN		RF	INK TANK (PBK)		
2	NPN		RF	INK TANK (C)		
2	NPN		RF	INK TANK (M)		
2	NPN		RF	INK TANK (Y)		
2	NPN		RF	INK TANK (PC)		
2	NPN		RF	INK TANK (PM)		
2	NPN		RF	INK TANK (GY)		
2	NPN		RF	INK TANK (R)	iPF8300/8100/8000	
2	NPN		RF	INK TANK (G)	iPF8300/8100/8000	
2	NPN		RF	INK TANK (B)	iPF8300/8100/8000	
2	NPN		RF	INK TANK (PGY)	iPF8300/8100/8000	
3	QL2-1666-010		1	STOPPER, BELT		
4	QM2-2476-090		1	2 INCH DRIVE SPOOL UNIT LEFT	iPF8100/8000S/8000	
5	QM2-2470-040		1	2 INCH DRIVE SPOOL UNIT RIGHT	iPF8100/8000S/8000	
6	QM3-1117-000		1	3 INCH DRIVE SPOOL UNIT LEFT	iPF8100/8000S/8000	
7	QM2-2475-000		1	3 INCH DRIVE SPOOL UNIT RIGHT	iPF8100/8000S/8000	
8	QC2-2224-000		1	POCKET		
9	FB1-0733-000		1	BRUSH, CLEANER	iPF8100/8000S/8000	
9	QC3-0169-000		1	BRUSH, CLEANER	iPF8300/8300S	
10	QC1-7137-000		4	BAR, DELIVERY SUPPORT		
11	QK1-1394-000		1	CORD, POWER	100V	
12	QK1-1393-000		1	CORD, POWER	120V UL	
13	QK1-1392-000		1	CORD, POWER	230V	
14	QK1-1395-000		1	CORD, POWER	230V AUS	
15	QH2-2732-000		1	CORD, POWER	230V KOR	
16	QK1-1396-010		1	CORD, POWER	230V CHN	
17	FH2-7092-020		1	WIRE, GROUND	100V	
18	QE1-2334-000		1	SCREW, ALLEN, M4X6		
19	XA9-1501-000		8	SCREW, RS, M3X10	iPF8100/8000S/8000	

FIGURE & KEY NO.	PARTS NUMBER	RANK	Q'TY	DESCRIPTION	SERIAL NUMBER/REMARKS	SVC
19	XA9-1501-000		4	SCREW, RS, M3X10	iPF8300/8300S	
20	QM3-3267-010		1	FLANGE, SPOOL	iPF8300/8300S	
21	QL2-2916-000		1	DRIVE SPOOL UNIT, RIGHT	iPF8300/8300S	
22	QM3-3269-010		1	HOLDER, ROLL	iPF8300/8300S	
23	QM3-3268-010		1	HOLDER, ROLL	iPF8300/8300S	
24	QM3-4876-010		1	SHAFT, SPOOL	iPF8300/8300S	

FIGURE 02 COVERS (1)

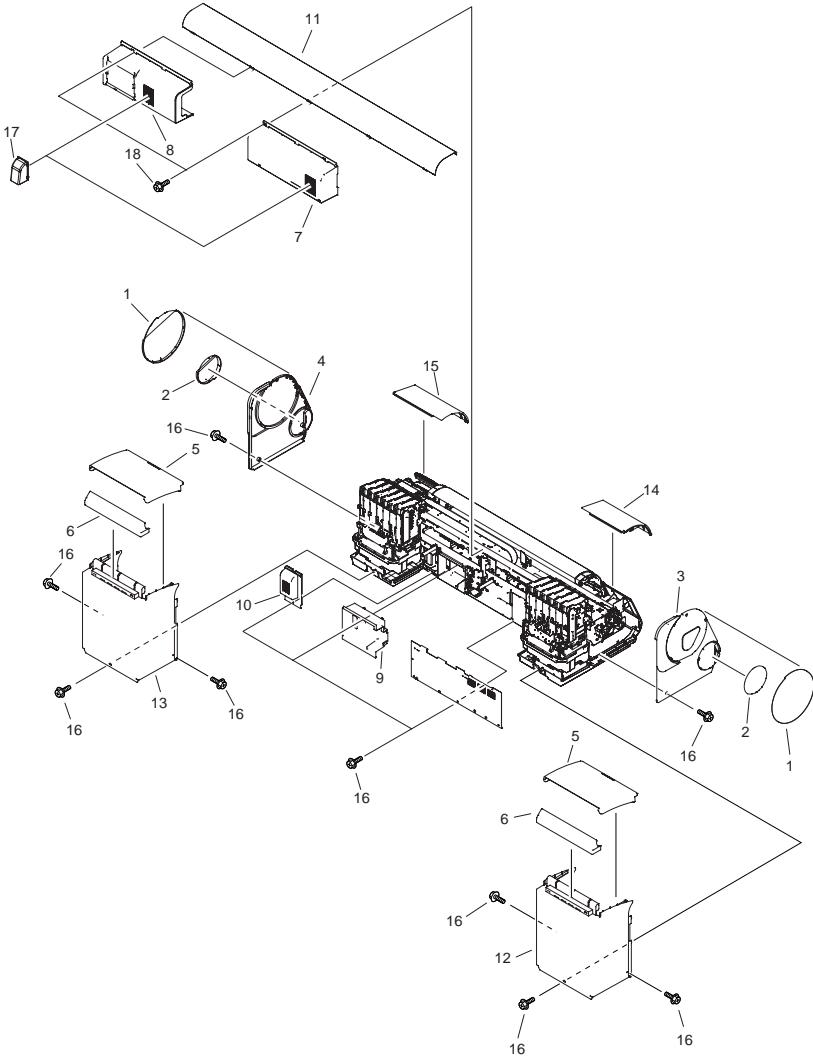

FIGURE & KEY NO.	PARTS NUMBER	R A N K	Q'TY	DESCRIPTION	SERIAL NUMBER/ REMARKS	S V C
Fig.02	NPN		RF	COVERS (1)		
1	QC2-6658-000		2	COVER, CIRCLE(L)	iPF8000S	
1	QC1-6930-000		2	COVER, CIRCLE(L)	iPF8100/8000	
1	QC3-2714-000		2	COVER, CIRCLE(L)	iPF8300/8300S	
2	QC2-6659-000		2	COVER, CIRCLE(S)	iPF8000S	
2	QC1-6931-000		2	COVER, CIRCLE(S)	iPF8100/8000	
2	QC3-2715-000		2	COVER, CIRCLE(S)	iPF8300/8300S	
3	QC2-2191-000		1	COVER, SIDE, LEFT		
4	QC2-2192-000		1	COVER, SIDE, RIGHT		
5	QC2-2181-000		2	COVER, TANK, UPPER		
6	QC2-2183-000		2	COVER, TANK, REAR		
7	QC2-2198-000		1	COVER, REAR, LEFT		
8	QC2-2199-000		1	COVER, REAR, RIGHT		
9	QC2-4064-040		1	COVER, INTERFACE		
10	QC2-2202-030		1	COVER, EXHAUST		
11	QL2-3402-000		1	COVER, REAR, UPPER		
12	QL2-1692-000		1	COVER, TANK, LEFT		
13	QL2-1697-000		1	COVER, TANK, RIGHT		
14	QM3-3026-000		1	COVER, LEFT, UPPER	iPF8300/8300S	
14	QM3-1031-000		1	COVER, LEFT, UPPER	iPF8100/8000	
14	QM3-6505-000		1	COVER, LEFT, UPPER	iPF8300	
15	QM3-2007-000		1	RIGHT COVER UNIT	iPF8000	
15	QM3-3032-000		1	RIGHT COVER UNIT	iPF8000S	
15	QM3-3031-000		1	RIGHT COVER UNIT	iPF8100	
15	QM3-6511-000		1	RIGHT COVER UNIT	iPF8300	
15	QM3-9936-000		1	RIGHT COVER UNIT	iPF8300S	
16	XA9-0732-000		28	SCREW, RS, M4		
17	QC2-6679-000		2	COVER, EXHAUST	iPF8300/8300S/8100/ 8000S	
18	XA9-2027-000		6	SCREW, RS, M4		

FIGURE 03
COVERS (2)

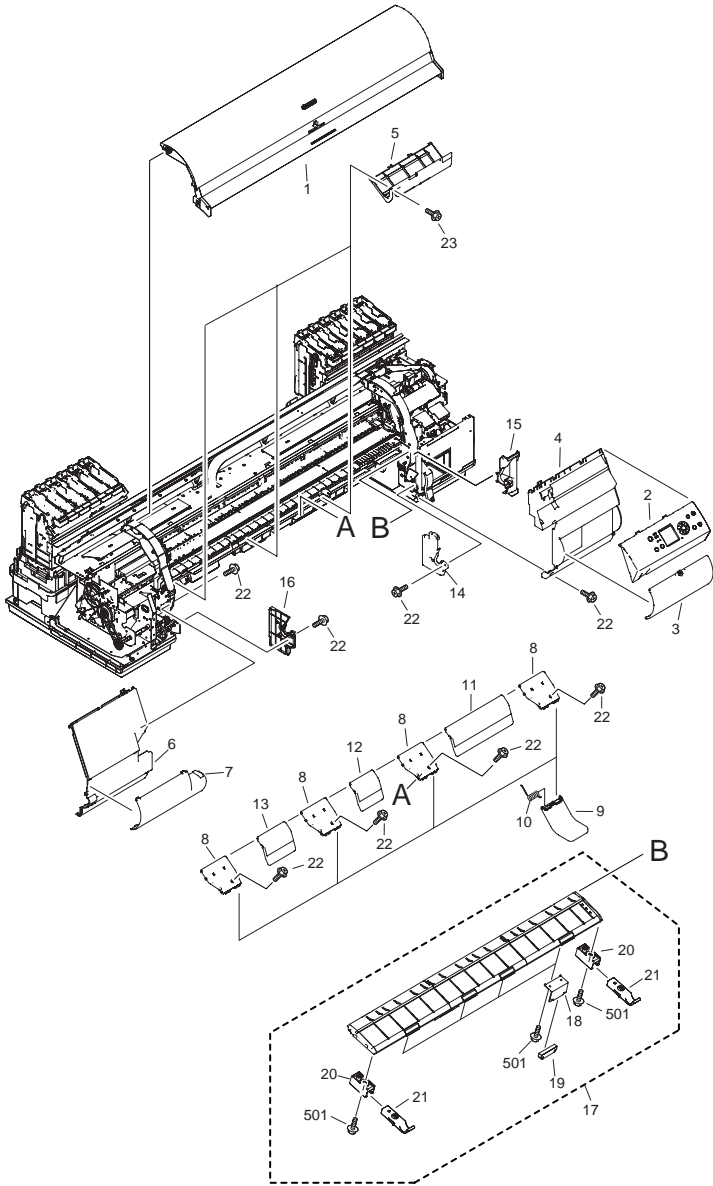

FIGURE & KEY NO.	PARTS NUMBER	R A N K	Q'TY	DESCRIPTION	SERIAL NUMBER/ REMARKS	S V C
Fig.03	NPN		RF	COVERS (2)		
1	QM3-2008-030		1	UPPER COVER UNIT	iPF8100/8000	
1	QM3-3033-030		1	UPPER COVER UNIT	iPF8000S	
1	QM3-6508-000		1	UPPER COVER UNIT	iPF8300	
1	QM3-9945-000		1	UPPER COVER UNIT	iPF8300S	
2	QM3-0969-000		1	OPERATION PANEL UNIT	iPF8000(ENGLISH)	
2	QM3-0970-000		1	OPERATION PANEL UNIT	iPF8000(JAPANESE)	
2	QM3-3108-000		1	OPERATION PANEL UNIT	iPF8100(ENGLISH)	
2	QM3-3109-000		1	OPERATION PANEL UNIT	iPF8100(JAPANESE)	
2	QM3-3165-000		1	OPERATION PANEL UNIT	iPF8000S(ENGLISH)	
2	QM3-3166-000		1	OPERATION PANEL UNIT	iPF8000S(JAPANESE)	
2	QM3-6509-010		1	OPERATION PANEL UNIT	iPF8300(ENGLISH)	
2	QM3-6510-010		1	OPERATION PANEL UNIT	iPF8300(JAPANESE)	
2	QM3-9934-000		1	OPERATION PANEL UNIT	iPF8300S(ENGLISH)	
2	QM3-9935-000		1	OPERATION PANEL UNIT	iPF8300S(JAPANESE)	
3	QC2-2178-020		1	COVER, CARTRIDGE	iPF8100/8000	
3	QC2-6657-020		1	COVER, CARTRIDGE	iPF8000S	
3	QC3-2713-000		1	COVER, CARTRIDGE	iPF8300	
4	QL2-2101-000		1	COVER, RIGHT	iPF8100/8000S/8000	
4	QC2-2177-000		1	COVER, RIGHT	iPF8300/8300S	
5	QM2-2495-010		3	FEED UPPER GUIDE UNIT		
6	QC2-2172-000		1	COVER, LEFT		
7	QC2-2173-000		1	COVER, LEFT, LOWER	iPF8300S/8100/8000	
7	QC2-6660-000		1	COVER, LEFT, LOWER	iPF8000S	
7	QC3-2716-000		1	COVER, LEFT, LOWER	iPF8300	
8	QC1-6924-000		4	GUIDE A, FEED LOWER		
9	QC1-7278-000		4	ARM, LOWER GUIDE		
10	QU1-2185-000		4	SPRING, TORSION		
11	QC1-6925-000		1	GUIDE B, FEED LOWER		
12	QC1-6926-000		1	GUIDE C, FEED LOWER		
13	QC1-6927-000		1	GUIDE D, FEED LOWER		
14	QC2-2179-000		1	COVER, SPOOL RECEIVE, RIGHT, 1		

FIGURE & KEY NO.	PARTS NUMBER	RANK	Q'TY	DESCRIPTION	SERIAL NUMBER/REMARKS	SVC
15	QC2-2180-000		1	COVER, SPOOL RECEIVE, RIGHT, 2		
16	QL2-1668-000		1	COVER, SPOOL RECEIVE, LEFT	iPF8100/8000S/8000	
16	QC3-3648-000		1	COVER, SPOOL RECEIVE, LEFT	iPF8300/8300S	
17	QM3-1996-000		1	ROLL PAPER COVER UNIT		
18	QC1-7138-000		4	MOUNT, ASSIST, DELIVERY		
19	QC1-7143-000		4	SHEET, DELIVERY ASSIST		
20	QC2-3113-000		2	HOOK, BASKET		
21	QC2-3114-000		2	MOUNT, HOOK		
22	XA9-0732-000		13	SCREW, RS, M4		
23	QC1-7399-000		6	SCREW, STEPPED, M4		
501	XB1-2400-806		10	SCREW, MACH, TRUSS HEAD, M4X6		

FIGURE & KEY NO.	PARTS NUMBER	R A N K	Q'TY	DESCRIPTION	SERIAL NUMBER/REMARKS	S V C
Fig.04	NPN		RF	ELECTRICAL PART		
1	QM3-0957-000		1	MAIN BOARD DIMM ASS'Y	iPF8000	
1	QM3-3187-000		1	MAIN BOARD DIMM ASS'Y	iPF8000S	
1	QM3-3131-000		1	MAIN BOARD DIMM ASS'Y	iPF8100	
1	QM3-3153-000		1	MAIN BOARD DIMM ASS'Y	iPF8300	
1	QM3-3202-000		1	MAIN BOARD DIMM ASS'Y	iPF8300S	
2	WK1-5024-000		1	LITHIUM BATTERY		
3	QK1-2912-000		1	POWER SUPPLY ASS'Y		
4	QM3-1047-000		1	INLET UNIT	iPF8300(100V)/ 8300S(100V)/8100/8000S/ 8000	
4	QM3-7036-000		1	INLET UNIT	iPF8300(120V/230V)/ 8300S(120V/230V)	
5	QM3-0983-000		1	TAKE-UP UNIT RELAY PCB ASSY		
6	WP2-5187-000		1	SENSOR UNIT, HUMIDITY		
7	XA9-0732-000		5	SCREW, RS, M4		
8	QM3-3029-010		1	HDD UNIT, WD800BEVT-22ZCT0	iPF8300/8100/8000S	
8	QM3-5254-000		1	HDD UNIT, HTS545016B9A300	iPF8300S	
9	QM3-1149-000		1	HARNESS, WIRE, MAIN	iPF8000	
10	QM3-3113-000		1	HARNESS, WIRE, MAIN	iPF8100/8000S	
11	FK2-2416-000		1	HDD, WD800BEVT-22ZCT0	iPF8300/8100/8000S	
11	WM2-5272-000		1	HDD, HTS545016B9A300	iPF8300S	
501	XB1-2400-606		13	SCREW, MACHINE M4X6		
502	XB1-2300-606		4	SCREW, MACHINE M3X6		
503	XB1-2300-406		4	SCREW, MACH, TRUSS HEAD, M3X4		

FIGURE 05 INK TANK & PURGE UNIT

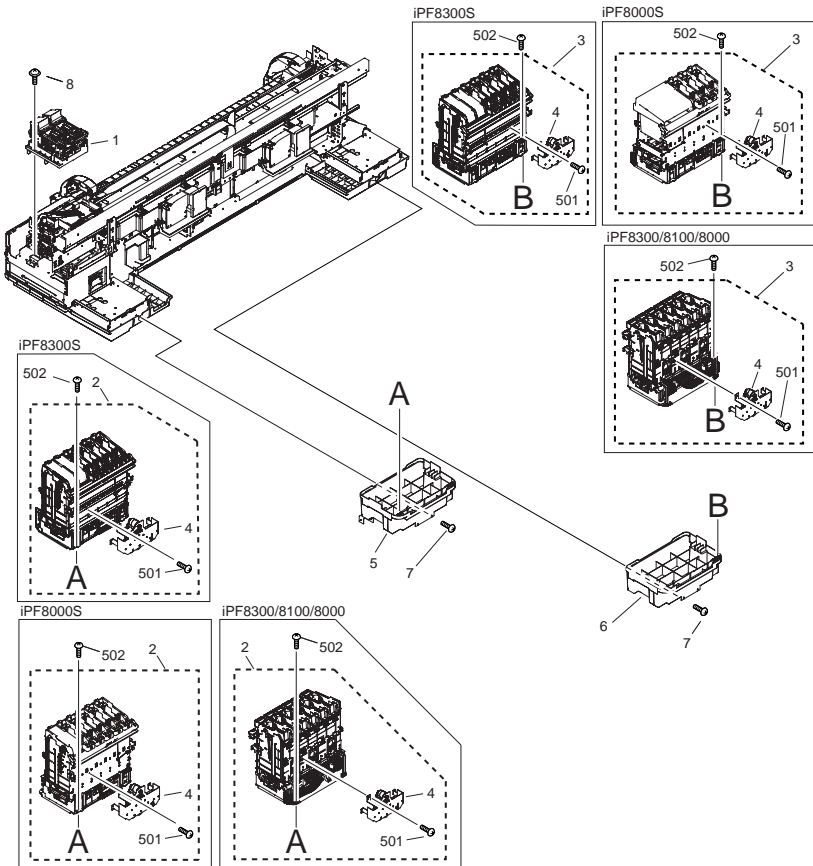

FIGURE & KEY NO.	PARTS NUMBER	R A N K	Q'TY	DESCRIPTION	SERIAL NUMBER/ REMARKS	S V C
Fig.05	NPN		RF	INK TANK & PURGE UNIT		
1	QM3-1004-010		1	PURGE UNIT	iPF8100/8000S/8000	
1	QM3-7018-000		1	PURGE UNIT	iPF8300/8300S	
2	QM3-1005-000		1	INK TANK UNIT R	iPF8000	
2	QM3-3072-000		1	INK TANK UNIT R	iPF8000S	
2	QM3-3080-000		1	INK TANK UNIT R	iPF8100	
2	QM3-6512-000		1	INK TANK UNIT R	iPF8300	
2	QM3-9937-000		1	INK TANK UNIT R	iPF8300S	
3	QM3-1006-000		1	INK TANK UNIT L	iPF8000	
3	QM3-3073-000		1	INK TANK UNIT L	iPF8000S	
3	QM3-3081-000		1	INK TANK UNIT L	iPF8100	
3	QM3-6513-000		1	INK TANK UNIT L	iPF8300	
3	QM3-9938-000		1	INK TANK UNIT L	iPF8300S	
4	QM3-1055-000		2	INK SUPPLY DRIVE UNIT		
5	QM3-1034-020		1	INK SUPPLY MOUNT UNIT (R)		
6	QM3-1033-020		1	INK SUPPLY MOUNT UNIT (L)		
7	XA9-0732-000		4	SCREW, RS, M4		
8	XA9-2027-000		3	SCREW, RS, M4		
501	XB1-2300-607		6	SCREW, BH3X6(S)		
502	XB5-2400-809		4	SCREW, TAPPING M4X8		

FIGURE 06 CARRIAGE UNIT

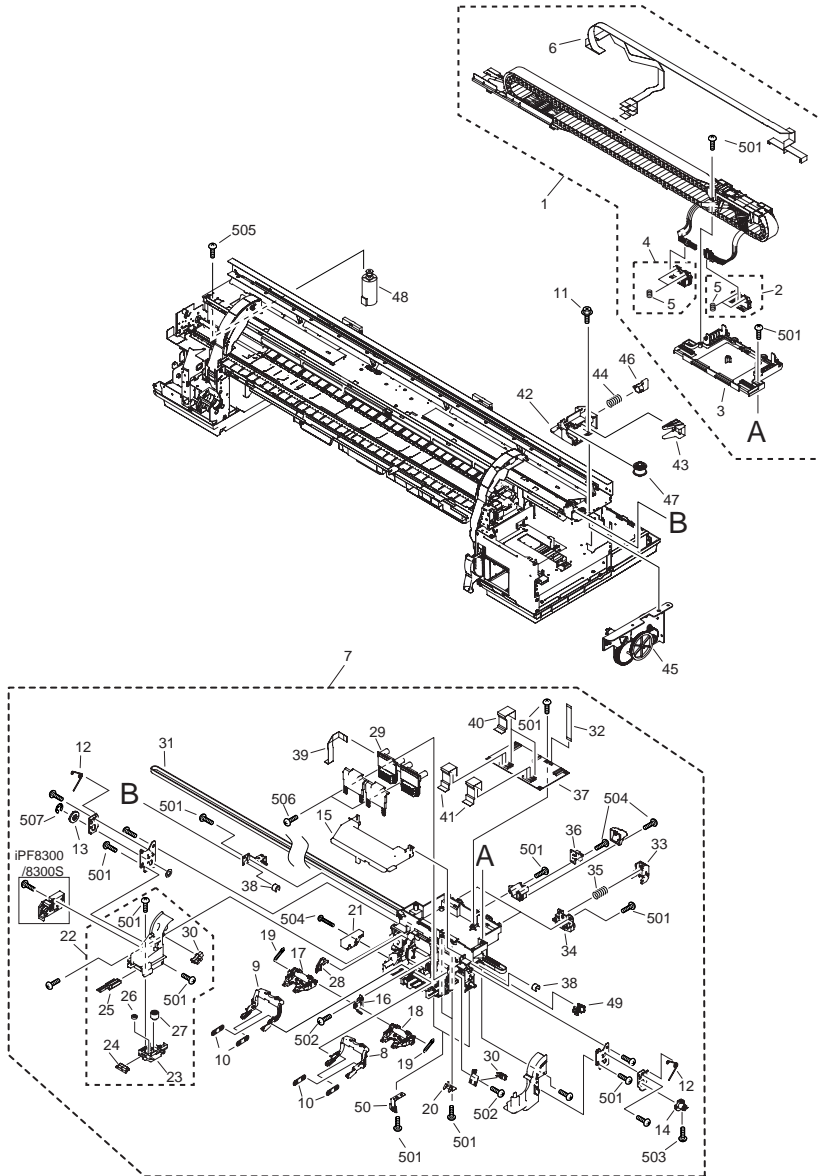

FIGURE & KEY NO.	PARTS NUMBER	R A N K	Q'TY	DESCRIPTION	SERIAL NUMBER/ REMARKS	S V C
Fig.06	NPN		RF	CARRIAGE UNIT		
1	QM3-2004-040		1	TUBE UNIT	iPF8000	
1	QM3-3091-020		1	TUBE UNIT	iPF8000S	
1	QM3-3359-020		1	TUBE UNIT	iPF8100	
1	QM3-7030-000		1	TUBE UNIT	iPF8300	
1	QM3-9943-000		1	TUBE UNIT	iPF8300S	
2	QM3-0584-000		1	BASE UNIT, JOINT		
3	QM3-1017-000		1	UPPER CARRIAGE COVER		
4	QM3-1018-000		1	BASE UNIT, JOINT, LEFT		
5	QU1-2005-000		4	SPRING, COMPRESSION		
6	QM3-2005-020		1	FLEXIBLE CABLE ASS'Y		
7	QM3-1995-060		1	CARRIAGE UNIT	iPF8000	
7	QM3-3093-000		1	CARRIAGE UNIT	iPF8100/8000S	
7	QM3-7033-000		1	CARRIAGE UNIT	iPF8300/8300S	
8	QC2-0659-050		1	LEVER R, INK TUBE		
9	QC2-0660-050		1	LEVER L, INK TUBE		
10	QC2-0661-000		4	LINK LEVER, TUBE		
11	XA9-0732-000		4	SCREW, RS, M4		
12	QC2-2078-000		2	SPRING, TORSION		
13	QC2-2104-000		1	CAM, LIFT, LEFT	iPF8100/8000S/8000	
13	QC3-2769-000		1	CAM, LIFT, LEFT	iPF8300/8300S	
14	QC2-2106-000		1	CAM, LIFT, RIGHT	iPF8100/8000S/8000	
14	QC3-2770-000		1	CAM, LIFT, RIGHT	iPF8300/8300S	
15	QC2-3138-000		1	COVER, CARRIAGE		
16	QC2-0653-000		1	HOLDER, LEVER SET PRINTHEAD		
17	QM3-0541-000		1	HEAD LEVER UNIT		
18	QM3-0560-000		1	HEAD LEVER UNIT		
19	QU1-2006-000		2	SPRING, COMPRESSION		
20	QC1-7156-000		2	STOPPER, BELT		
21	QM2-3426-000		1	MULTI SENSOR UNIT	iPF8000	
21	QM3-3138-000		1	MULTI SENSOR UNIT	iPF8300/8300S/8100/ 8000S	

FIGURE & KEY NO.	PARTS NUMBER	R A N K	Q'TY	DESCRIPTION	SERIAL NUMBER/ REMARKS	S V C
22	QM3-1044-010		1	CUTTER HOLDER UNIT		
23	QC2-2364-000		1	HOLDER, GEAR		
24	QC2-2365-000		1	RACK		
25	QC2-2366-000		1	LEVER		
26	QU1-0130-000		1	GEAR, 20T		
27	QU1-0131-000		1	GEAR, 20T/36T		
28	QC2-0710-000		1	COVER, FFC MULTI SENSOR		
29	QM3-0979-000		1	HEAD RELAY PCB ASS'Y	iPF8000	
29	QM3-3106-000		1	HEAD RELAY PCB ASS'Y	iPF8100/8000S	
29	QM3-3139-000		1	HEAD RELAY PCB ASS'Y	iPF8300/8300S	
30	WG8-5624-000		2	IC, PHOTO INTERRUPTER		
31	QC2-4036-000		1	BELT, CARRIAGE		
32	QK1-2985-000		1	CABLE, FLEXIBLE		
33	QL2-1104-000		2	IDLER ROLLER UNIT	iPF8000	
33	QL2-2443-000		2	IDLER ROLLER UNIT	iPF8300/8300S/8100/ 8000S	
34	QL2-1114-000		2	IDLER ROLLER HOLDER UNIT	iPF8000	
34	QL2-2442-000		2	IDLER ROLLER HOLDER UNIT	iPF8300/8300S/8100/ 8000S	
35	QU1-2175-000		2	SPRING, COIL		
36	QM2-3421-010		1	ENCODER SENSOR UNIT	iPF8000	
36	QM3-3112-000		1	ENCODER SENSOR UNIT	iPF8300/8300S/8100/ 8000S	
37	QM3-0980-000		1	CARRIAGE RELAY PCB ASS'Y	iPF8000	
37	QM3-3107-000		1	CARRIAGE RELAY PCB ASS'Y	iPF8100/8000S	
37	QM3-3121-000		1	CARRIAGE RELAY PCB ASS'Y	iPF8300/8300S	
38	QU1-1004-000		2	BUSHING		
39	QK1-2091-000		1	CABLE, MULTI SENSOR	iPF8000	
39	QK1-2758-000		1	CABLE, MULTI SENSOR	iPF8300/8300S/8100/ 8000S	
40	QK1-2983-000		2	CABLE, FLEXIBLE		
41	QK1-2984-000		4	CABLE, FLEXIBLE		
42	QC1-7303-000		1	MOUNT, IDLER ROLLER		
43	QC2-3137-000		1	GUIDE, IDLER ROLLER		

FIGURE & KEY NO.	PARTS NUMBER	R A N K	Q'TY	DESCRIPTION	SERIAL NUMBER/ REMARKS	S V C
44	QE1-1270-000		1	SPRING, COIL		
45	QM3-1020-000		1	LIFT DRIVE UNIT		
46	QE1-2691-000		1	LEVER, IDLER ROLLER		
47	QM1-0662-000		1	IDLER ROLLER ASS'Y		
48	QK1-2868-000		1	MOTOR, CARRIAGE		
49	QM2-2572-000		1	RAIL CLEANER ASS'Y		
50	QL2-1125-000		2	SLIDER, RAIL		
501	XB4-7401-009		32	SCREW, TAP., PAN HEAD, M4X10		
502	XB4-7300-809		3	SCREW, TAP, BINDING HEAD, M3X8		
503	XB1-2300-806		1	SCREW, BH3X8		
504	XB4-5300-806		2	SCREW, TAP., TRUSS HEAD M3X8		
505	XB1-2400-606		4	SCREW, MACHINE M4X6		
506	XB4-7301-009		4	SCREW, BINDING HEAD SELF-TPG		
507	XD1-1100-502		1	SHIM		

FIGURE 07 FEED MOTOR ASS'Y

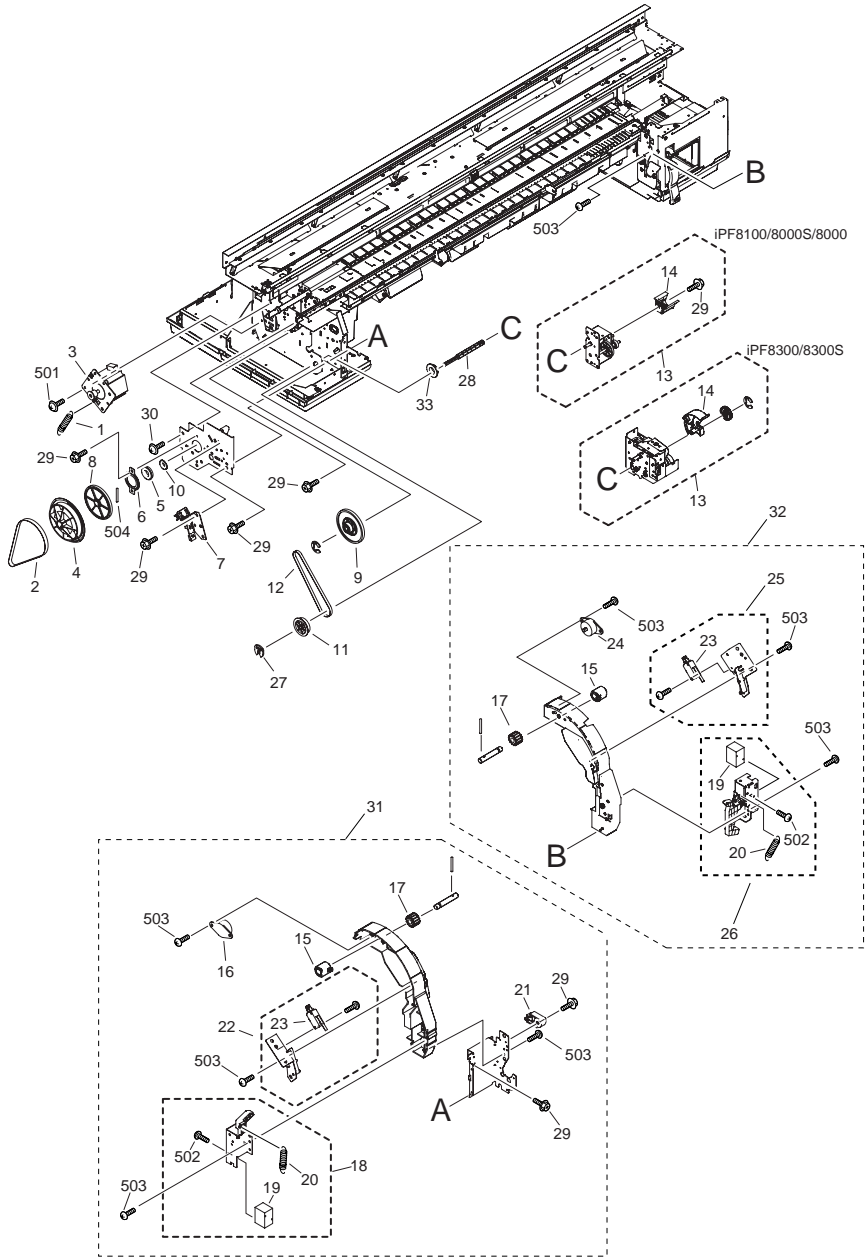

FIGURE & KEY NO.	PARTS NUMBER	RANK	Q'TY	DESCRIPTION	SERIAL NUMBER/REMARKS	SVC
Fig.07	NPN		RF	FEED MOTOR ASS'Y		
1	QU1-2170-000		1	SPRING, HOOK END COIL		
2	XF2-4119-790		1	BELT, FEED	iPF8000	
2	XF2-4119-770		1	BELT, FEED	iPF8300/8300S/8100/8000S	
3	QM2-2502-000		1	FEED MOTOR ASS'Y		
4	QL2-2095-000		1	PULLEY ASS'Y		
5	XG9-0453-000		1	BEARING, BALL, 6902ZZNR, NSK		
6	QC1-6847-000		1	SUPPORT, BEARING		
7	QM3-1106-000		1	SENSOR UNIT		
8	QU1-0082-000		1	GEAR 76T		
9	QU1-0083-000		1	GEAR, PULLY 76T/36T		
10	QU1-6016-000		1	COLLAR, FEED ROLLER		
11	QU1-0084-000		1	GEAR 56T		
12	XF2-4117-360		1	BELT, DRIVE		
13	QM2-2526-000		1	SPOOL DRIVE UNIT	iPF8100/8000S/8000	
13	QM3-7034-000		1	SPOOL DRIVE UNIT	iPF8300/8300S	
14	QC1-7092-000		1	COVER, GEAR	iPF8100/8000S/8000	
14	QC3-3653-000		1	COVER, GEAR	iPF8300/8300S	
15	QC2-4136-000		2	COUPLING, DAMPER		
16	QC1-7068-000		1	DAMPER, LEFT		
17	QE1-1063-000		2	GEAR 14T		
18	QM2-2511-000		1	UPPER COVER LOCK UNIT L		
19	FH7-5489-050		2	SOLENOID, DC24V		
20	QU1-2173-000		2	SPRING, HOOK END COIL		
21	QC1-7141-000		1	STOPPER, COVER		
22	QM3-1024-000		1	UPPER COVER SWITCH UNIT L		
23	WC4-5180-000		2	MICROSWITCH (DOOR)		
24	QC1-7067-000		1	DAMPER, RIGHT		
25	QM3-1026-000		1	UPPER COVER SWITCH UNIT R		
26	QM3-1027-000		1	UPPER COVER LOCK UNIT R		
27	FA3-8727-000		1	RETAINING RING		

FIGURE & KEY NO.	PARTS NUMBER	RANK	Q'TY	DESCRIPTION	SERIAL NUMBER/REMARKS	SVC
28	QC2-2195-000		1	SHAFT, JOINT		
29	XA9-0732-000		11	SCREW, RS, M4		
30	XA9-0249-000		3	SCREW, M4X8		
31	QM3-2016-000		1	COVER STAY UNIT L	IPF8100/8000S/8000	
31	QM3-7032-000		1	COVER STAY UNIT L	IPF8300/8300S	
32	QM3-1025-000		1	COVER STAY UNIT R	IPF8100/8000S/8000	
32	QM3-7042-000		1	COVER STAY UNIT R	IPF8300/8300S	
33	FS5-1189-000		1	BUSHING		
501	XB2-8401-009		4	SCREW, W/WASHER, M4X10		
502	XB1-2300-406		4	SCREW, MACH, TRUSS HEAD, M3X4		
503	XB4-5400-806		12	SCREW, P, M4X8		
504	XD3-2200-222		1	PIN		

FIGURE & KEY NO.	PARTS NUMBER	R A N K	Q'TY	DESCRIPTION	SERIAL NUMBER/REMARKS	S V C
Fig.08	NPN		RF	AIR FLOW FAN UNIT		
1	QL2-2110-000		1	WASTE INK ABSORBER UNIT		
2	QL2-2114-000		1	DUCT ASS'Y		
3	QL2-1650-000		1	WASTE INK ABSORBER UNIT (S)		
4	QL2-2108-000		2	WASTE INK ABSORBER UNIT (L)		
5	QM3-1012-000		1	SUCTION FAN UNIT	iPF8000	
5	QM3-3069-000		1	SUCTION FAN UNIT	iPF8300/8300S/8100/8000S	
6	QM3-1056-000		1	HEAD MANAGEMENT SENSOR		
7	QC1-7237-000		1	ABSORBER, INK		
8	QM3-1419-000		1	M/C RELAY PCB ASS'Y	iPF8100/8000S/8000	
8	QM3-4843-000		1	M/C RELAY PCB ASS'Y	iPF8300/8300S	
9	QM3-1038-000		2	FAN UNIT	iPF8100/8000S/8000	
9	QM3-7025-000		2	FAN UNIT	iPF8300/8300S	
10	QC1-9198-000		2	FILTER, MIST		
11	QK1-1387-000		2	FAN, MIST		
12	QM3-2064-000		6	DUCT UNIT	iPF8100/8000S/8000	
12	QL2-2823-000		6	DUCT UNIT	iPF8300/8300S	
13	QL2-1663-000		1	DUCT		
14	XA9-0732-000		15	SCREW, RS, M4		
15	XA9-2027-000		1	SCREW, RS, M4		
501	XB4-7404-009		4	SCREW, TAP BINDING HEAD, M4X40		
502	XB4-7402-509		18	SCREW, TAP., TRUSS HEAD, M4X25		

FIGURE 09 PINCH ROLLER UNIT

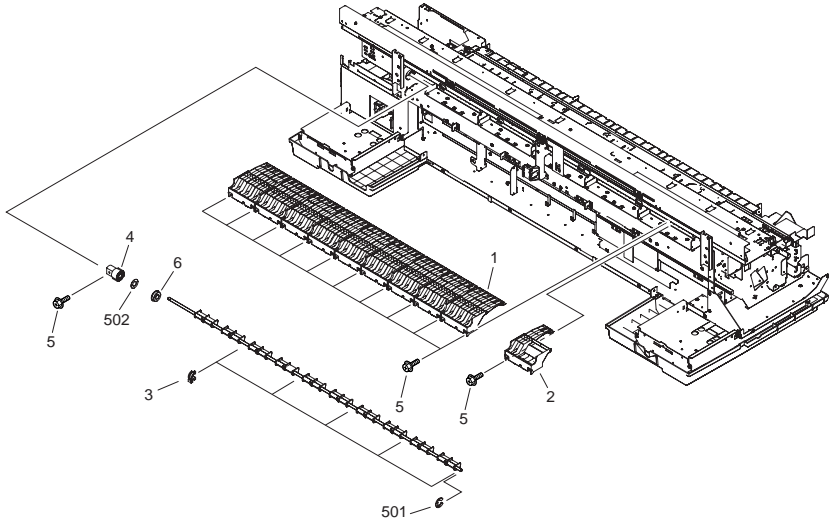

FIGURE & KEY NO.	PARTS NUMBER	RANK	QTY	DESCRIPTION	SERIAL NUMBER/REMARKS	SVC
Fig.09	NPN		RF	PINCH ROLLER UNIT		
1	QM2-2596-050		9	PINCH ROLLER UNIT		
2	QM2-2597-000		1	PINCH ROLLER UNIT	iPF8000	
2	QM3-4829-000		1	PINCH ROLLER UNIT	iPF8300/8300S/8100/8000S	
3	QC1-6999-000		5	BUSHING		
4	QE1-1048-000		1	GEAR		
5	XA9-0732-000		21	SCREW, RS, M4		
6	XG9-0549-000		1	BEARING, BALL	iPF8000	
6	XG9-0365-000		1	BEARING, BALL	iPF8300/8300S/8100/8000S	
501	XD2-1100-642		1	RING, E		
502	XD1-1108-219		1	WASHER, COP		

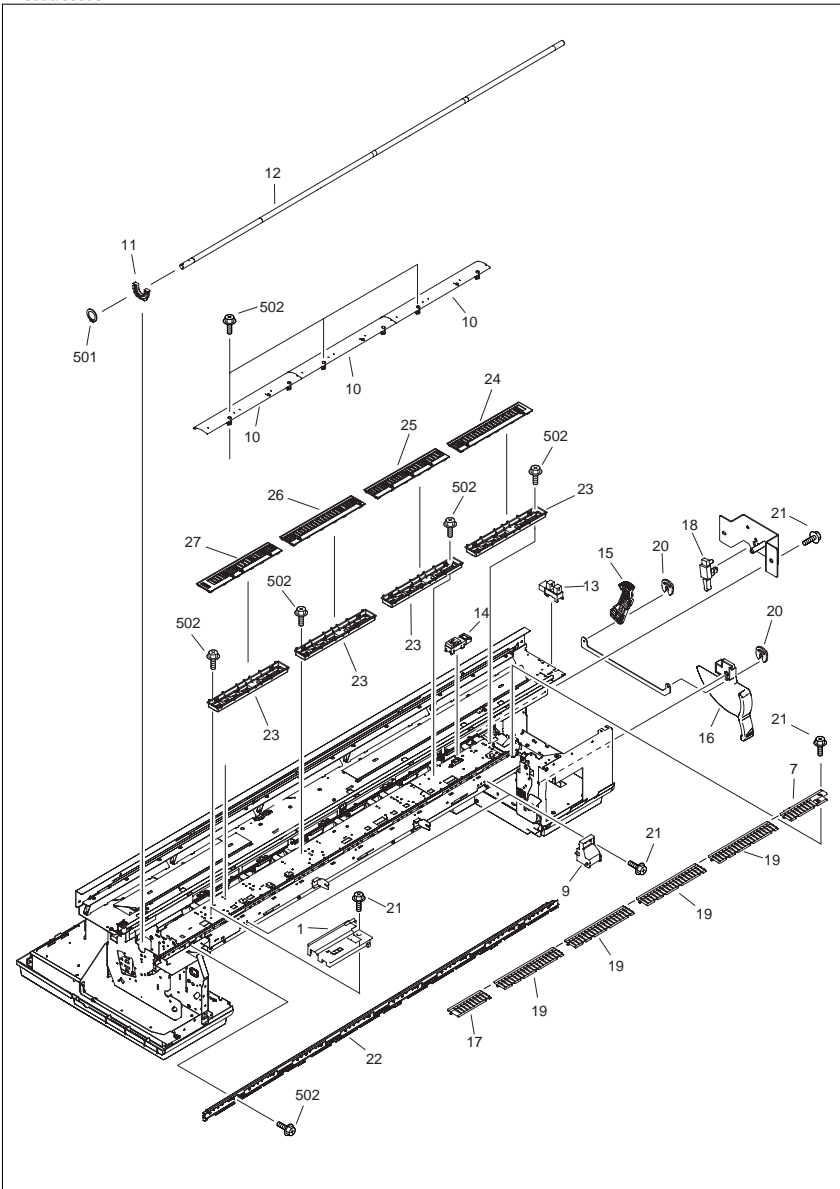

FIGURE & KEY NO.	PARTS NUMBER	R A N K	Q'TY	DESCRIPTION	SERIAL NUMBER/ REMARKS	S V C
Fig.10	NPN		RF	PLATEN & FEED ROLLER		
1	QL2-2089-000		1	MOUNT, SENSOR ADJUSTING	iPF8100/8000S/8000	
1	QL2-3279-000		1	MOUNT, SENSOR ADJUSTING	iPF8300/8300S	
2	QL2-2784-000		1	BASE, PLATEN L	iPF8100/8000S/8000	
3	QL2-2783-000		1	BASE, PLATEN C	iPF8100/8000S/8000	
4	QL2-1659-000		1	PLATEN R	iPF8100/8000S/8000	
5	QL2-1660-000		1	PLATEN C	iPF8100/8000S/8000	
6	QL2-2109-000		1	PLATEN L	iPF8100/8000S/8000	
7	QC2-2355-000		1	GUIDE, DELIVERY, RIGHT		
8	QL2-2782-000		1	BASE, PLATEN R	iPF8100/8000S/8000	
9	QM2-2528-010		2	COVER LOCK UNIT		
10	QC1-6921-000		3	PLATEN, REAR		
11	QC2-2082-000		1	BUSHING		
12	QM3-1999-010		1	FEED ROLLER ASS'Y	iPF8100/8000S/8000	
12	QM3-7026-000		1	FEED ROLLER ASS'Y	iPF8300/8300S	
13	WG8-5624-000		1	IC, PHOTO INTERRUPTER		
14	WG8-5677-000		1	PHOTO-INTERRUPTER		
15	QC1-7043-000		1	GEAR, RELEASE		
16	QC1-7034-000		1	LEVER, RELEASE		
17	QC2-2356-000		1	GUIDE, DELIVERY, LEFT		
18	WC4-5052-000		1	MICRO SWITCH		
19	QC2-2354-000		4	GUIDE, DELIVERY		
20	FA3-8727-000		2	RING, RETAINING		
21	XA9-0732-000		36	SCREW, RS, M4		
22	QM3-2003-000		1	BLADE, CUTTER 44 (U)		
23	QL2-3385-000		4	BASE, PLATE	iPF8300/8300S	
24	QM3-7700-000		1	PLATEN R	iPF8300/8300S	
25	QM3-7701-000		1	PLATEN C	iPF8300/8300S	
26	QM3-7702-000		1	PLATEN C	iPF8300/8300S	
27	QM3-7703-000		1	PLATEN L	iPF8300/8300S	
501	XD2-3100-152		1	RING, C		
502	XA9-0724-000		6	SCREW, M3X8		

FIGURE 11 LINEAR SCALE

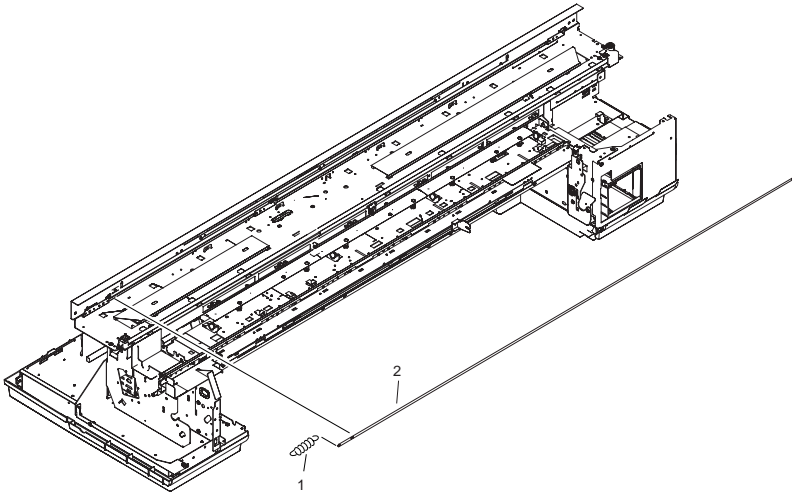

FIGURE & KEY NO.	PARTS NUMBER	RANK	QTY	DESCRIPTION	SERIAL NUMBER/REMARKS	SVC
Fig.11	NPN		RF	LINEAR SCALE		
1	QU1-2169-000		1	SPRING, HOOK END COIL		
2	QC3-1877-000		1	SCALE, LINEAR		

FIGURE 12 TOOL

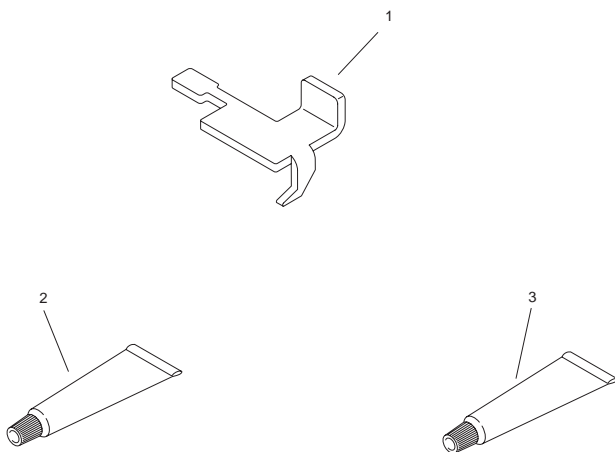

FIGURE & KEY NO.	PARTS NUMBER	RANK	QTY	DESCRIPTION	SERIAL NUMBER/REMARKS	S V C
Fig.12	NPN		RF	TOOL		
1	QY9-0103-000		1	COVER SWITCH TOOL		
2	CK-0551-020		1	LUBE, PERMALUB G NO.2		
3	CK-0562-000		1	GREASE, MOLYKOTE PG-641		

FIGURE R1 STAND UNIT

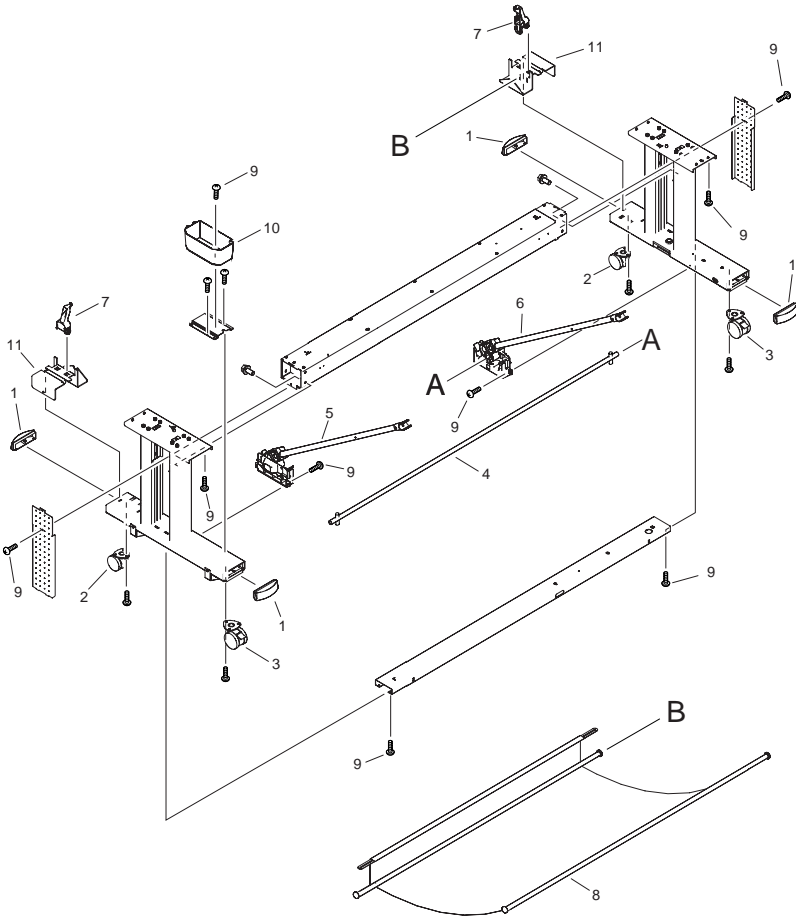

FIGURE & KEY NO.	PARTS NUMBER	R A N K	Q'TY	DESCRIPTION	SERIAL NUMBER/ REMARKS	S V C
Fig.R1	NPN		RF	STAND UNIT		
1	QC2-6626-000		4	CAP, FOOT		
2	QC2-4350-000		2	CASTER		
3	QC2-4351-000		2	CASTER		
4	QL2-2327-000		1	ROD, BASKET		
5	QM3-2022-000		1	BASKET SUPPORT (L)		
6	QM3-2023-000		1	BASKET SUPPORT (R)		
7	QC2-6025-000		2	HOLDER, REAR		
8	QM3-2854-000		1	BASKET		
9	QC2-4116-000		20	SCREW, HEX SOCKET M4X10		
10	QC3-1731-000		1	BOX, ACCESSORY		
11	QL2-2326-000		2	MOUNT, HOLDER, ROD		

FIGURE & KEY NO.	PARTS NUMBER	R A N K	Q'TY	DESCRIPTION	SERIAL NUMBER/ REMARKS	S V C
Fig.R2	NPN		RF	MEDIA TAKE-UP UNIT		
1	QK1-2908-000		1	CABLE, INTERFACE		
2	WG8-5770-000		1	IC, PID310L, PHOTO-INTERRUPTER		
3	WG8-5771-000		1	IC, PIE310, PHOTO-INTERRUPTER		
4	QM3-1092-000		1	MEDIA TAKE-UP DRIVE UNIT		
5	QC2-2399-000		1	KNOB		
6	QC2-2401-000		1	LEVER, LOCK		
7	QC2-2402-000		1	LEVER, RELEASE		
8	QC2-2403-000		1	GEAR, 14T		
9	QC2-2404-000		1	GEAR, 22T		
10	QC2-2408-000		1	SPRING, TORSION		
11	QC2-2409-000		1	SPRING, TORSION		
12	QC2-2410-000		1	COVER, DRIVE UNIT, 1		
13	QC2-2412-000		1	COVER, DRIVE UNIT, 2		
14	WG8-5624-000		1	IC, PHOTO INTERRUPTER		
15	QM3-1093-000		1	MEDIA TAKE-UP IDLER UNIT		
16	QM3-1108-000		1	RIGHT FLANGE UNIT		
17	QM3-1109-000		1	LEFT FLANGE UNIT		
18	QM3-1095-000		2	3 INCH ADAPTER UNIT		
19	QL2-3143-000		1	WEIGHT G		
20	QL2-3145-000		1	WEIGHT E		
21	QL2-3146-000		1	WEIGHT D		
22	QL2-3147-000		1	WEIGHT C		
23	QL2-3148-000		1	WEIGHT A		
24	QL2-3149-000		1	WEIGHT B		
25	QL2-1676-000		2	WEIGHT FLANGE 1		
26	QL2-2094-000		2	WEIGHT FLANGE 2		
27	QE1-1495-000		1	WEIGHT JOINT		
28	QE1-2304-000		15	BOLT, HEX HEAD, M4X8		
29	XA9-1501-000		4	SCREW, RS, M3X10		
30	QM3-2011-000		1	MEDIA TAKE-UP SPOOL SHAFT UNIT		
31	QC2-2434-000		1	GEAR, 27T		

FIGURE & KEY NO.	PARTS NUMBER	R A N K	Q'TY	DESCRIPTION	SERIAL NUMBER/ REMARKS	S V C
32	QC2-2413-000		1	BRACKET, MOUNTING, RIGHT		
33	QC2-2417-000		1	BRACKET, MOUNTING, LEFT		
34	QM3-1091-000		1	MEDIA TAKE-UP SENSOR UNIT		
501	XB4-7300-807		1	SCREW, TAP TIGHT, BINDING HEAD		
502	XD2-1100-502		2	RETAINING RING (E-TYPE)		
503	XD2-1100-322		1	RETAINING RING (E-TYPE)		

FIGURE ZZA

MECHANICAL STANDARD PARTS(HOW TO USE)

Mechanical standard parts

機械標準部品

About a mechanical standard parts

A Mechanical standard parts is a mechanical part which not parts peculiar to a product. They are parts which are common to a Canon product and are used, such as a screw and a washer. The Fig No. and parts number of the mechanical standard parts are not listed in the product parts catalog. Refer to the parts catalog of mechanical standard parts when checking the parts number for screw or washer etc. and identify them by part shape or size.

機械標準部品とは

機械標準部品とは、製品特有の部品ではなく、ねじやワッシャなどキヤノン製品共通で使用されている機械部品（メカ部品）のことです。
製品のパーツカタログには、機械標準部品のFig No.や部品番号は記載しておりません。
ねじや、ワッシャ等の部品番号を調べるときは、機械標準部品のパーツカタログを参照し、部品の形状や大きさから判断し、使用している部品を調べてください。

Material and surface treatment of a mechanical standard parts

Material and surface treatment of mechanical standard parts are assigned commonly for each part. Refer to the Table 1 for the parts which material and surface treatment are assigned as numbers.

機械標準部品の材料および表面処理

機械標準部品の材料および表面処理については、各種部品共通で決められています。
材料および表面処理が番号で決められている部品については、表1を参照してください。

Table 1 Material and Surface treatment
表1 材料および表面処理

No. 番号	Material 材料	Surface treatment 表面処理	Color 色
1	Stainless steel ステンレス	Stainless steel black coloring (BC4) ステンレス黒着色(BC4)	Black 黒
2		not to be given なし	White 白
3	Brass 黄銅	Regular nickel plating (NL) 普通ニッケルメッキ(NL)	White 白
4		Black nickel plating (BN) 黒色ニッケルメッキ(BN)	Black 黒
5	Steel 鋼	White zinc trivalent chromate treating (ZC3) 白色亜鉛3価クロメート(ZC3)	White 白
6		Regular nickel chromium plating (NC) 普通ニッケルクロムメッキ(NC)	White 白
7		Regular nickel plating (NL) 普通ニッケルメッキ(NL)	White 白
8		Iron and steel phosphating (P1) 鉄鋼磷酸塩処理(P1)	Black 黒
9		Black zinc trivalent chromate treating (BZ3) 黒色亜鉛3価クロメート(BZ3)	Black 黒

FIGURE ZZB

MECHANICAL STANDARD PARTS(SCREWS)

1. Screws ねじ

How to read Parts Numbers
部品番号の見方

Screws
ねじ

XB1-2400-609

Type No.
類別番号

Normal designation (d)
ねじの呼び(d)

Length (L)
ねじの長さ(L)

Material and Surface treatment
材料および表面処理

XB1-2 expresses Binding head machine screw.
XB1-2は、バインドねじを表す

40 expresses M4.0.
40は、M4.0を表す

0-60 expresses a length of 6.0mm.
0-60は、6.0mmの長さを表す

9 expresses Steel (Black zinc trivalent chromate treating) from Table 1.

9は、表1より鋼(黒色亜鉛3価クロメート)を表す

1-1. Cross Recessed Head Screws for Precision Equipments

精密機器用十字穴付き小ねじ

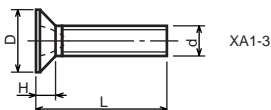
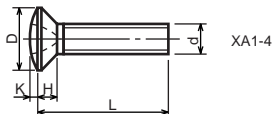
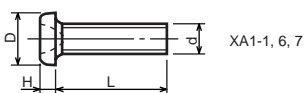

Type No. 類別番号	Type 類別	Head size (mm) 頭部寸法 (mm)							
		M1.4	M1.6	M1.7	M2	M2.5	M2.6		
XA1-1	Pan head Class 1 なべ1種	D	XA1-1	2	2.4	2.5	3	3.8	4
		H	XA1-1	0.5	0.55	0.5	0.6	0.9	0.8
XA1-3	Countersunk head Class 1 さら1種	D	XA1-3	2	2.4	2.5	3	3.8	4
		H	XA1-3	0.48	0.55	0.58	0.73	0.85	0.93
XA1-4	Oval countersunk head Class 1 丸さら1種	D	XA1-4	2	2.4	2.5	3	3.8	4
		H + K	XA1-4	0.68	0.8	0.88	1	1.25	1.3
XA1-6	Pan head Class 3 なべ3種	D	XA1-6	2.5	2.8	3	3.5	4.3	4.5
		H	XA1-6	0.8	0.85	0.9	1	1.3	1.2
XA1-7	Pan head Class 2 なべ2種	D	XA1-7	2.5	2.8	3	3.5	4.3	4.5
		H	XA1-7	0.5	0.55	0.5	0.6	0.9	0.8

1-2. Precision Tapping Screws
精密用タッピンねじ

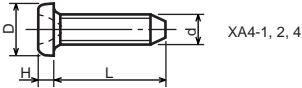

XA4-1, 2, 4

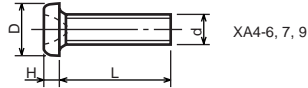

XA4-6, 7, 9

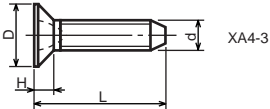

XA4-3

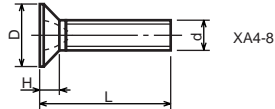

XA4-8

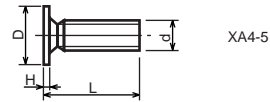

XA4-5

Type No. 類別番号	Type 類別	Head size (mm) 頭部寸法 (mm)						
		M1.4	M1.6	M1.7	M2	M2.5	M2.6	
XA4-1	With tapered end pan head Class 1 絞りなべ1種	D XA4-1	2	2.4	2.5	3	3.8	4
		H XA4-1	0.5	0.55	0.5	0.6	0.9	0.8
XA4-2	With tapered end pan head Class 3 絞りなべ3種	D XA4-2	2.5	2.8	3	3.5	4.3	4.5
		H XA4-2	0.8	0.85	0.9	1	1.3	1.2
XA4-3	With tapered end countersunk head 絞り-さら	D XA4-3	2	2.4	2.5	3	3.8	4
		H XA4-3	0.48	0.55	0.58	0.73	0.85	0.93
XA4-4	With tapered end pan head Class 2 絞りなべ2種	D XA4-4	2.5	2.8	3	3.5	4.3	4.5
		H XA4-4	0.5	0.55	0.5	0.6	0.9	0.8
XA4-5	With parallel end ultra thin head ストレート-超薄頭	D XA4-5	2.5	2.8	3	-	-	-
		H XA4-5	0.2	0.2	0.2	-	-	-
XA4-6	With parallel end pan head Class 1 ストレートなべ1種	D XA4-6	2	2.4	2.5	3	3.8	4
		H XA4-6	0.5	0.55	0.5	0.6	0.9	0.8
XA4-7	With parallel end pan head Class 3 ストレートなべ3種	D XA4-7	2.5	2.8	3	3.5	4.3	4.5
		H XA4-7	0.8	0.85	0.9	1	1.3	1.2
XA4-8	With parallel end countersunk head ストレート-さら	D XA4-8	2	2.4	2.5	3	3.8	4
		H XA4-8	0.48	0.55	0.58	0.73	0.85	0.93
XA4-9	With parallel end pan head Class 2 ストレートなべ2種	D XA4-9	2.5	2.8	3	3.5	4.3	4.5
		H XA4-9	0.5	0.55	0.5	0.6	0.9	0.8

1-3. Cross Recessed Head Screws
一般用十字穴付き小ねじ



XB1-1

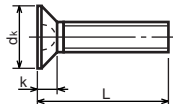

XB1-3

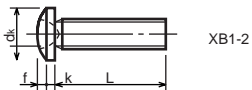

XB1-2

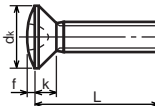

XB1-4

Type No. 類別番号	Type 類別
XB1-1	Pan head なべ
XB1-2	Binding head バインド
XB1-3	Countersunk head さら
XB1-4	Oval countersunk head 丸さら

		Head size (mm) 頭部寸法 (mm)					
		M2	M2.5	M2.6	M3	M4	M5
dk	XB1-1	3.5	4.5	4.5	5.5	7	9
k	XB1-1	1.3	1.7	1.7	2	2.6	3.3
dk	XB1-2	4.3	5.3	5.5	6.3	8.3	10.3
k+f	XB1-2	1.2	1.5	1.6	1.9	2.5	3.1
dk	XB1-3	4	5	-	6	8	10
k	XB1-3	1.2	1.45	-	1.75	2.3	2.8
dk	XB1-4	4	5	-	6	8	10
k+f	XB1-4	1.6	2	-	2.45	3.2	4
Screw part length ねじ部長さ b		8	12	12	12	16	20

1-4. Cross Recessed Head Screws with Captive Washer
座金組込み十字穴付き小ねじ

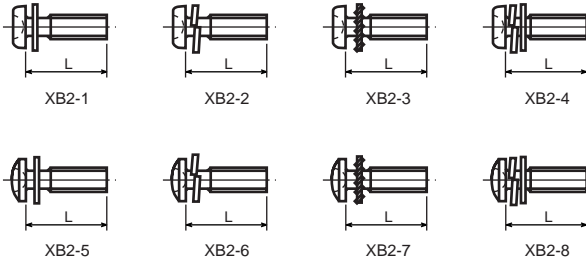

Type No. 類別番号	Type 類別
XB2-1	Pan head + Plain washer (circular bright) なべねじ+平座金
XB2-2	Pan head + Spring washer なべねじ+ばね座金
XB2-3	Pan head + Toothed lock washer なべねじ+歯付座金
XB2-4	Pan head + Spring washer and plain washer (circular bright) なべねじ+(ばね+平)座金
XB2-5	Binding head + Plain washer (circular bright) バインドねじ+平座金
XB2-6	Binding head + Spring washer バインドねじ+ばね座金
XB2-7	Binding head + Toothed lock washer バインドねじ+歯付座金
XB2-8	Binding head + Spring washer and plain washer (circular bright) バインドねじ+(ばね+平)座金

1-5. Hexagon Head Tapping Screws for Metallic Materials
 金属用六角タッピンねじ

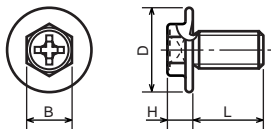

Type No. 類別番号	Type 類別	Head size (mm) 頭部寸法 (mm)	
		M3	M4
XB3-6	For metallic materials 金属用タッピン	D	8 10
		B	5.5 5.5
XB3-7	For metallic materials with clawed 金属用タッピン-つめ付き	H XB3-6	3.1 3.1
		H XB3-7	3.2 3.2

1-6. Special Tapping Screws
 特殊タッピンねじ

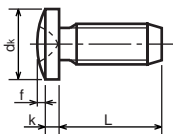

Type No. 類別番号	Type 類別	Head size (mm) 頭部寸法 (mm)	
		M3	M4
XB4-5	Binding head バインド	d _k	6.3 8.3
		k	1.3 1.7
		k+f	1.9 2.5

1-7. General Head Tapping Screws
一般用タッピンねじ

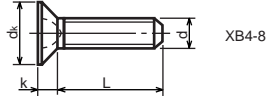
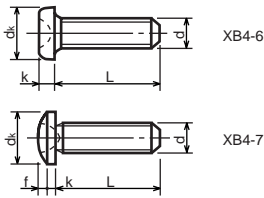

Type No. 類別番号	Type 類別
XB4-6	Pan head なべ
XB4-7	Binding head バインド
XB4-8	Countersunk head さら

		Head size (mm) 頭部寸法 (mm)					
		M2	M2.5	M2.6	M3	M4	M5
d _k	XB4-6	3.5	4.5	4.5	5.5	7	9
k	XB4-6	1.3	1.7	1.7	2	2.6	3.3
d _k	XB4-7	4.3	5.3	5.5	6.3	8.3	10.3
k+f	XB4-7	1.2	1.5	1.6	1.9	2.5	3.1
d _k	XB4-8	4	5	5.2	6	8	10
k	XB4-8	1.2	1.45	1.5	1.75	2.3	2.8

1-8. Tapping Screws for Metallic Materials
金属用タッピンねじ

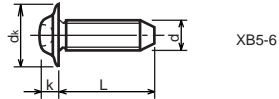
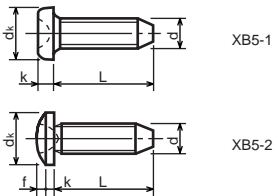

Type No. 類別番号	Type 類別
XB5-1	Pan head なべ
XB5-2	Binding head バインド
XB5-6	Flanged pan head つば付きなべ

		Head size (mm) 頭部寸法 (mm)				
		M2.5	M2.6	M3	M4	M5
d _k	XB5-1	4.5	4.5	5.5	7	9
k	XB5-1	1.7	1.7	2	2.6	3.3
d _k	XB5-2	5.5	5.5	6.3	8.3	10.3
k+f	XB5-2	1.6	1.6	1.9	2.5	3.1
d _k	XB5-6	6.5	6.5	8	10	12
k	XB5-6	2.1	2.1	1.75	3.2	4

1-9. Hexagon Socket Set Screws
六角穴付止めねじ

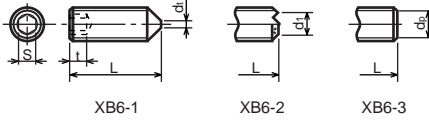

Type No. 類別番号	Type 類別	Head size (mm) 頭部寸法 (mm)							
		M1.6 M1.7	M2	M2.5 M2.6	M3	M5	M5	M6	
XB6-1	Cone point とがり先	S	0.7	0.9	1.3	1.5	2	2.5	3
		t	1.5	1.7	2	2	2.5	3	3.5
		$d_{t \max}$ XB6-1	0.4	0.5	0.65	0.75	1	1.25	1.5
		$d_{l \max}$ XB6-2	-	1.2	1.5	1.7	2.2	2.8	3.3
		$d_{l \min}$ XB6-2	-	1	1.2	1.4	1.9	2.4	2.9
		$d_{p \max}$ XB6-3	0.8	1	1.5	2	2.5	3.5	4
		$d_{p \min}$ XB6-3	0.55	0.75	1.25	1.75	2.25	3.2	3.7

1-10. Flanged Pan Head Machine Screws
つば付きなべ小ねじ

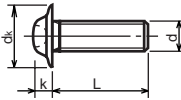

Type No. 類別番号	Type 類別	Head size (mm) 頭部寸法 (mm)					
		M2	M2.5 M2.6	M3	M5	M5	
XB6-7	Flanged pan head つば付きなべ	d_k	5	6.5	8	10	12
		k	1.7	2.1	2.5	3.2	4

FIGURE ZZC MECHANICAL STANDARD PARTS(BOLTS)

2. Bolts (Socket head cap screw) ボルト

How to read Parts Numbers
部品番号の見方

Bolt (Socket head cap screw)
ボルト

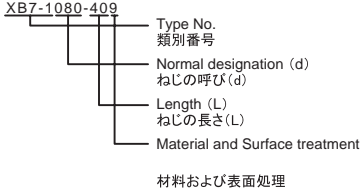

XB7-1 expresses Hexagon socket head cap screws.
XB7-1は、六角穴付きボルトを表す

080 expresses M8.0.
080は、M8.0を表す

40 expresses a length of 40mm.
40は、40mmの長さを表す

9 expresses Steel (Black zinc trivalent chromate
treating) from Table 1.

9は、表1より鋼(黒色亜鉛3価クロメート)を表す

2-1. Hexagon socket head cap screws 六角穴付きボルト

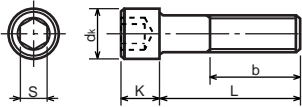

Type No. 類別番号	Type 類別
XB7-1	Hexagon socket head cap screws 六角穴付きボルト

	Head size (mm) 頭部寸法 (mm)						
	M3	M4	M5	M6	M8	M10	M12
S	2.5	3	4	5	6	8	10
d_k	5.5	7	8.5	10	13	16	18
K	3	4	5	6	8	10	12
Screw part length b_{max} ねじ部長さ b_{max}	18	20	22	24	28	32	36

FIGURE ZZD MECHANICAL STANDARD PARTS(NUTS)

3. Nuts ナット

How to read Parts Numbers
部品番号の見方

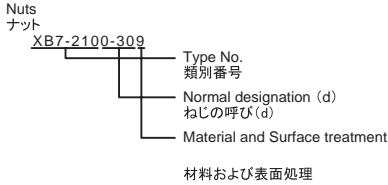

XB7-210 expresses Hexagon nut class 1.
XB7-210は、六角ナット1種を表す

0-30 expresses M3.0.
0-30は、M3.0を表す

9 expresses Steel (Black zinc trivalent chromate
treating) from Table 1.

9は、表1より鋼(黒色亜鉛3価クロメート)を表す

3-1. Hexagon Nuts and Hexagon Thin Nuts 六角ナット

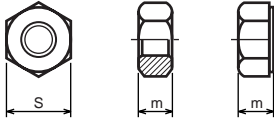

Type No. 類別番号	Type 類別
XB7-210	Hexagon nut Class 1 六角ナット-1種
XB7-220	Hexagon nut Class 3 六角ナット-3種
XB7-230	Hexagon nut Style 1 double chamfered 六角ナット-スタイル1-両面とり
XB7-231	Hexagon nut Style 1 washer faced 六角ナット-スタイル1-座付き
XB7-240	Hexagon nut Style 2 double chamfered 六角ナット-スタイル2-両面とり
XB7-241	Hexagon nut Style 2 washer faced 六角ナット-スタイル2-座付き
XB7-250	Hexagon nut 六角ナット
XB7-260	Hexagon thin nut double chamfered 六角低ナット-両面とり
XB7-270	Hexagon thin nut not chamfered 六角低ナット-面とり無し

	Head size (mm) 頭部寸法 (mm)						
	M2	M2.5	M3	M4	M5	M6	M8
S	4	5	5.5	7	8	10	13
m XB7-210	1.6	2	2.4	3.2	4	5	6.5
m XB7-220	1.2	1.6	1.8	2.4	3.2	3.6	5
m XB7-230, 231	1.6	2	2.4	3.2	4.7	5.2	6.8
m XB7-240, 241	-	-	-	-	5.1	5.7	7.5
m XB7-250	-	-	-	-	5.6	6.1	7.9
m XB7-260	1.2	1.6	1.8	2.2	2.7	3.2	4
m XB7-270	1.2	1.6	1.8	2.2	2.7	3.2	4

FIGURE ZZE MECHANICAL STANDARD PARTS(RETAINING RINGS)

5. Retaining Rings

止め輪

How to read Parts Numbers
部品番号の見方

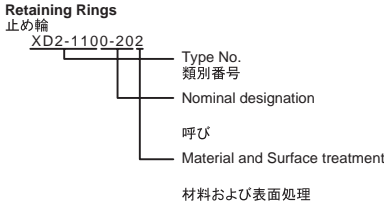

XD2-110 expresses retaining ring-E type (Type1).
XD2-110は、E形止め輪(1種)を表す

0-20 expresses a 020 of nominal designation.
(See Table 5)

0-20は、呼び020を表す(表5参照)

2 expresses Stainless steel (Surface treatment is not to be given) from Table 1.
2は、表1よりステンレス(表面処理なし)を表す

5-1. Retaining Rings - E type

E形止め輪

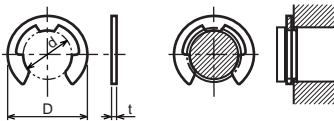

Type No. 類別番号	Type 類別
XD2-110	Retaining ring - E type (Type 1) E形止め輪(1種)
XD2-120	Retaining ring - E type (Type 2) E形止め輪(2種)

Table 5 表5

Type 種類	Nominal designation 呼び	d (mm)	D (mm)	t (mm)
Type 1 1種	007	0.65	2	0.2
	010	0.95	2.8	0.2
	013	1.25	3.3	0.3
	017	1.65	4.2	0.4
	020	1.95	4.6	0.5
	024	2.35	6	0.6
	028	2.74	6.5	0.6
	032	3.14	7.2	0.6
	037	3.64	8	0.7
	040	3.93	10	0.7
	042	4.13	10	0.7
	050	4.93	11	0.7
	058	5.73	12	0.7
	060	5.93	12.7	0.9
	064	6.32	13.5	0.9
	074	7.31	15	0.9
080	7.91	16.5	1	
Type 2 2種	008	0.8	2	0.2
	012	1.2	3	0.3
	015	1.5	4	0.4
	020	2	5	0.4
	025	2.5	6	0.4
	030	3	7	0.6
	040	4	9	0.6
	050	5	11	0.6
	060	6	12	0.8
	070	7	14	0.8
	080	8	16	0.8
	090	9	18	0.8
	100	10	20	1

5-2. Grip Rings
グリップ止め輪

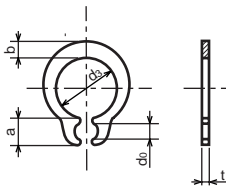

Type No. 類別番号	Type 類別
XD2-210	Grip ring グリップ止め輪

Table 5 表5

Nominal designation 呼び	d ₃ (mm)	t (mm)	b (mm)	a (mm)	d ₀ (mm)
020	1.9	0.5	1	1.8	0.8
025	2.35	0.5	1.2	1.9	0.9
030	2.85	0.6	1.4	1.9	0.9
035	3.3	0.6	1.6	2	0.9
040	3.8	0.8	1.8	2.8	1.2
045	4.25	0.8	2	2.9	1.3
050	4.75	0.8	2.2	2.9	1.3
060	5.7	1	2.4	3.1	1.4
070	6.7	1	2.7	3.3	1.4
080	7.7	1	3	3.5	1.4
090	8.65	1.2	3.3	4.7	1.5
100	9.65	1.2	3.5	4.7	2

5-3. Toothed Retaining Rings
歯付き形止め輪

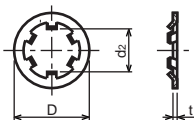

Type No. 類別番号	Type 類別
XD2-230	Toothed retaining ring 歯付き形止め輪

Table 5 表5

Nominal designation 呼び	d _z (mm)	D (mm)	t (mm)	No of teeth 歯数
015	1.4	5.2	0.25	3
020	1.9	6	0.25	3
024	2.3	6.4	0.25	3
030	2.8	8	0.25	4
040	3.8	9	0.25	4
050	4.8	10	0.25	5
060	5.8	11	0.25	5
080	7.8	13	0.25	5
100	9.8	15.4	0.25	6

5-4. Retaining Rings - C Type

C形止め輪

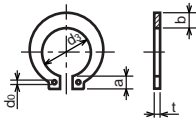

Type No. 類別番号	Type 類別
XD2-310	Retaining ring - C type for shaft C形止め輪 軸用

Table 5 表5

Nominal designation 呼び	d ₃ (mm)	t (mm)	b (mm)	a (mm)	d ₀ (mm)
010	9.3	1	1.6	3	1.2
012	11.1	1	1.8	3.2	1.5
014	12.9	1	2	3.4	1.7
015	13.8	1	2.1	3.5	1.7
016	14.7	1	2.2	3.6	1.7
017	15.7	1	2.2	3.7	1.7
018	16.5	1.2	2.6	3.8	1.7
020	18.5	1.2	2.7	3.9	2
022	20.5	1.2	2.7	4.1	2
025	23.2	1.2	3.1	4.3	2
028	25.9	1.5	3.1	4.6	2
030	27.9	1.5	3.5	4.8	2
032	29.6	1.5	3.5	5	2.5
035	32.2	1.5	4	5.4	2.5

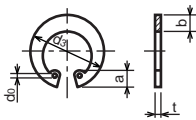

Type No. 類別番号	Type 類別
XD2-320	Retaining ring - C type for hole C形止め輪 穴用

Table 5 表5

Nominal designation 呼び	d ₃ (mm)	t (mm)	b (mm)	a (mm)	d ₀ (mm)
010	10.7	1	1.8	3.1	1.2
011	11.8	1	1.8	3.2	1.2
012	13	1	1.8	3.3	1.5
014	15.1	1	2	3.6	1.7
016	17.3	1	2	3.7	1.7
018	19.5	1	2.5	4	1.7
019	20.5	1	2.5	4	2
020	21.5	1	2.5	4	2
022	23.5	1	2.5	4.1	2
025	26.9	1.2	3	4.4	2
028	30.1	1.2	3	4.6	2
030	32.1	1.2	3	4.7	2
032	34.4	1.2	3.5	5.2	2.5
035	37.8	1.5	3.5	5.2	2.5
037	39.8	1.5	3.5	5.2	2.5
040	43.5	1.8	4	5.7	2.5
042	45.5	1.8	4	5.8	2.5
045	48.5	1.8	4.5	5.9	2.5
047	50.5	1.8	4.5	6.1	2.5
050	54.2	2	4.5	6.5	2.5
052	56.2	2	5.1	6.5	2.5
055	59.2	2	5.1	6.5	2.5
060	64.2	2	5.1	6.8	2.5
062	66.2	2	5.5	6.9	2.5
068	72.5	2.5	6	7.4	2.5
072	76.5	2.5	6.6	7.4	2.5
075	79.5	2.5	6.6	7.8	2.5
080	85.5	2.5	7	8	2.5
085	90.5	3	7	8	3
090	95.5	3	7.6	8.3	3
095	100.5	3	8	8.5	3

Prepared by
L Printer Quality Assurance Center
CANON INC.

Canon