



imageRUNNER ADVANCE C7260

Customer Expectations Document

Version 2



Engineering Services and Solutions Division
Business Imaging Systems Group, Canon U.S.A., Inc.

Contents

1. Introduction	6
2. Product Overview	6
2.1 Summary of Functions	7
2.2 High-Resolution Imaging System for Copied and Printed Images.....	8
2.3 Image Stabilization Control	8
2.3.1 Automatic Gradation Adjustment	8
2.3.2 Real-Time Calibration	8
2.3.3 Accurate Registration	8
2.4 Professional Input/Output Accessories	9
2.5 Storage Capabilities	10
2.5.1 Mail Box.....	10
2.5.2 Advanced Box.....	11
2.5.3 Network.....	11
2.5.4 Memory Media	12
2.6 Security Features	13
2.6.1 Device Authentication	13
2.6.2 Data Security	14
2.6.3 Document Security	17
2.6.4 Network Security.....	18
3. Machine Dimensions and Space Requirements	19
3.1 Dimensions	19
3.2 Weight.....	19
3.3 Installation and Service Space	20
3.3.1 Installation Space Diagrams	20
3.4 Recommended Floor Space Requirements	22
3.5 Floor Structure Requirements	22
3.6 Network Interface Connectivity.....	23
4. Power/Electrical Requirements	24
4.1 Power Requirements for the Main Unit and Optional Accessories	24
5. Environmental Factors and Requirements	26
5.1 Temperature and Humidity Conditions.....	26
5.2 Temperature Gradient.....	26
5.3 Ventilation	27
5.4 Elevation Limitations	27
5.5 Lighting.....	27
5.6 Sunlight	27
5.7 Ammonia.....	27

6. Specifications	28
6.1 Main Unit	28
6.2 Duplex Color Image Reader Unit-F1	30
6.3 Paper Deck Unit-C1	31
6.4 POD Deck Lite-A1	31
6.5 Document Insertion Unit-J1	32
6.6 Document Insertion/Folding Unit-G1	32
6.7 Copy Tray-P1	33
6.8 Staple Finisher-L1	33
6.9 Booklet Finisher-L1	36
6.10 External 2/3 Hole Puncher-A1	39
6.11 Copy Card Reader-F1	39
6.12 Super G3 FAX Board-AD2	40
6.13 Protocol Specifications	40
7. System Options	41
7.1 PCL Printer Kit-AS1	41
7.2 PS Printer Kit-AS1	41
7.3 imagePASS-A2	42
7.4 ColorPASS-GX400	43
7.5 Direct Print Kit (for PDF/XPS Files)-H1	44
7.6 Additional Memory Type D (512 MB)	44
7.7 Super G3 FAX Board-AD2	44
7.8 Super G3 2nd Line Fax Board-AD1	44
7.9 Super G3 3rd/4th Line Fax Board-AE1	44
7.10 Remote FAX Kit-A1	45
7.11 Universal Send Advanced Feature Set-F1	45
7.12 Universal Send Security Feature Set-D1	45
7.13 Universal Send Digital User Signature Kit-C1	45
7.14 Secure Watermark-B1	46
7.15 Document Scan Lock Kit-B1	46
7.16 HDD Data Encryption & Mirroring Kit-C7	47
7.17 Encrypted Secure Print Software-D1	47
7.18 Removable HDD Kit-AH1	47
7.19 2.5inch/160 GB HDD-G1	48
7.20 2.5inch/1 TB HDD-L1	48
7.21 Remote Operator's Software Kit-B1	48
7.22 USB Device Port-A2	48
7.23 Multimedia Reader/Writer-A2	48
7.24 Silex Wireless Bridge SX-2500CG	48
7.25 Web Access Software-H1	49
7.26 Other imageRUNNER ADVANCE C7260 Main Unit Accessory Options	49
8. Installation Review	49
8.1 Installation Time	49
8.2 Customer Installation Responsibilities	51
9. Consumable Items	51
9.1 Usage Conditions	51
9.2 Consumable Parts	52
9.2.1 Estimated Life of Consumables	52
10. Toner Bottle Yields	52

11. Waste Toner Yields	53
12. Optimum Monthly Product Performance	54
13. Machine Productivity	55
13.1 Print Speed	55
13.2 Mixed Paper Weight Job Productivity.....	57
13.3 Paper, Toner, and Waste Toner Replacement.....	57
14. Media Usage/Compatibility	57
14.1 Media Characteristics by Media Library Parameters.....	57
14.2 Paper Handling and Storage	58
14.3 Paper Grain and Curl	59
14.4 Note for Customers Who Cut Their Own Paper	60
14.5 Media Feed Locations	60
14.6 Paper Sizes and Feed Location Chart	66
15. Image Quality Capabilities	68
15.1 Customer-Defined Image Quality Adjustments and Recommendations.....	69
15.1.1 Adjust Image Quality Modes	70
15.1.2 Paper Type Management Settings	70
16. Responsibility Matrix	71

IMPORTANT

The purpose of this Customer Expectations Document is to explain the current features and capabilities of the imageRUNNER ADVANCE C7260, and provide customers information about what to expect before purchasing the machine.

The information included in this document has been pulled from various sources, including product reference guides, service guides, and user manuals, as well as from the results from internal Canon testing. Specifications and other information contained herein may vary slightly, and in a non-material way, from actual device values, including those found in advertising and other printed matter. Part numbers, yield information, and specifications are subject to change without notice. Accordingly, the latest specifications for the machine may not be found in this document. As new information becomes available, this document will be revised. Canon authorized dealers can access the latest revision of this document from the Download Center page in the e-Support Web site (support.cusa.canon.com).

DISCLAIMER

NEITHER CANON NOR ITS SUPPLIERS NOR ANY AUTHORIZED SERVICE PROVIDER SHALL BE LIABLE FOR PERSONAL INJURY OR PROPERTY DAMAGE (UNLESS CAUSED SOLELY AND DIRECTLY BY THE NEGLIGENCE OF CANON OR ANY AUTHORIZED SERVICE PROVIDER), LOSS OF REVENUE OR PROFIT, FAILURE TO REALIZE SAVINGS OR OTHER BENEFITS, EXPENDITURES FOR SUBSTITUTE EQUIPMENT OR SERVICES, LOSS OR CORRUPTION OF DATA, INCLUDING, WITHOUT LIMITATION, DATA STORED ON THE PRODUCT'S HARD DISK DRIVE, STORAGE CHARGES OR OTHER SPECIAL, INCIDENTAL OR CONSEQUENTIAL DAMAGES CAUSED BY THE USE, MISUSE OR INABILITY TO USE THE PRODUCT, REGARDLESS OF THE LEGAL THEORY ON WHICH THE CLAIM IS BASED AND EVEN IF CANON OR ITS SUPPLIERS OR ANY AUTHORIZED SERVICE PROVIDER HAS BEEN ADVISED OF THE POSSIBILITY OF SUCH DAMAGES. NOR SHALL RECOVERY OF ANY KIND AGAINST CANON OR ITS SUPPLIERS OR ANY AUTHORIZED SERVICE PROVIDER BE GREATER IN AMOUNT THAN THE PURCHASE PRICE OF THE PRODUCT CAUSING THE ALLEGED DAMAGE. WITHOUT LIMITING THE FOREGOING, THE PURCHASER ASSUMES ALL RISKS AND LIABILITY FOR LOSS, DAMAGE OR INJURY TO PERSONS AND THE PROPERTY OF THE PURCHASER OR OTHERS ARISING OUT OF THE POSSESSION, USE, MISUSE, OR INABILITY TO USE THE PRODUCT NOT CAUSED SOLELY AND DIRECTLY BY THE NEGLIGENCE OF CANON OR ANY AUTHORIZED SERVICE PROVIDER.

Copyright 2013 by Canon U.S.A., Inc. All rights reserved.

Product and company names used herein are, or may be, the registered trademarks or trademarks of their respective owners.

1. Introduction

The Canon imageRUNNER ADVANCE C7260 Customer Expectations Document contains information about the features and capabilities of the Canon imageRUNNER ADVANCE C7260. This document should be used as part of the presale and pre-installation planning process to help clarify the requirements and responsibilities associated with supporting, owning, and operating the imageRUNNER ADVANCE C7260. It is also recommended that those interested in purchasing the imageRUNNER ADVANCE C7260 have, and familiarize themselves with, the information in this document prior to making their purchase.

2. Product Overview

The Canon imageRUNNER ADVANCE C7260 brings the following capabilities to users in a high-volume office environment and light-production color environment:

- Speeds of up to 60 ppm (pages-per-minute) (LTR, black-and-white), and 55 ppm (LTR, color)
- Single pass duplex document feeder with scanning speeds of up to 200 ipm (images-per-minute) (black-and-white), and 300-sheet capacity as standard
- Large 8.4"SVGA high-resolution TFT screen (800 x 600 pixels) control panel
- Robust finishing options, such as a staple or booklet finisher, an external 2/3 hole puncher, document insertion unit, and paper folding unit
- A maximum paper size of 13" x 19 1/4" is supported. Multiple paper sources, complemented by air-assisted feeding, can hold up to 6,900 sheets of paper for exceptional reliability
- True 1,200 dpi printing at the engine's rated speed
- Standard USB memory support. One USB port is inside the right-corner box and can be used for scanning, printing, or direct printing from a USB memory stick. One USB port is on the rear of the machine, and can only be used to attach a USB keyboard, third-party card reader, direct printing, or for servicing the machine
- New Induction Heating RAPID Fusing Technology for quick warm up times and first copy output times
- Standard Universal Send and UFR II printing
- Micro-Dispersed Pigment Toner Technology – An oil-free toner that uses small particles containing micro-dispersed wax to produce sharp, vivid, dense images, and a smooth finish that looks and feels like offset printing

2.1 Summary of Functions

Function		imageRUNNER ADVANCE C7260
Print Speed (LTR)	B&W	60 ppm
	Color	55 ppm
Scan Speed (LTR, 300 dpi)	Simplex	B&W: 120 ipm, Color: 120 ipm
	Duplex	B&W: 200 ipm, Color: 140 ipm
Scan Speed (LTR, 600 dpi)	Simplex	B&W: 120 ipm, Color: 70 ipm
	Duplex	B&W: 120 ipm, Color: 70 ipm
DADF		Standard Single Pass Duplex
DADF Capacity		300 sheets (20 lb bond (80 g/m ²))
Engine Resolution		1,200 x 1,200 dpi
Gradations		256 levels
Paper Size	Min	5 1/2" x 7 1/8"
	Max	13" x 19 1/4"
Paper Weight	Drawers	14 lb bond to 80 lb cover (52 to 220 g/m ²)
	Multi-Purpose Tray	14 lb bond to 110 lb cover (52 to 300 g/m ²)
HDD Capacity		Standard 160 GB, Maximum 1 TB
Printer Memory		Standard 2 GB RAM, Maximum 2.5 GB RAM
Copy		Standard
Store	Mail Box	Standard
	Advanced Box	Standard
	Memory Media Support	Standard (USB)
Print	UFR II	Standard
	PCL	Optional (w/PCL Printer Kit-AS1-AS1)
	Direct Print	Standard (JPEG, TIFF), Optional (PDF, XPS ^{*1}) (w/PDF/XPS Direct Printer Kit-H1 or PS Printer Kit-AS1-AS1 (PDF only))
	PostScript	Optional (w/PS Printer Kit-AS1-AS1, imagePASS-A2, or ColorPASS-GX400)
	imagePASS (Embedded)	Optional (w/imagePASS-A2)
	ColorPASS (Server)	Optional (w/ColorPASS-GX400)
Send	Universal Send	Standard
	PDF High Compression	Standard
	PDF Advanced Feature Set	Optional
	PDF Security Feature Set	Optional
	PDF Digital User Signature	Optional
Fax	Super G3 Fax	Optional (up to 4 lines w/Super G3 FAX Board)
Network		Standard Ethernet 10 Base-T/100 BaseTX/1000 Base-T, Optional Wireless LAN
Remote UI		Standard
MEAP Capability		Standard
Access Management System		Standard

*1 Direct Print XPS files can only be printed from the Remote UI.

2.2 High-Resolution Imaging System for Copied and Printed Images

The imageRUNNER ADVANCE C7260 provides a high-resolution imaging system. This system renders images at a 1,200 x 1,200 dpi print resolution, which delivers the highest level of speed and image quality. Object-optimized imaging also helps to achieve superior print quality. Text and lines are processed with a high priority given to resolution, and images and graphics are processed with a high priority given to gradation. This high-resolution imaging system coupled with the Density Fine Adjustment mode, a feature that refines thin, fine text, and lines while the device is rendering images at 1,200 x 1,200 dpi, minimizes faint output and delivers quality prints.

2.3 Image Stabilization Control

The quality of printed images is affected by changes in the environment, such as temperature and humidity, in which the machine is installed. It is also affected by the deterioration of image formation parts through extended use. The imageRUNNER ADVANCE C7260 overcomes these issues, stabilizes image production, and maintains color consistency with features, such as Auto Gradation Adjustment, Real-Time Calibration, and accurate registration.

2.3.1 Automatic Gradation Adjustment

Automatic Gradation Adjustment is a function that helps to automatically adjust toner density. Select from the Quick Adjustment mode or Full Adjustment mode. The Quick Adjustment mode quickly and simply adjusts the gradation, density, and color by performing calibration without outputting test prints. The Full Adjustment mode performs a precise calibration by outputting and scanning test prints. For more information on the Automatic Gradation Adjustment modes, see “Adjustment/Maintenance,” in the *Settings/Registration e-Manual* included with the machine.

2.3.2 Real-Time Calibration

Real-Time Calibration helps to maintain color consistency by making automatic, real-time adjustments during print runs. Density level measurements of cyan, magenta, yellow, and black toner are taken every 100 pages during a print job. The patches of each color are imaged on the ITB (Intermediate Transfer Belt), and sensors measure the density to adjust the toner gradation and density.

2.3.3 Accurate Registration

Image registration can be finely adjusted by manually specifying an exact adjustment value for every user-specified paper type. For more information, see “Printing a Test Page to Adjust the Image Position on a Custom Paper Type,” in the *Settings/Registration e-Manual* included with the machine.

2.4 Professional Input/Output Accessories

The imageRUNNER ADVANCE C7260 features many robust input and output accessories that allow customers working in light-production, graphic arts or highly productive office environments to complete large jobs directly from the machine. For more information on the input and output accessories that can be attached to the machine, see [“Specifications.”](#) on p. 28.

Input Accessories

- Duplex Color Image Reader Unit-F1 (Standard)
- Paper Deck Unit-C1
- POD Deck Lite-A1

Finishing (Output) Accessories

- Staple Finisher-L1
- Booklet Finisher-L1
- External 2/3 Hole Puncher-A1
- Document Insertion Unit-J1 or Document Insertion/Folding Unit-G1

2.5 Storage Capabilities

The imageRUNNER ADVANCE C7260 offers four built-in storage methods with flexible linkage to external systems for storing scanned documents and accessing stored files.

- Mail Box
- Advanced Box
- Network
- Memory Media



IMPORTANT

- Canon U.S.A., Inc. is not responsible for any damages caused to user data that is stored on the hard disk drive of the machine. It is the customer's responsibility to create and maintain a data backup plan. Canon U.S.A., Inc. offers several security options to enhance document handling and storage security needs. See ["System Options."](#) on p. 41.
- It is strongly recommended to back up the data stored on the hard disk drive.

2.5.1 Mail Box

The Mail Box is a data storage area that stores and handles files for printing.

The Mail Box function enables users to store files that are scanned with this machine, or data sent from a personal computer via the printer driver. The stored files can be printed anytime using the desired settings. Also, the file format of the scanned documents can be converted into another format, such as TIFF, PDF, XPS, and JPEG, to send via e-mail or fax by using the Send function. Up to 100 mailboxes can be used, and a name or password can be set for each mailbox. In addition, various editing features are available, such as merging separately stored files into one file, and erasing unnecessary pages from a file.

2.5.2 Advanced Box

Advanced Box is a storage area in the machine that stores scanned documents and Microsoft Office files that can be used on a computer. There are two types of storage in the Advanced Box: the Shared Space and the Personal Space.

Shared Folders

- An open access storage space. Ideal as a shared storage space by multiple users (for example, team, group, or department members).
- Subfolders can be created.
- Up to 1,000 files/folders (main and sub) can be saved in each level.

Personal Folders

- Access is restricted to the set user only. Authentication must be set up to enable a personal folder.
- Subfolders can be created.
- Up to 1,000 files/folders (main and sub) can be saved in each level.

Documents can be scanned with this machine, stored in the PDF, XPS, JPEG, or TIFF file format, and can also be previewed or printed on this machine at any time with the desired print settings.

The Advanced Box can be opened to the public as an SMB (Server Message Block) server or WebDAV (Distributed Authoring and Versioning) server. This enables the user to access the Advanced Box from a computer, and store and share files in their native format, such as MS Word, Excel, and PowerPoint. To view and print these native format files from the Advanced Box, the user must access them via a computer.

The standard storage space for the Advanced Box is approximately 15 GB. However, the standard Advanced Box storage capacity can be increased to 629 GB if the optional 2.5inch/1 TB HDD is installed.



IMPORTANT

It is strongly recommended to protect the Advanced Box folders from viruses. If the user's computer system has an antivirus system in place, add the Advanced Box folders to its list of folders to scan and protect.

2.5.3 Network

The imageRUNNER ADVANCE C7260 is equipped with a collaboration function that enables it to be connected to other imageRUNNER ADVANCE machines via the SMB/WebDAV protocol. When the machine is connected to other machines, a user can select an Advanced Box in another machine (if it is on the network) to store files or print a file that is stored in another machine on this machine.

2.5.4 Memory Media

Memory Media is storage that can be used by attaching a USB memory stick to the USB port on the control panel. A document can be scanned with this machine and stored in memory media in the PDF, XPS, JPEG, or TIFF file format, and also the file stored in the memory media can be printed on this machine at any time with the desired print settings.

If the optional USB Device Port-A2 and Multimedia Reader/Writer-A2 are installed, an SD card, Memory Stick, Compact Flash card, and Microdrive can be used. For more information, see ["USB Device Port-A2,"](#) on p. 48, and ["Multimedia Reader/Writer-A2,"](#) on p. 48.

2.6 Security Features

The imageRUNNER ADVANCE C7260 includes a comprehensive set of security features, such as Device Authentication, Data Security, Document Security, and Network Security.

2.6.1 Device Authentication

There are two ways to authenticate users at the device.

- **Department ID Management** - Register a Department ID and password for each department, and manage the machine by limiting its use to only those who enter the correct Department ID and password. Department IDs and passwords for up to 1,000 departments can be registered. Use Department ID Management to keep track of the copy, scan, and print totals for each department. The following settings can be specified:
 - Turn Department ID Management 'On' or 'Off'.
 - Register the Department ID and password.
 - Set page limits for scans, prints, and copies.
 - Set whether to use Department ID Management for the Mail Box, Send, and Network Scan functions. If the Copy function is specified, it is automatically restricted when Department ID Management is set.
 - Set up copy, scan, and print restrictions.
- **SSO-H (Single Sign-On H)** - A user authentication system that enables the functions of the machine and MEAP applications, etc., to be used after being authenticated once. SSO-H has two compatible user authentication systems (Domain Authentication and Local Device Authentication). Domain Authentication is linked to a domain controller in a Windows Active Directory environment on a network. Local Device Authentication uses a database inside the machine to authenticate users. Administrators can use one of these two systems or both at the same time. The Access Management System is a subset of the SSO-H authentication system.
- **Access Management System** - The standard AMS (Access Management System) allows system administrators to restrict various Copy, Print, Fax, Scan, Mail Box, and Send functions that each user can use. Once the AMS is activated, a Function Level Log-In can be used to authenticate users for specific machine features only. SSO-H must be activated to use the Log-In feature for the AMS.

2.6.2 Data Security

The imageRUNNER ADVANCE C7260 offers several ways to protect and secure data. It is strongly recommended that a back up and security system is in place, along with an antivirus protection system to make sure that no data on the hard disk drives is lost, stolen, or compromised.

CAUTION

Canon U.S.A., Inc. is not liable for any damages resulting from the loss or corruption of data. (See page 5 for further details.)

- **Document Scan Lock Kit-B1** - The optional Document Scan Lock Kit-B1 embeds a code all over a printed document, which identifies which printer printed the document, and enables the user to track who printed the document. The Document Scan Lock system is tamper resistant, and if someone tries to copy the document, the Document Scan Lock system checks to see if the person has the proper permissions to reproduce it. A password may be required to enable the reproduction of the document. For more information on the Document Scan Lock Kit-B1, see ["Document Scan Lock Kit-B1,"](#) on p. 46.

- **TPM (Trusted Platform Module)** - TPM is a standard security chip (tamper resistant hardware) installed in the imageRUNNER ADVANCE C7260. The TPM provides a facility for the secure generation of cryptographic keys, encrypts information stored on the internal HDD, and decrypts information read from the internal HDD. The public keys to encrypt confidential information are securely controlled by the TPM chip, and they can only be decrypted if the TPM releases the associated decryption key. If the HDD is removed from the machine, it will be difficult to retrieve data off that HDD since the encryption key for that data is stored in a separate location within the TPM.

CAUTION

Once the TPM setting is activated, if the end user fails to back up the TPM key, or if the end user loses the TPM key, it may result in permanent, unrecoverable data loss, for which Canon U.S.A., Inc. is not liable. (See page 5 for further details.)



IMPORTANT

- If the TPM setting is activated and the TPM chip fails, the confidential information stored on the chip can only be recovered if Canon's service representative replaces the TPM chip and restores the original TPM key to the new chip. Immediately, back up the TPM key on a USB memory stick, after the TPM setting is activated.
 - Only the Administrator of the machine can back up the TPM key.
 - For security reasons, the TPM key can only be backed up once. Store the USB memory with the backup data in a safe place.
 - For the back up of the TPM key, it is recommended that a USB memory stick (supported system file: FAT32) with free space of 10 MB or more is used.
 - The TPM seals the hardware components associated with the data, and the data cannot be accessed unless the specific TPM key is issued by the TPM chip. Therefore, setting the TPM mode to 'On,' may affect service procedures and service costs (if not handled properly). It is strongly recommended that the Administrator who has access to the TPM key be present for all service calls to prevent the loss of data and productivity of the machine.
-
- **Removable HDD Kit-AH1** - The optional Removable HDD Kit-AH1 provides the capability to physically remove the hard disk drive out of the machine and place it in a secured location. The hard disk drive can easily be removed for secure storage on a frequent basis, and can easily be reinstalled for normal machine use. This option provides another layer of data security for government agencies and corporate enterprises that need to ensure that data stored on the hard disk is physically secure when the machine is not in use. For more information on the Removable HDD Kit-AH1, see ["Removable HDD Kit-AH1,"](#) on p. 47.

- **HDD Data Erase** - The standard HDD Data Erase feature is available for those environments requiring additional data security measures. This feature automatically overwrites image data that is written to the hard drive following each job performed at the machine. The HDD Data Erase feature overwrites up to three times with random data, depending on the preferences set by the system administrator. Other settings include the ability to overwrite once with null data and overwrite once with random data.



IMPORTANT

An increase in the amount of times the HDD Data Erase feature overwrites data, may result in a loss of job productivity.

- **HDD Data Encryption & Mirroring Kit-C7** - The optional HDD Encryption & Mirroring Kit-C7 is another security tool available for environments requiring additional data security measures, and can be used in conjunction with the HDD Data Erase feature to provide even greater security for data stored on the internal HDD. The HDD encryption chip is Common Criteria Certified (EAL level 3), and applies 256-bit AES (Advanced Encryption Standard) encryption to all data prior to being written on the HDD. This adds an additional layer of security to files stored on the HDD. The Mirroring function provides redundancy when utilized with an additional hard disk drive of the same storage capacity. This preserves company data if one hard disk drive fails. For more information on the HDD Data Encryption & Mirroring Kit-C7, see [“HDD Data Encryption & Mirroring Kit-C7,”](#) on p. 47.

2.6.3 Document Security

The imageRUNNER ADVANCE C7260 offers several document security modes to protect printed and distributed documents.

- **PDF Visible Digital Signature** - The PDF Visible Signatures mode enables the user to view the device signature and user signature on a PDF file. Visible digital signatures and user signatures are displayed on the first page of the PDF file to account for the origin of the document. The system administrator of the machine can set the Visible Signatures mode for all PDF documents or certain PDF documents created on the machine. This mode differentiates from the Digital Signature mode in that instead of having to access digital signature information from the document properties from the File menu, this information is displayed prominently on the first page of the document in the background, and is printed along with the document data, thereby deterring improper distribution of sensitive documents.
- **Adobe LiveCycle Rights Management ES Server Integration** - Adobe LiveCycle enables Administrators to set automatic document privileges and apply security policies by creating Policy Protected PDF files on the machine, even after document creation, using the Adobe LiveCycle Rights Management ES Server. Once a Policy Protected PDF document is created on the machine with this feature enabled, the PDF extension in Adobe Reader, upon attempt by a user to open a protected PDF, contacts the Rights Management Server to check the latest authorized users, expiration, auditing, and watermarking policies set by the administrator. These latest policies are then enforced by that application to ensure the information in that document remains secure.



IMPORTANT

- To generate a PDF linked with Adobe LiveCycle Rights Management ES Server, the Adobe LiveCycle Rights Management ES Server must be licensed, pre-configured by a system administrator, and the machine must be connected to the Intranet or Internet.
- Encrypted PDF and PDF/A-1b documents are not compatible with Adobe LiveCycle Rights Management ES Server.

2.6.4 Network Security

The imageRUNNER ADVANCE C7260 secures network communications by using IP Address and MAC (Media Access Control) Address filters, encryption and authentication, and network port and application access control.

- **IP Address and MAC Address Filters** - IP Address Filter performs a function similar to many firewalls. It permits or rejects incoming packets from up to eight IP addresses or ranges of IP addresses. Also, IP address filters to outbound connections can be applied. For example, if such functions as Remote Copy and Universal Send are used, system administrators can block or restrict users from sending files to specific IP addresses. This helps to minimize the risk of data being sent out of the company to systems that are not trusted.

MAC Address Filter permits or rejects access for up to 100 MAC addresses. It is useful for environments that use DHCP (Dynamic Host Configuration Protocol) for IP address assignments. If DHCP leases expire and a new IP address is issued to a certain system, the filter can still identify the system's MAC address, and permit or reject access to the machine. MAC addresses can be easily added, edited, or deleted through the Remote UI. MAC Address Filter takes a higher priority than IP Address Filter, which prevents unknown systems from attacking the machine.

- **Encryption and Authentication** - SSL (Secure Sockets Layer) protects data transferred over the network by encrypting file names and formats. The System Administrator can also add IPSec capabilities to secure Internet Protocol (IP) communications from lower layer protocols, such as TCP (Transmission Control Protocol) and UDP (User Datagram Protocol) by authenticating and encrypting each IP packet of a data stream across the Internet.

Additionally, the imageRUNNER ADVANCE C7260 supports IEEE 802.1x, which provides port-based authentication. Authentication involves communications between a supplicant, authenticator, and authentication server. The supplicant is authentication software on a client device. The client device (the imageRUNNER ADVANCE C7260) needs the supplicant to provide credentials, such as user names/passwords or digital certificates, to the authenticator (a wireless access point). The authenticator then forwards the credentials to the authentication server (generally a RADIUS database) for verification. If the credentials are valid in the authentication server database, the client device is allowed to access resources located on the protected side of the network.

- **Network Port and Application Access Control** - Network Port and Application Access Control enables system administrators to set up only the necessary protocols, such as IPP, FTP, SNT, SNMP, RAW, LPD, and others for transferring data. These protocols can be switched on and off. The administrator can also disable unneeded services, protocols, ports, and the potential paths of attack so that attacks on the machine can be minimized.

3. Machine Dimensions and Space Requirements

3.1 Dimensions

The following table includes the width, height, and depth dimensions (in inches and millimeters) of the main unit and optional accessories.

Unit	Width		Depth		Height	
Main Unit w/Duplex Color Image Reader Unit-F1	27.1"	689 mm	36.75"	932 mm	48.1"	1,221 mm
Buffer Pass Unit-J1	7.0"	178 mm	25.0"	635 mm	40.0"	1,016 mm
POD Deck Lite-A1	23.6"	601 mm	24.5"	621 mm	22.4"	570 mm
Paper Deck Unit-C1	12.75"	323 mm	23.0"	583 mm	22.4"	570 mm
Document Insertion Unit-J1	26.1"	662 mm	26.75"	679 mm	48.9"	1,242 mm
Document Insertion/Folding Unit-G1	26.1"	662 mm	26.75"	679 mm	48.9"	1,242 mm
Staple Finisher-L1 ^{*1}	30.0"	761 mm	25.9"	656 mm	44.1"	1,121 mm
Booklet Finisher-L1 ^{*2}	30.0"	761 mm	25.9"	656 mm	44.1"	1,121 mm
External 2/3 Hole Puncher-A1	4.25"	107 mm	24.25"	615 mm	32.5"	825 mm
Copy Tray-P1	16.5"	420 mm	15.0"	382 mm	6.9"	175 mm
Copy Card Reader-F1 ^{*3}	3.5"	88 mm	3.75"	96 mm	1.6"	40 mm

*1 The auxiliary tray is extended. If the auxiliary tray is not extended, the width is 25.4" (644 mm).

*2 The auxiliary tray is extended. If the auxiliary tray is not extended, the width is 25.5" (646 mm)

*3 The attachment kit and cable are not included.

3.2 Weight

The approximate weights of the main unit, feeder, and finishing options (in pounds and kilograms) are listed in the table below.

Unit	Weight	
Main Unit w/ Duplex Color Image Reader Unit-F1, Buffer Pass Unit-J1, and Toner	604 lb	274 kg
POD Deck Lite-A1	110 lb	50 kg
Paper Deck Unit-C1	81.6 lb	37 kg
Document Insertion Unit-J1	88.2 lb	40 kg
Document Insertion/Folding Unit-G1	168 lb	76 kg
Staple Finisher-L1	106 lb	48 kg
Booklet Finisher-L1	158.7 lb	72 kg
External 2/3 Hole Puncher-A1	17 lb	7.7 kg
Copy Tray-P1	2.9 lb	1.3 kg
Copy Card Reader-F1 ^{*1}	7.1 oz	0.2 kg

*1 The attachment kit and cable are included.

3.3 Installation and Service Space

The installation site must provide enough space for unrestricted operation, maintenance work, and proper ventilation. The machine dimensions are in diagrams on the following pages. Every attempt should be made to install the equipment in a room that allows for the proper servicing and maintenance of the equipment, and ensures that issues, such as ventilation, odors, and dust accumulation are not a concern.



IMPORTANT

- Keep the back of the machine at least 4" (100 mm) away from a wall.
- Make sure that approximately 19 3/4" (500 mm) of space is left around the front, left, and right sides of the machine for the proper servicing of the equipment.
- The floor must be level (with no bows) and flat for the stabilization and support of the machine.
- The minimum doorway opening that the machine passes through prior to installation must be at least 36" wide.
- The machine should not be moved once it is in place.

3.3.1 Installation Space Diagrams

The approximate installation space requirements may differ, depending on how the machine is configured and the optional accessories attached.

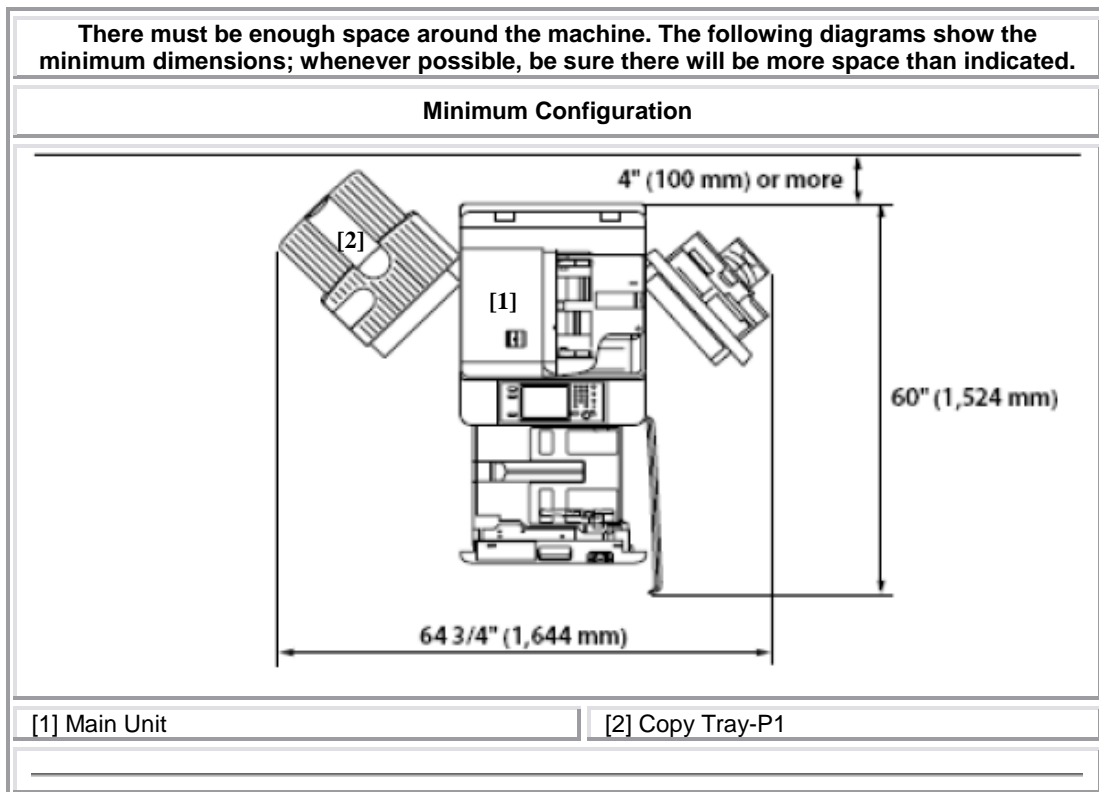

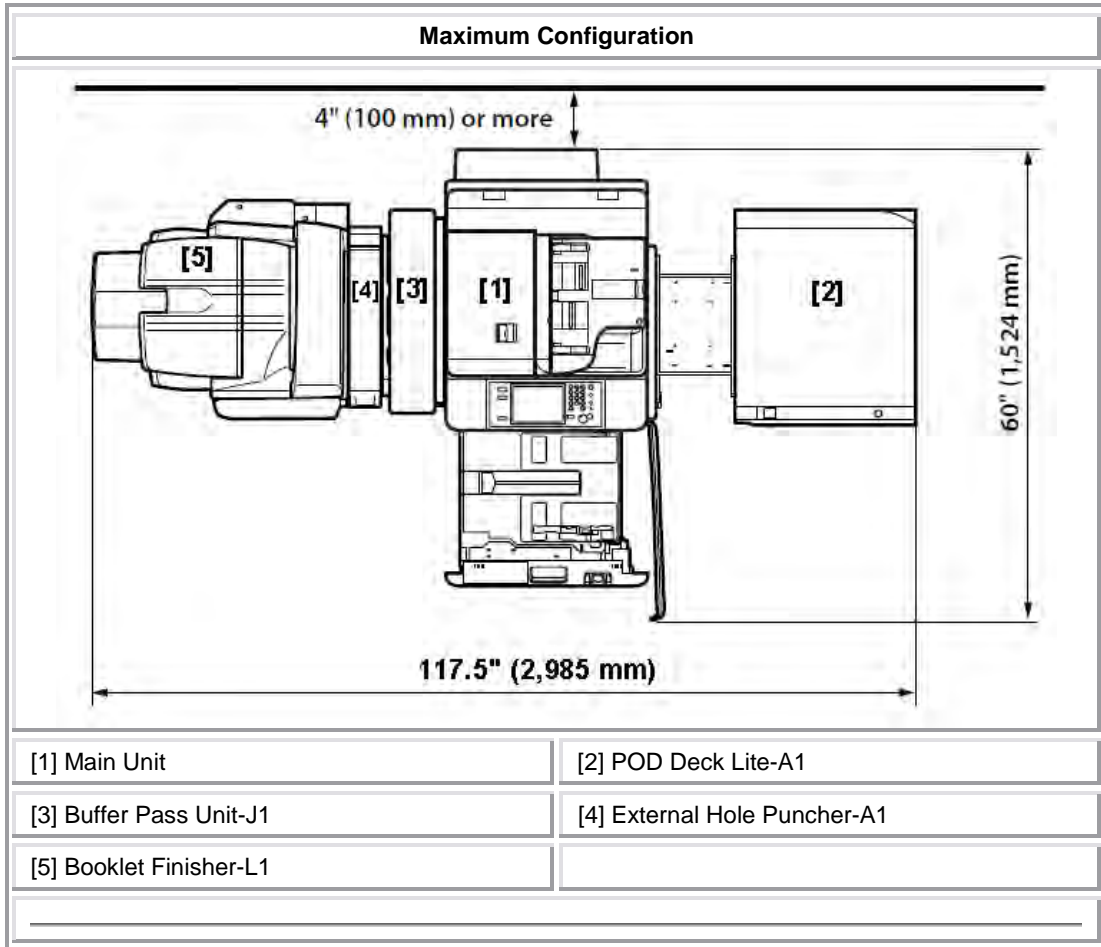

IMPORTANT

- The maximum configuration (fully configured machine) includes the Duplex Color Image Reader Unit-F1, Buffer Pass Unit-J1, POD Deck Lite-A1, Document Insertion/Folding Unit-G1, and Booklet Finisher-L1.
- The fully configured width of the machine includes opening space for the POD Deck Lite-A1 and the extended tray of the Booklet Finisher-L1.
- There needs to be approximately 1/5" (5 mm) of space in between each accessory attached.

3.4 Recommended Floor Space Requirements

For a fully configured imageRUNNER ADVANCE C7260, it is recommended that there be at least 13.1' (W) x 7' (D) of level floor space.

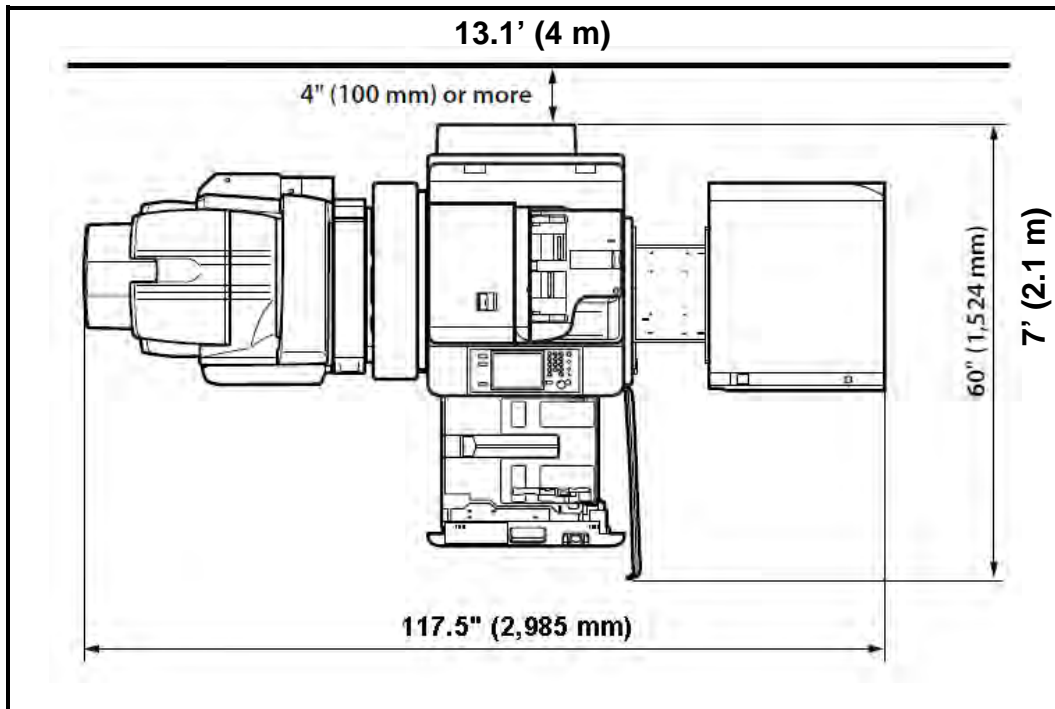

IMPORTANT

- The imageRUNNER ADVANCE C7260 was created to be modular in design. Floor space, budget, monthly copy/print volume, and applications will determine which configuration will work best.
- Only one optional finisher unit (Staple Finisher-L1 or Booklet Finisher-L1) can be attached to the machine.
- Only one optional insertion unit (Document Insertion Unit-J1 or Document Insertion/Folding Unit-G1) can be attached to the machine.
- Only one optional paper feeding unit (POD Deck Lite-A1 or Paper Deck Unit-C1) can be attached to the machine.

3.5 Floor Structure Requirements

The floor on which this machine is installed must have strength of at least 61.5 lb/ft² (300 kg/m²). If the floor does not have this level of strength, consult a building contractor before installing the machine.

The weight of the machine is distributed on the floor through the adjusters and wheels. Do not install the machine on an unstable floor or platform.

3.6 Network Interface Connectivity

A standard Ethernet 10/100/1000 Base-TX interface jack (RJ-45) for device installation, monitoring, Mail Box and Advanced Box access via the Remote UI, ships standard with all configurations. A Wireless LAN connection can be obtained with the optional Silex Wireless Bridge SX-2500CG. (See [“Silex Wireless Bridge SX-2500CG,”](#) on p. 48.

Standard support for up to two USB 2.0 High-Speed interface ports ships standard with all configurations. One USB port is inside the right-corner box and can be used for scanning, printing, or direct printing from a USB memory stick. One USB port is on the rear of the machine, and can only be used to attach a USB keyboard, third-party card reader, direct printing, or for servicing the machine.

4. Power/Electrical Requirements

The imageRUNNER ADVANCE C7260 requires a NEMA 5-20 receptacle for the main unit.



NEMA 5-20 Receptacle

4.1 Power Requirements for the Main Unit and Optional Accessories

Part or Accessory	Power Supply	Power Supply Cord/Plug Specifications	Length of Power Cord
Main Unit	1-120 V/20 A outlet	NEMA 5-20	8' (2.4 m)
POD Deck Lite-A1	1-120 V/15 A outlet	NEMA 5-15	8' (2.4 m)
Document Insertion Unit-J1	1-120 V/15 A outlet	NEMA 5-15	6' (1.8 m)
Document Insertion/Folding Unit-G1	1-120 V/15 A outlet	NEMA 5-15	6' (1.8 m)
imagePASS-A2	1-120 V/15 A outlet	NEMA 5-15	6' (1.8 m)
ColorPASS-GX400	1-120 V/15 A outlet	NEMA 5-15	6' (1.8 m)

The following illustration shows the power outlets and voltage requirements of each optional accessory item.



IMPORTANT

- We recommend an additional standard 120 V/15 A outlet for service tools, such as a laptop computer or vacuum that may be used when servicing or configuring the machine.
- Use only dedicated and properly grounded outlets for the main unit and ColorPASS or imagePASS. It is also strongly suggested to use dedicated and properly grounded outlets for each optional accessory. Do not use extension cords. The ground connection serves to provide the internal electronics with a reference voltage. Faulty or poor ground sources will cause this reference voltage to fall into a range that no longer serves as a reliable reference voltage. The internal logic and programming of the imageRUNNER ADVANCE C7260 will not perform reliably because there is an insufficient difference between the internal operating signal voltages and the poor ground reference signal. A qualified electrician can measure and provide the ground source that the imageRUNNER ADVANCE C7260 or any computer controlled office equipment requires.
- Before installation, confirm that all necessary receptacles are available.

NOTE

The Duplex Color Image Reader Unit-F1, Paper Deck Unit-C1, External 2/3 Hole Puncher-A1, Staple Finisher-L1, and Booklet Finisher-L1 do not require any additional outlets.

5. Environmental Factors and Requirements

This section describes the necessary environmental factors and requirements in which the machine should be operated to achieve the best image quality and print results.



NOTE

It may be necessary to use a humidifier or dehumidifier to attain the proper humidity levels for optimal machine performance.

5.1 Temperature and Humidity Conditions

The optimal humidity range is 30% to 70% RH (Relative Humidity) with a room temperature of 68°F to 80.6°F (20°C to 27°C).

The machine contains intelligent technology that can sense the environmental temperature, and optimize its performance if operated outside the temperature range. However, productivity, paper feeding, and image quality may be affected if the machine is operated outside of these guidelines.

The machine should not be installed in locations with significant shifts in temperature or humidity. Areas containing water, or equipment that can significantly alter room temperature or humidity, such as a heater, stove, or portable air conditioner, should be avoided, unless proper environmental control is available to achieve maximum productivity or quality capability.

The optimal humidity range for storing paper is 30% to 70% RH (Relative Humidity) with a room temperature of 68°F to 80.6°F (20°C to 27°C). Storing paper in a location that does not meet these specifications may affect paper feeding and image quality. For example, if the humidity is too high, paper curling and paper jams will increase. If the humidity is too low, paper may shrink or lose resistance, and toner will not adhere to the paper as well.

5.2 Temperature Gradient

Using an air conditioner during the winter, or if a sudden temperature change occurs, may have an adverse affect on image positioning. Sudden temperature changes may cause the paper to bend or contract, cause the machine to malfunction, and form condensation. To avoid these issues, control the temperature gradient so that temperature fluctuations do not exceed 18°F per hour or 10°C per hour.

5.3 Ventilation

Ensure that there is an air exchange rate of at least 1.5 times per hour, and at least 3,885 ft³ (110 m³) of space in the location where the machine will be installed.

This machine generates a slight amount of ozone during normal use. Although sensitivity to ozone may vary, this amount is not harmful. Ozone may be more noticeable during extended use or long production runs, especially in poorly ventilated rooms. It is recommended that the room be appropriately ventilated, sufficient to maintain a comfortable working environment, in areas of machine operation.

5.4 Elevation Limitations

Install this machine at an elevation below 13,123' (4,000 m) and at an air pressure less than 607.8 hPa.

5.5 Lighting

We recommend installing the machine in a location with at least 500 lux (29 1/2" (75 cm) above the floor) for normal operation and maintenance.

5.6 Sunlight

Avoid installing the machine in direct sunlight. Direct sunlight has adverse effects on toner consistency and image quality. If direct sunlight is unavoidable, use curtains to shade the machine. Be sure that the curtains do not block the machine's ventilation slots or louvers, or interfere with the electrical cord or power supply.

5.7 Ammonia

Avoid installing the machine where ammonia is emitted. In a sufficient amount, ammonia will attack the surfaces of the machine's paper feed and image quality components, thereby shortening their useful life and increasing the need for periodic and remedial maintenance.

A professional assessment of the air quality in the room in which the machine is to be installed is recommended prior to its installation.

6. Specifications

This chapter explains the specifications of the main unit and optional accessories.

The specifications provided are approximate values for reference only, and are subject to change without notice for product improvement or future release.

6.1 Main Unit

Item	Specifications
Name	Canon imageRUNNER ADVANCE C7260 PRO
Type	Reader-, Printer-Separated Console
Developing System	Dry Dual Component Toner Projection
Color Supported	Full Color
Engine Resolution	Up to 1,200 dpi x 1,200 dpi
Number of Gradations	256
Memory	2GB RAM (Standard), 2.5 GB (Maximum)
Hard Disk	160 GB (Standard), 1 TB (Maximum)
Paper Weight and Type	<p>Paper Drawers 1 and 2:</p> <p>Weight: 14 lb bond to 80 lb cover (52 to 220 g/m²)</p> <p>Type:^{*1} Thin, Plain 1, Plain 2, Heavy 1, Heavy 2, Color, Recycled, Pre-Punched, Transparency, Bond, and Letterhead</p> <p>Paper Drawers 3 and 4:</p> <p>Weight: 14 lb bond to 80 lb cover (52 to 220 g/m²)</p> <p>Type:^{*1} Thin, Plain 1, Plain 2, Heavy 1, Heavy 2, Color, Recycled, Pre-Punched, Transparency, Tab, Bond, and Letterhead</p> <p>Multi-Purpose Tray:</p> <p>Weight: 14 lb bond to 110 lb cover (52 to 300 g/m²)</p> <p>Type:^{*1} Thin, Plain 1, Plain 2, Heavy 1, Heavy 2, Heavy 3, Heavy 4, Color, Recycled, Pre-Punched, Transparency, Tracing, Labels, Bond, Letterhead, Coated, Textured, and Envelopes</p> <p>^{*1} For detailed supported paper weights, see "Media Feed Locations." on p. 60.</p>
Paper Size	<p>Paper Drawers 1 and 2: LTR</p> <p>Paper Drawers 3 and 4: 13" x 19", 12 5/8" x 17 11/16", 12" x 18", 11" x 17", LGL, LTR, LTRR, EXEC, STMTR, Custom Size (5 1/2" x 7 1/8" to 13" x 19 1/4" (139.7 mm x 182 mm to 330.2 mm x 487.7 mm))</p> <p>Multi-Purpose Tray: 13" x 19", 12 5/8" x 17 11/16", 12" x 18", 11" x 17", LGL, LTR, LTRR, EXEC, STMTR, Custom Size (4" x 5 7/8" to 13" x 19 1/4" (100 mm x 148 mm to 330.2 mm x 487.7 mm)), and Envelopes</p>

Main Unit Table Continued

Item		Specifications		
Margin		Top Margin: 1/8" (2.5 mm) Left and Right Margins: 1/8" (2.5 mm) Bottom Margin: 1/8" (2.5 mm)		
Warm-Up Time		After Powering ON: Up to 31 seconds Returning from the Sleep mode: Up to 30 seconds Quick Startup ^{*1} : Up to 7 seconds ^{*1} Quick Startup settings for main power is set to 'On'. If the hard disk capacity is 1 TB, the warm-up time becomes longer in the Quick Startup mode. Activation time may vary, depending on the environment and conditions under which the machine is being used.		
First Copy Output Time		Full Color: 6.6 seconds ^{*1} Black-and-White: 4.9 seconds ^{*2} ^{*1} When 'Color Priority' is selected. ^{*2} When 'Black Priority' is selected.		
Copy Speed (20 lb bond (80 g/m²)) (Except When paper Is Fed from the Multi-Purpose Tray)		Direct (sheets/minute)	Black-and-White	Color
		13" x 19"	27 ^{*1}	25 ^{*1}
		12 5/8" x 17 11/16"	29 ^{*1}	26 ^{*1}
		12" x 18"	28 ^{*1}	26 ^{*1}
		11" x 17"	30	28
		LGL	36	33
		LTR	60	55
		LTRR	45	41
		EXEC	60	55
		STMTR	60	55
		^{*1} The copy speed may become slow just after starting copying. When copying continuously, adjustments for machine temperature or image quality may cause machine operations to pause or become slow.		
Paper Feeding System/ Capacity		Paper Drawers 1 and 2: 1,100 sheets x 2 drawers (20 lb bond (80 g/m ²)) Paper Drawers 3 and 4: 550 sheets x 2 cassettes (20 lb bond (80 g/m ²)) Multi-Purpose Tray: 100 sheets (20 lb bond (80 g/m ²))		
Multiple Copies		1 to 9,999 sheets		
Noise Level	During Operation	B&W Printing: Approximately 7.4 B or less (Sound Power) Color Printing: Approximately 7.4 B or less (Sound Power) B&W Printing: Approximately 57 dB or less (Sound Pressure) Color Printing: Approximately 57 dB or less (Sound Pressure)		
	During Standby	Approximately 5.3 B or less (Sound Power) Approximately 35 dB or less (Sound Pressure)		
Ozone Emissions		0.01 ppm (parts per million) or less (Initial Startup) 0.035 ppm or less (After a short break-in period)		
Power Source		120 V AC, 60 HZ, 20 A		
Maximum Power Consumption		2 kW or less When in the Sleep Mode: 0.9 W Main Power Turned Off: Quick Startup Settings for Main Power is set to 'Off': Approximately 0.3 W Quick Startup Settings for Main Power is set to 'On': Approximately 0.45 W		
Dimensions (H x W x D) (With the Duplex Color Image Reader Unit-F1)		48 1/8" x 27 1/8" x 36 3/4" (1,221 mm x 689 mm x 932 mm)		
Weight (Including the Toner Bottle)		Approximately 604 lb (274 kg)		
Installation Space (W x D)		52 7/8" x 36 3/4" (1,344 mm x 932 mm) (When the Copy Tray-P1 and Duplex Color Image Reader Unit-F1 are attached, and the multi-purpose tray and auxiliary tray are extended.)		

6.2 Duplex Color Image Reader Unit-F1

Item	Specifications
Original Feeding Mechanism	Single Pass Duplex Automatic Document Feeder
Size and Weight of Originals	11" x 17", LGL, LTR, LTRR, STMT, or STMTR 1-Sided Scanning: 13 lb bond to 80 lb cover (50 to 220 g/m ²) 2-Sided Scanning: Black-and-White Original: 13 lb bond to 80 lb cover (50 to 220 g/m ²) Color Original: 17 lb bond to 80 lb cover (64 to 220 g/m ²)
Original Tray Capacity	300 sheets (20 lb bond (80 g/m ²))
Original Scanning Speed	Copying: LTR in Black-and-White at 600 dpi: 1-sided scanning: 120 sheets/minute ^{*1} 2-sided scanning: 60 sheets (120 pages)/minute ^{*1} LTR in Color at 600 dpi: 1-sided scanning: 70 sheets/minute 2-sided scanning: 35 sheets (70 pages)/minute Scanning: LTR in Black-and-White at 300 dpi: 1-sided scanning: 120 sheets/minute 2-sided scanning: 100 sheets (200 pages)/minute ^{**1} LTR in Color at 300 dpi: 1-sided scanning: 120 sheets/minute 2-sided scanning: 70 sheets (140 pages)/minute ^{*1} When 'Speed Priority' is selected. The scanning speed may vary, depending on the scanning mode and original type.
Resolution for Reading	Up to 600 dpi x 600 dpi
Number of Tones	256
Acceptable Originals	Sheet, book, three dimensional objects (up to 4.4 lb (2 kg))
Magnification	Regular paper size: Same Ratio Direct Reduction 1:0.78 (LGL → LTR) 1:0.73 (11" x 17" → LGL, 11" x 15" → LTR) 1:0.64 (11" x 17" → LTR) 1:0.50 (11" x 17" → STMT) 1:0.25 Enlargement 1:1.21 (LGL → 11" x 17") 1:1.29 (LTR → 11" x 17") 1:2.00 (STMT → 11" x 17") 1:4.00 Copy Ratio: 25 to 400% (in 1% increments)
Power Source	From the main unit.
Maximum Power Consumption	Approximately 185 W
Dimensions (H x W x D)	10" x 25" x 23 7/8" (253 mm x 635 mm x 605 mm)
Weight	Approximately 87.1 lb (39.5 kg)

6.3 Paper Deck Unit-C1

Item	Specifications
Paper Size/Weight/Type	<p>Size: LTR</p> <p>Weight: 14 lb bond to 80 lb cover (52 to 220 g/m²)</p> <p>Type:^{*1} Thin, Plain 1, Plain 2, Heavy 1, Heavy 2, Color, Recycled, and Pre-Punched</p> <p>^{*1} For detailed supported paper weights, see "Media Feed Locations." on p. 60.</p>
Paper Deck Capacity	3,500 sheets (20 lb bond (80 g/m ²))
Power Source	From the main unit.
Maximum Power Consumption	Approximately 44 W
Dimensions (H x W x D)	22 1/2" x 12 3/4" x 23" (570 mm x 323 mm x 583 mm)
Weight	Approximately 81.6 lb (37 kg)
Installation Space Including the Main Unit (W x D)	<p>Without the Upright Control Panel: 54 7/8" x 36 3/4" (1,393 mm x 932 mm)</p> <p>With the Upright Control Panel: 63" x 36 3/4" (1,600 mm x 932 mm)</p> <p>(When the Copy Tray-P1 is attached, and the auxiliary tray is extended.)</p>

6.4 POD Deck Lite-A1

Item	Specifications
Paper Size/Weight/Type	<p>Size: 13" x 19", 12 5/8" x 17 11/16", 12" x 18", 11" x 17", LGL, LTR, and LTRR</p> <p>Weight: 14 lb bond to 110 lb cover (52 to 300 g/m²)</p> <p>Type:^{*1} Thin, Plain 1, Plain 2, Heavy 1, Heavy 2, Heavy 3, Heavy 4, Color, Recycled, Pre-Punched, Bond, Labels, Transparency, Coated, Textured, and Letterhead</p> <p>^{*1} For detailed supported paper weights, see "Media Feed Locations." on p. 60.</p>
Paper Deck Capacity	3,500 sheets (20 lb bond (80 g/m ²))
Power Source	120-127 V AC, 60 Hz, 2,4 A
Maximum Power Consumption	Approximately 263 W
Dimensions (H x W x D)	22 1/2" x 23 5/8" x 24 1/2" (570 mm x 601 mm x 621 mm)
Weight	Approximately 110 lb (50 kg)
Installation Space Including the Main Unit (W x D)	<p>65 3/4" x 36 3/4" (1,671 mm x 932 mm)</p> <p>(When the Copy Tray-P1 is attached, and the auxiliary tray is extended.)</p>

6.5 Document Insertion Unit-J1

Item	Specifications
Paper Size/Weight/Type	<p>Size: 13" x 19", 12 5/8" x 17 11/16", 12" x 18", 11" x 17", LGL, LTR, LTRR, and EXEC</p> <p>Weight: 16 lb bond to 140 lb index (60 to 256 g/m²)</p> <p>Type:^{*1} Thin, Plain 1, Plain 2, Heavy 1, Heavy 2, Heavy 3, Color, Recycled, Tab, Bond, Letterhead, Coated, and Textured</p> <p>^{*1} For detailed supported paper weights, see "Media Feed Locations." on p. 60.</p>
Paper Capacity	100 sheets (20 lb bond (80 g/m ²))
Power Source	100-240 V AC, 50/60 Hz, 1.0 A
Maximum Power Consumption	Approximately 85 W
Dimensions (H x W x D)	48 7/8" x 26 1/8" x 26 3/4" (1,242 mm x 662 mm x 679 mm)
Weight	Approximately 88.2 lb (40 kg)
Installation Space Including the Main Unit (W x D)	82 3/4" x 36 3/4" (2,103 mm x 932 mm) (When the Buffer Pass Unit-J1 and optional Staple Finisher-L1 or Booklet Finisher-L1 are attached, and the multi-purpose tray and auxiliary tray are extended.)

6.6 Document Insertion/Folding Unit-G1

Item	Specifications
Paper Size/Weight/Type	<p>Size:</p> <p>Z-Fold: LTRR, LGL, 11" x 17"</p> <p>C-Fold: LTRR</p> <p>Insertion Unit: 13" x 19", 12 5/8" x 17 11/16", 12" x 18", 11" x 17", LGL, LTR, LTRR, and EXEC</p> <p>Weight:</p> <p>Z-Fold: 16 to 28 lb bond (60 to 105 g/m²)</p> <p>C-Fold: 16 to 28 lb bond (60 to 105 g/m²)</p> <p>Insertion Unit: 16 lb bond to 140 lb index (60 to 256 g/m²)</p> <p>Type:^{*1}</p> <p>Z-Fold/C-Fold: Thin, Plain 1, Plain 2, Color, and Recycled</p> <p>Insertion Unit: Thin, Plain 1, Plain 2, Heavy 1, Heavy 2, Heavy 3, Color, Recycled, Tab, Bond, Letterhead, Coated, and Textured</p> <p>^{*1} For detailed supported paper weights, see "Media Feed Locations." on p. 60.</p>
Capacity of the Exit Slot	C-Fold: 40 sheets (20 lb bond (80 g/m ²)) (or 2 3/8" (60 mm) in height)
Capacity of Document Insertion Unit	100 sheets (20 lb bond (80 g/m ²))
Power Source	100-240 V AC, 50/60 Hz, 1.0 A
Maximum Power Consumption	Approximately 136 W
Dimensions (H x W x D)	48 7/8" x 26 1/8" x 26 3/4" (1,242 mm x 662 mm x 679 mm)
Weight	Approximately 168 lb (76 kg)
Installation Space Including the Main Unit (W x D)	83 7/8" x 36 3/4" (2,130 mm x 932 mm) (When the Buffer Pass Unit-J1 and optional Staple Finisher-L1 or Booklet Finisher-L1 are attached, and the multi-purpose tray and auxiliary tray are extended.)

6.7 Copy Tray-P1

Item	Specifications
Paper Size/Weight/Type	<p>Size: 13" x 19", 12 5/8" x 17 11/16", 12" x 18", 11" x 17", LGL, LTR, LTRR, EXEC, STMTR, Custom Size (4" x 5 7/8" to 13" x 19 1/4" (100 mm x 148 mm to 330.2 mm x 487.7 mm)), and Envelopes</p> <p>Weight: 14 lb bond to 110 lb cover (52 to 300 g/m²)</p> <p>Type:^{*1} Thin, Plain 1, Plain 2, Heavy 1, Heavy 2, Heavy 3, Heavy 4, Color, Recycled, Pre-Punched, Transparency, Tracing, Labels, Tab, Bond, Letterhead, Coated, Textured, and Envelopes</p> <p>^{*1} For detailed supported paper weights, see "Media Feed Locations." on p. 60.</p>
Paper Capacity	<p>1-Sided: 250 sheets (20 lb bond (80 g/m²))</p> <p>2-Sided: 100 sheets (20 lb bond (80 g/m²))</p>
Dimensions (H x W x D)	6 7/8" x 16 1/2" x 15" (175 mm x 420 mm x 382 mm)
Weight	Approximately 2.9 lb (1.3 kg)
Installation Space Including the Main Unit (W x D)	52 7/8" x 36 3/4" (1,344 mm x 932 mm) (The auxiliary tray is extended.)

6.8 Staple Finisher-L1

Item	Specifications
Paper Size/Weight/Type	<p>Size: 13" x 19", 12 5/8" x 17 11/16", 12" x 18", 11" x 17", LGL, LTR, LTRR, EXEC, STMTR, Custom Size (4" x 5 7/8" to 13" x 19 1/4" (100 mm x 148 mm to 330.2 mm x 487.7 mm)), and Envelopes</p> <p>Weight:</p> <p>Tray A: 14 lb bond to 140 lb index (52 to 256 g/m²), Tray B/Tray C: 14 lb bond to 110 lb cover (52 to 300 g/m²)^{*1}</p> <p>Type:^{*1} Thin, Plain 1, Plain 2, Heavy 1, Heavy 2, Heavy 3, Heavy 4, Color, Recycled, Pre-Punched, Transparency, Tracing, Labels, Tab, Bond, Letterhead, Coated, Textured, and Envelopes</p> <p>^{*1} For detailed supported paper weights, see "Media Feed Locations." on p. 60.</p>

Staple Finisher-L1 Table Continued

Item	Specifications
Capacity Per Tray	<p>No Collating Mode</p>
	<p>Tray A: LTR, STMTR, EXEC: 250 sheets (or 1 3/4" (43 mm) in height) 13" x 19", 12 5/8" x 17 3/4", 12" x 18", 11" x 17", LGL, LTRR: 125 sheets (or 7/8" (21 mm) in height)</p>
	<p>Tray B: LTR, STMTR, EXEC: 1,300 sheets (or 7 3/8" (188 mm) in height)^{*1} 13" x 19", 12 5/8" x 17 3/4", 12" x 18", 11" x 17", LGL, LTRR: 650 sheets (or 3 3/4" (96 mm) in height)</p>
	<p>Tray C: LTR: 2,450 sheets (or 13 5/8" (347 mm) in height)^{*1} STMTR, EXEC: 1,700 sheets (or 9 5/8" (243 mm) in height)^{*1} 13" x 19", 12 5/8" x 17 3/4", 12" x 18", 11" x 17", LGL, LTRR: 650 sheets (or 3 3/4" (96 mm) in height)</p>
	<p>Collate and Group Modes</p>
	<p>Tray B: LTR, EXEC: 1,300 sheets (or 7 3/8" (188 mm) in height)^{*1} 11" x 17", LGL, LTRR: 650 sheets (or 3 3/4" (96 mm) in height)</p>
	<p>Tray C: LTR, EXEC: 1,700 sheets (or 9 5/8" (243 mm) in height)^{*1} 11" x 17", LGL, LTRR: 650 sheets (or 3 3/4" (96 mm) in height)</p>
	<p>Staple Mode</p>
	<p>Tray B and C: LTR, EXEC: 1,300 sheets/100 sets (or 7 3/8" (188 mm) in height)^{*1} 11" x 17", LGL, LTRR: 650 sheets/50 sets (or 3 3/4" (96 mm) in height)</p>
	<p>Z-Fold Mode (When the Document Insertion/Folding Unit-G1 Is Attached)</p>
	<p>Tray B, C: 11" x 17": Up to 30 sheets (10 sheets per set when stapling) LGL, LTRR: Up to 10 sheets</p>
	<p>No Collating, Collate, or Group Mode with Different paper Sizes</p>
<p>Tray B, C: 650 sheets (or 3 3/4" (96 mm) in height)</p>	
<p>Staple Mode with Different Paper Sizes</p>	
<p>Tray B, C: 650 sheets/50 sets (or 3 3/4" (96 mm) in height)</p>	
<p>^{*1} Up to 650 sheets (or 3 3/4" (96 mm) in height) when thin paper or custom paper (lighter than 16 lb bond (59 g/m²)) is selected.</p>	

Staple Finisher-L1 Table Continued

Item	Specifications
Max. Stapling Capacity/Available Staple Size	When the Standard Staple Cartridge Is Attached: (The maximum stapling capacity may vary, depending on the paper type and weight.) LTR, EXEC: 50 sheets (20 lb bond (80 g/m ²)) 11" x 17", LGL, LTRR: 30 sheets (20 lb bond (80 g/m ²)) Corner Staple and Double Staple Sizes: 11" x 17", LGL, LTR, LTRR, EXEC
Power Source	From the main unit.
Maximum Power Consumption	Approximately 130 W (Including the External 2/3 Hole Puncher-A1) Approximately 124 W (Including the External 2/3 Hole Puncher-A1)
Dimensions (H x W x D)	44 1/8" x 25 3/8" (30") ^{*1} x 25 7/8" (1,121 mm x 644 mm (761 mm) ^{*1} x 656 mm) *1 When the auxiliary tray is extended.
Weight	Approximately 106 lb (48 kg)
Installation Space Including the Main Unit (W x D)	73 5/8" x 36 3/4" (1,870 mm x 932 mm) (When the Buffer Pass Unit-J1 is attached, and the multi-purpose tray and auxiliary tray are extended.) 78" x 36 3/4" (1,982 mm x 932 mm) (When the Buffer Pass Unit-J1 and optional External 2/3 Hole Puncher-A1 are attached, and the auxiliary tray is extended.)

6.9 Booklet Finisher-L1

Item	Specifications
<p>Paper Size/Weight/Type</p>	<p>Size: 13" x 19", 12 5/8" x 17 11/16", 12" x 18", 11" x 17", LGL, LTR, LTRR, EXEC, STMTR, Custom Size (4" x 5 7/8" to 13" x 19 1/4" (100 mm x 148 mm to 330.2 mm x 487.7 mm)), and Envelopes</p> <p>Weight:</p> <p>Tray A: 14 lb bond to 140 lb index (52 to 256 g/m²) Tray B/Tray C: 14 lb bond to 110 lb cover (52 to 300 g/m²)*¹</p> <p>Type:^{*1} Thin, Plain 1, Plain 2, Heavy 1, Heavy 2, Heavy 3, Heavy 4, Color, Recycled, Pre-Punched, Transparency, Tracing, Labels, Tab, Bond, Letterhead, Coated, Textured, and Envelopes</p> <p>*¹ For detailed supported paper weights, see "Media Feed Locations." on p. 60.</p>

Booklet Finisher-L1 Table Continued

Item	Specifications
Capacity Per Tray	<p>No Collating Mode</p> <p>Tray A: LTR, STMTR, EXEC: 250 sheets (or 1 3/4" (43 mm) in height) 13" x 19", 12 5/8" x 17 3/4", 12" x 18", 11" x 17", LGL, LTRR: 125 sheets (or 7/8" (21 mm) in height)</p> <p>Tray B: LTR, STMTR, EXEC: 1,300 sheets (or 7 3/8" (188 mm) in height)^{*1} 13" x 19", 12 5/8" x 17 3/4", 12" x 18", 11" x 17", LGL, LTRR: 650 sheets (or 3 3/4" (96 mm) in height)</p> <p>Tray C: LTR: 2,450 sheets (or 13 5/8" (347 mm) in height)^{*1} STMTR, EXEC: 1,700 sheets (or 9 5/8" (243 mm) in height)^{*1} 13" x 19", 12 5/8" x 17 3/4", 12" x 18", 11" x 17", LGL, LTRR: 650 sheets (or 3 3/4" (96 mm) in height)</p> <p>Collate and Group Modes</p> <p>Tray B: LTR, EXEC: 1,300 sheets (or 7 3/8" (188 mm) in height)^{*1} 11" x 17", LGL, LTRR: 650 sheets (or 3 3/4" (96 mm) in height)</p> <p>Tray C: LTR, EXEC: 1,700 sheets (or 9 5/8" (243 mm) in height)^{*1} 11" x 17", LGL, LTRR: 650 sheets (or 3 3/4" (96 mm) in height)</p> <p>Staple Mode</p> <p>Tray B and C: LTR, EXEC: 1,300 sheets/100 sets (or 7 3/8" (188 mm) in height)^{*1} 11" x 17", LGL, LTRR: 650 sheets/50 sets (or 3 3/4" (96 mm) in height)</p> <p>Z-Fold Mode (When the Document Insertion/Folding Unit-G1 Is Attached)</p> <p>Tray B, C: 11" x 17": Up to 30 sheets (10 sheets per set when stapling) LGL, LTRR: Up to 10 sheets</p> <p>No Collating, Collate, or Group Mode with Different paper Sizes</p> <p>Tray B, C: 650 sheets (or 3 3/4" (96 mm) in height)</p> <p>Staple Mode with Different Paper Sizes</p> <p>Tray B, C: 650 sheets/50 sets (or 3 3/4" (96 mm) in height)</p> <p>Saddle Stitch Mode</p> <p>1 to 5 sheets/25 sets, 6 to 10 sheets/15 sets, 11 to 16 sheets/10 sets</p> <p>^{*1} Up to 650 sheets (or 3 3/4" (96 mm) in height) when thin paper or custom paper (lighter than 16 lb bond (59 g/m²)) is selected.</p>

Booklet Finisher-L1 Table Continued

Item	Specifications
Max. Stapling Capacity/ Available Staple Size	<p>When the Standard Staple Cartridge Is Attached: (The maximum stapling capacity may vary, depending on the paper type and weight.)</p> <p>LTR, EXEC: 50 sheets (20 lb bond (80 g/m²)) 11" x 17", LGL, LTRR: 30 sheets (20 lb bond (80 g/m²))</p> <p>Corner Staple and Double Staple Sizes: 11" x 17", LGL, LTR, LTRR, EXEC</p>
Available Saddle Stitch Capacity/Size	<p>Saddle Stitch:</p> <p>16 sheets (including 1 cover sheet (140 lb index (256 g/m²)) (20 lb bond (80 g/m²))</p> <p>Saddle Folding:</p> <p>1 sheet (16 lb bond to 140 lb index (60 to 256 g/m²)) (20 lb bond (80 g/m²))</p> <p>Size: 12" x 18", 11" x 17", LGL, LTRR</p>
Power Source	From the main unit
Maximum Power Consumption	<p>Approximately 151 W (Including the External 2/3 Hole Puncher-A1)</p> <p>Approximately 125 W (Including the External 2/3 Hole Puncher-A1)</p>
Dimensions (H x W x D)	<p>44 1/8" x 25 1/2" (30")^{*1} x 25 7/8" (1,121 mm x 646 mm (761 mm)^{*1} x 656 mm)</p> <p>*1 When the auxiliary tray is extended.</p>
Weight	Approximately 158.7 lb (72 kg)
Installation Space Including the Main Unit (W x D)	<p>73 5/8" x 36 3/4" (1,870 mm x 932 mm) (When the Buffer Pass Unit-J1 is attached, and the multi-purpose tray and auxiliary tray are extended.)</p> <p>78 1/4" x 36 3/4" (1,987 mm x 932 mm) (When the Buffer Pass Unit-J1 and optional External 2/3 Hole Puncher-A1 are attached, and the auxiliary tray is extended.)</p>

6.10 External 2/3 Hole Puncher-A1

Item	Specifications
Paper Size/Weight/Type	Size: 11" x 17", LGL, LTR, LTRR Weight: 14 lb bond to 140 lb index (52 to 256 g/m ²) Type: ^{*1} Thin, Plain 1, Plain 2, Heavy 1, Heavy 2, Heavy 3, Color, Recycled, Tab, Bond, Letterhead, Coated, and Textured *1 For detailed supported paper weights, see " Media Feed Locations ," on p. 60.
Punch Hole Quantity, Hole Diameter	Two holes: 1/4" (6.5 mm) Three holes: 3/8" (8 mm)
Distance between Punch Holes	Two holes: 2 3/4" (70 mm) Three holes: 4 1/4" (108 mm)
Paper Size in Which Holes Can be Punched	Two holes: LGL and LTRR Three holes: 11" x 17" and LTR
Punch Waste Tray Capacity	When approximately 10,000 sheets of paper (20 lb bond (80 g/m ²)) have been punched.
Power Source	From the main unit.
Dimensions (H x W x D)	32 1/2" x 4 1/4" x 24 1/4" (825 mm x 107 mm x 615 mm)
Weight	Approximately 17 lb (7.7 kg)
Installation Space Including the Main Unit (W x D)	78 1/4" x 36 3/4" (1,987 mm x 932 mm) (When the Buffer Pass Unit-J1 and optional Staple Finisher-L1 are attached, and the auxiliary tray is extended.)

6.11 Copy Card Reader-F1

Item	Specifications
Available Cards	Magnetic
Card Readout Method	Magnetic readout
Magnetic Card Reading Direction	Face up
Store/Replay	Replay
Power Source	From the main unit.
Dimensions (H x W x D)	1 5/8" x 3 1/2" x 3 3/4" (40 mm x 88 mm x 96 mm)
Weight	Approximately 7.1 oz (200 g) (Including the attachment kit and cable.)

6.12 Super G3 FAX Board-AD2

Protocol	Specifications ^{*1}
Telephone Line Used ^{*2}	Public Switched Telephone Network
Scan Line Density (Scan, Transmission)	Standard: 8 pels ^{*3} /mm x 3.85 line/mm Fine: 8 pels ^{*3} /mm x 7.7 line/mm Super-Fine: 8 pels ^{*3} /mm x 15.4 line/mm Ultra-Fine: 16 pels ^{*3} /mm x 15.4 line/mm
Transmission Speed	Super G3: 33.6 kbps G3: 14.4 kbps
Compression Method	MH, MR, MMR, JBIG
Transmission Type	Super G3, G3
Sending Original Size	11" x 17" to STMTR
Receiving Paper Size	11" x 17" to STMTR
Transmission Times	ECM-MMR: Approximately 3.2 seconds G3MR Method: Approximately 13 seconds G3MH Method: Approximately 13 seconds JBIG: Approximately 2.6 seconds
Auto Dial Function	Address Book: 1,800 destinations (Including destinations stored in one-touch buttons.)
Image Memory	Approximately 6,000 pages

*1 The specifications remain the same even when the optional Super G3 2nd Line Fax Board-AD1 or Super G3 3rd/4th Line Fax Board-AE1 is installed.

*2 If an IP telephone service is used, facsimile communications may not be performed normally via an IP telephone line. It is recommended to use a general telephone (Public Switched Telephone Network) line for facsimile communications.

*3 Pels stands for picture elements (pixels).

6.13 Protocol Specifications

Protocol	Specifications
TCP/IP	Frame Type: Ethernet II Print Applications: LPD, Raw, IPP, IPPS, FTP, WSD
IPX/SPX	Frame Type: Ethernet II, Ethernet 802.2, Ethernet 802.3, Ethernet SNAP, and Auto Detect Print Applications: Bindery PServer, NDS PServer, RPrinter, and NPrinter
AppleTalk	Frame Type: Ethernet SNAP Print Applications: PAP (Printer Access Protocol)

7. System Options

The functionality of the imageRUNNER ADVANCE C7260 can be expanded by installing system related optional accessories. This section describes the system related optional accessories and their functions.

7.1 PCL Printer Kit-AS1

The PCL Printer Kit-AS1 supports PCL5e/6 emulation printing solutions, and enables true 1,200 x 1,200 dpi print resolution with the PCL 6 driver.

7.2 PS Printer Kit-AS1

The PS Printer Kit-AS1 provides the ability to use the machine as a PS (PostScript) printer, and print in true 1,200 x 1,200 dpi resolution.



NOTE

To use the functions of the PS Printer Kit-AS1, the optional Additional Memory Type D (512 MB) must be installed on the machine to expand the machine's memory.

7.3 imagePASS-A2

The imagePASS-A2 Printer Kit is a printer controller that attaches to the back of the machine. The imagePASS print controller supports Adobe Genuine PostScript 3, PCL5c, and PCL6, and is suited for office environments in which larger print volumes are frequently processed, or for users who use Adobe PostScript or other PostScript applications.

The table below represents the hardware specifications for the imagePASS-A2 print controller.

Item	Specifications
Base OS	Linux
CPU	Intel Pentium Dual Core E5300 2.6 GHz
RAM	2 GB (1 GB x 2 DDR3 – 1,333 MHz)
HDD	160 GB SATA, 3.5 inch
H/W Platform	E100
F/W	Fiery System 10e
PostScript 3	Y
PCL6	Y
PCL5c	Y
Print Drivers	<ul style="list-style-type: none">• Windows 2000/XP/Server 2003/Server 2008/Windows Vista/Windows 7/Windows 8• Macintosh OS X 10.5, 10.6, and 10.7 (Intel only)• (Macintosh OS X 10.4 and earlier not supported)
Optional Items	<ul style="list-style-type: none">• SecureErase V1.1• SeeQuence Suite (Impose & Compose)• SeeQuence Impose• SeeQuence Compose
Dimensions (H x W x D)	11.7" x 13.2" x 3.7" (296 mm x 336 mm x 93 mm)
Weight	Approximately 11.9 lb (5.4 kg)

NOTE

- To use the functions of the imagePASS-A2 print controller, the optional Additional Memory Type D (512 MB) must be installed on the machine to expand the machine's memory.
- UFR II (Ultra Fast Rendering II) is not supported.

7.4 ColorPASS-GX400

The ColorPASS-GX400 is an external print controller that delivers power, performance, and speed to high-end print environments. This controller offers extensive, variable data printing support and superior workflow management. The ColorPASS-GX400 produces true 1,200 x 1,200 dpi print quality, and features the PostScript 3 print language. It also comes packaged with the Command Workstation 5.0 software. The Command Workstation makes managing demanding workflows easier by centralizing job management.

The table below represents the hardware specifications for the ColorPASS-GX400 print controller.

Item	ColorPASS-GX400
Base OS	Windows 7 Professional FES (64 bit)
CPU	Intel Core i5-660 3.33 GHz up to 3.6 GHz w/Turbo
RAM	GB (1 GB x 2) DDR3, 1,333 MHz
HDD	500 GB SATA, 3.5 inch
H/W Platform	PRO80
F/W	Fiery System 10
PostScript 3	Y
PCL6	N
PCL5	N
Print Drivers	<ul style="list-style-type: none"> • Windows 2000/XP/Server 2003/Server 2008/Windows Vista/Windows 7/Windows 8 • Macintosh OS X 10.5, 10.6, and 10.7 (Intel only) • (Macintosh OS X 10.4 and earlier not supported)
Optional Items	<ul style="list-style-type: none"> • Integrated Interface & Stand-A1 • X-Rite Eye-One • SeeQuence Suite (Impose & Compose) • SeeQuence Impose • SeeQuence Compose • Graphic Arts Feature Set Premium Edition V2.3 • Removable HDD Kit-B1
Dimensions (H x W x D)	19 1/8" x 8 1/2" x 19 1/8" (485 mm x 215 mm x 483 mm)
Weight	Approximately 43.4 lb (19.7 kg)



NOTE

- To use the functions of the ColorPASS-GX400, the optional Additional Memory Type D (512 MB) must be installed on the machine to expand the machine's memory.
- UFR II (Ultra Fast Rendering II) is not supported.

7.5 Direct Print Kit (for PDF/XPS Files)-H1

The Direct Print Kit (for PDF/XPS)-H1 enables the user to print PDF and XPS files directly from the Remote UI. It also enables the user to print PDF files from Memory Media.



NOTE

To use the functions of the Direct Print Kit (for PDF/XPS)-H1, the optional Additional Memory Type D (512 MB) must be installed on the machine to expand the machine's memory.

7.6 Additional Memory Type D (512 MB)

The Additional Memory Type D (512 MB) expands the memory capacity of the machine to 2.5 GB. It is necessary that the Additional Memory Type D be installed to enable the functions of the optional PS Printer Kit-AS1, Direct Print Kit (for PDF/XPS), imagePASS-A2, and ColorPASS-GX400.

7.7 Super G3 FAX Board-AD2

The Super G3 FAX Board-AD2 enables the user to send and receive fax documents. The user can also send documents that have been created in applications directly from their computer via a network.



NOTE

The Canon Fax Driver is supplied with the Super G3 FAX Board-AD2. It enables the user to send fax images from a computer via the machine.

7.8 Super G3 2nd Line Fax Board-AD1

The Super G3 2nd Line Fax Board-AD1 provides two lines to send and receive fax documents.



NOTE

The Super G3 FAX Board-AD2 is required.

7.9 Super G3 3rd/4th Line Fax Board-AE1

The Super G3 3rd/4th Line Fax Board-AE1 provides three or four lines to send and receive fax documents.



NOTE

The Super G3 FAX Board-AD2 and Super G3 2nd Line Fax Board-AD1 are required.

7.10 Remote FAX Kit-A1

The Remote FAX Kit-A1 enables the user to share the Fax function on an imageRUNNER ADVANCE machine (with the Remote FAX Kit-A1) with another imageRUNNER ADVANCE machine (that has a fax board installed) on the same network. Fax documents can be sent and received via the imageRUNNER ADVANCE machine with a fax board from an imageRUNNER ADVANCE machine that has the Remote FAX Kit-A1.

NOTE

- To enable the functions of the Remote FAX Kit-A1, it must be activated by registering a license key.
- The Remote FAX Kit-A1 and Super G3 FAX Board-AD2 cannot be installed at the same time.

7.11 Universal Send Advanced Feature Set-F1

The Universal Send Advanced Feature Set-F1 enables the user to make Trace & Smooth PDF, Searchable PDF/XPS, Adobe Reader Extensions PDF, and Office Open XML files.

NOTE

- For more information on the Universal Send Advanced Feature Set-F1 modes, see the *Optional Products e-Manual*.
- To enable the functions of the Universal Send Advanced Feature Set-F1, it must be activated by registering a license key.

7.12 Universal Send Security Feature Set-D1

The Universal Send Security Feature Set-D1 enables the user to encrypt PDF and Digital Device Signature PDF/XPS files, as well as set a password to send them safely to a file server or e-mail address. It also enables the recipient of a PDF or Digital Device Signature PDF/XPS file to verify which device scanned it.

NOTE

To enable the functions of the Universal Send Security Feature Set-D1, it must be activated by registering a license key.

7.13 Universal Send Digital User Signature Kit-C1

The Universal Send Digital User Signature Kit-C1 enables the user to add a digital user signature obtained from a certificate authority to a PDF or XPS file. This enables the recipient of a PDF or XPS file to verify which user signed it.

NOTE

A license key issued by a certificate authority must be registered to activate the Universal Send Digital User Signature Kit-C1.

7.14 Secure Watermark-B1

The Secure Watermark-B1 option enables the user to embed hidden text in the background of copies. The embedded text only appears when the machine prints the copies.

NOTE

- To enable the Secure Watermark-B1 option, it must be activated by registering a license key.
- The Secure Watermark-B1 option cannot be used with the optional Document Scan Lock Kit-B1.

7.15 Document Scan Lock Kit-B1

The Document Scan Lock Kit-B1 enables the user to embed hidden user information or copy restriction information in the output when documents are copied or printed. This helps to reduce the risk of confidential information from being leaked. The Document Scan Lock Kit-B1 also enforces the policies written to track information embedded in the document to prevent users from performing restricted tasks, such as copying, sending, scanning, or storing specific documents (Scan Lock function) and identifies the user that output the document (Tracking function).

The Image Data Analyzer Board, which is needed to detect the scan lock information, restrict unauthorized copying, and analyze the tracking information is included with this kit.

NOTE

- To enable the functions of the Document Scan Lock Kit-B1, it must be activated by registering a license key.
- The Document Scan Lock Kit-B1 cannot be used with the optional Secure Watermark-B1.

7.16 HDD Data Encryption & Mirroring Kit-C7

The HDD Data Encryption & Mirroring Kit-C7 encrypts all image data and device settings before storing it on the hard drive. The mirroring function also provides redundancy when utilized with an additional hard disk drive of the same storage capacity. This maintains system uptime and preserves company data in the instance of a hard drive failure.



IMPORTANT

Installing the HDD Data Encryption & Mirroring Kit-C7 (after the machine is installed and operational), requires the machine's system software to be updated. This reformats the entire hard drive, and all data previously stored on the hard disk drive is deleted. Accordingly, it is strongly recommended that all of the data stored on the hard disk drive of the machine is backed up prior to installing the HDD Data Encryption & Mirroring Kit-C7.



NOTE

- The engine HDD and the HDD used for mirroring must be of the same storage capacity.
- The optional 2.5inch/160 GB HDD-G1 is required for the mirroring capability.
- The encryption capability is Common Criteria Certified.

7.17 Encrypted Secure Print Software-D1

The Encrypted Secure Print Software-D1 enables the user to encrypt print data sent from a computer using the Secured Print function and decrypt it at the machine. This strengthens the security of print data by preventing the content of printed documents from being seen by other users, and preventing the unauthorized use of confidential information.



NOTE

To use the Encrypted Secure Print Software-D1, it must be activated by registering a license key.

7.18 Removable HDD Kit-AH1

The Removable HDD Kit-AH1 enables the hard disk of the machine to be removed while the machine is unattended or not in use. This kit provides a layer a data security for government agencies and corporate enterprises who need to ensure that the data stored on the hard disk is physically secured when the machine is no longer in use. The kit includes a carrying case and a key to enable easy removal and storage.

7.19 2.5inch/160 GB HDD-G1

Attach the optional 2.5inch/160 GB HDD-G1 to the machine to enable HDD Mirroring.

NOTE

- The 2.5inch/160 GB HDD-G1 is necessary if a user wants to perform HDD Mirroring with the HDD Mirroring Kit or HDD Data Encryption & Mirroring Kit-C7.
- The 2.5inch/160 GB HDD-G1 does not increase the overall storage capacity of the machine.

7.20 2.5inch/1 TB HDD-L1

Replace the machine's standard 160 GB hard disk drive with the 2.5inch/1 TB HDD-L1 to increase the HDD capacity to 1 TB.

NOTE

If the machine is configured with the optional HDD Data Encryption & Mirroring Kit-C7 and the optional 2.5inch/1 TB HDD-L1, an additional optional 2.5inch/1 TB HDD-L1 is required to enable the mirroring capability of the primary drive.

7.21 Remote Operator's Software Kit-B1

The Remote Operator's Software Kit-B1 enables the user to access machine's control panel and specify settings or process jobs from a computer (located on the same network as the machine) remotely.

7.22 USB Device Port-A2

The USB Device Port-A2 adds two USB ports to the machine so a third-party card reader or the optional Multimedia Reader/Writer-A2 can be used for additional media support.

7.23 Multimedia Reader/Writer-A2

The Multimedia Reader/Writer-A2 enables the user to use SD, Compact Flash, Memory Stick, and Microdrive memory media for direct print and scan to store operations.

NOTE

To use the Multimedia Reader/Writer-A2, the optional USB Device Port-A2 must be installed.

7.24 Silex Wireless Bridge SX-2500CG

The Silex Wireless Bridge SX-2500CG enables the machine to connect to a wireless network environment. It enables 10/100BASE-TX wired device operation in 802.11b/g wireless LAN networks.

7.25 Web Access Software-H1

The Web Access Software-H1 enables the user to view Web pages from the touch panel display of the machine. If PDF files are registered on the Web page, the user can print them from the machine without using a computer. Moreover, if a Web page or special content is created, and then registered as a PDF file, the Web page or special content can be shared with other users.



NOTE

To print PDF files from Web pages, the optional PS Printer Kit-AS1 or Direct Print Kit (for PDF/XPS)-H1, and the Additional Memory Type D (512 MB) must be installed.

7.26 Other imageRUNNER ADVANCE C7260 Main Unit Accessory Options

- Voice Guidance Kit-F2
- Voice Operation Kit-C2
- ADF Access Handle-A1
- Braille Label Kit-F1
- Barcode Printing Kit-D1
- Copy Control Interface Kit-A1 (Print-for-Pay solution)
- Serial Interface Kit-K1 (Print-for-Pay solution)

8. Installation Review

This chapter describes the necessary number of technicians required to install the machine properly, the time required to install the main unit and optional equipment, and customer installation responsibilities.

8.1 Installation Time

The time required to install the imageRUNNER ADVANCE C7260 depends on the options and accessories to be installed, and the number of technicians performing the installation. Customers should discuss the time requirements with their servicing dealer and schedule the installation accordingly.

The table below indicates the estimated length of time needed to install the main unit and optional accessories from the time the machine is unpacked to when it is installed, and calculated from the average amount of manpower hours. The estimated installation times are based on up to four (4) experienced technicians.

Description	Estimated Time
imageRUNNER ADVANCE C7260 – Main Unit and Buffer Pass Unit	45 minutes
Duplex Color Image Reader Unit-F1	10 minutes
Upright Control Panel-A1	27.7 minutes
Paper Deck Unit-C1	14.3 minutes
POD Deck Lite-A1	17 minutes
Staple Finisher-L1	9.7 minutes
Booklet Finisher-L1	10 minutes
External 2/3 Hole Puncher-A1	10.3 minutes
Copy Card Reader-F1	12 minutes
Copy Card Reader-F1 with the Upright Control Panel-A1	8.6 minutes
Copy Tray-P1	2.3 minutes
Document Insertion Unit-J1	15 minutes
Document Insertion/Folding Unit-G1	14.7 minutes
Multimedia Reader/Writer-A2	13 minutes
USB Device Port-A2	7.2 minutes
Super G3 FAX Board-AD2	10 minutes
Super G3 2nd Line Fax Board-AD1	18.1 minutes
Super G3 2nd Line Fax Board-AD1 & Super G3 3rd/4th Line Fax Board-AE1	28.6 minutes
Additional Memory Type D (512 MB)	4 minutes
Voice Guidance Kit-F2	10.6 minutes
Voice Operation Kit-C2	10.6 minutes
Removable HDD Kit-AB1	25 minutes
HDD Data Encryption & Mirroring Kit-C7	25 minutes
2.5inch/160 GB HDD-G1	9.2 minutes
2.5inch/1 TB HDD-L1	9.2 minutes
Document Scan Lock Kit-B1 (Image Data Analyzer Board)	8.1 minutes
imagePASS-A2	13.8 minutes
ColorPASS-GX400	22.1 minutes

8.2 Customer Installation Responsibilities

Item	Comment
Identify location for equipment.	Area meets space and service space requirements.
Verify strength of floor and level.	Certified by structural engineers.
Ensure that the equipment can be delivered to the site.	Path is clear and unobstructed.
Confirm proper electrical outlets and power are available.	Dedicated power, and enough outlets for equipment (including accessories).
Area meets environmental specifications.	Temperature and humidity are within specifications, venting provided if necessary.
Network connections available.	If desired.
Security systems and back up plan for data and storage available.	Highly recommended.
TPM key back up plan.	Must have a TPM key back up plan when the TPM setting is activated.



NOTE

For more information on backing up data, see “Backing Up/Exporting Data,” in the *Before Using This Machine* guide.

9. Consumable Items

Consumable items are all products and materials that are consumed with regular use and cannot be reused. Such consumables are included but not limited to paper, chemicals, and toner.

A number of factors go into the approximate life expectancy of a consumable item, including paper size and the amount of coverage per page.

The Usage Conditions and Consumables tables below state the estimated life expectancy yields based on LTR size paper. Using paper larger than LTR reduces the supply yields and parts life accordingly.

9.1 Usage Conditions

Operate the machine within the following usage conditions to achieve optimal machine performance.

Item	Condition
Operating Temperature	68°F to 80.6°F (20°C to 27°C)
Operating Humidity	30% to 70%
Optimal Performance Range	30,000 to 70,000 ^{*1}
Image Ratio	5%

*1 Based on 20 lb LTR size paper, and under the above optimal environmental conditions.

9.2 Consumable Parts

Consumable parts are defined as those parts having a limited life that will be reached during a customer's specific machine operation, and then should be replaced as needed. Examples of consumable parts include, but are not limited to feed rollers, cleaning blades, fixing assembly components, etc.

An estimated consumable parts life is provided below to assist in the initial parts/supplies planning. A consumable part's life expectancy is directly related to usage factors, such as paper size, paper quality, environment, usage application, and machine maintenance. Therefore, consumable parts do not have a warranty, and Canon U.S.A., Inc. cannot guarantee a minimum life.



NOTE

All consumable parts shown in the table below are for reference purposes only, and are subject to change without notice.

9.2.1 Estimated Life of Consumables

Item	Part Number	Quantity	Estimated Life ^{*1} (Copies/Prints)	Remarks
GPR-33 Black Toner	2792B003AA	1	80,000	5% image ratio
GPR-33 Cyan Toner	2796B003AA	1	52,000	
GPR-33 Magenta Toner	2800B003AA	1	52,000	
GPR-33 Yellow Toner	2804B003AA	1	52,000	

*1 Estimated life is based on LTR paper, single-sided print, and full color.

10. Toner Bottle Yields

The black toner bottle holds approximately 3.7 lb (1,660 g) of toner, and yields approximately 80,000 impressions at 5% coverage on LTR size paper.

The color toner bottles hold approximately 2.07 lb (940 g) of toner, and yield approximately 52,000 impressions at 5% coverage on LTR size paper.

11. Waste Toner Yields

The imageRUNNER ADVANCE C7260 uses a replaceable waste toner container, which collects the waste toner during the printing process.

The operator or service technician should replace the waste toner container when approximately 50,000 sheets of LTR paper at 100% color ratio and 5% image ratio have been printed. However, the capability for the operator to replace the waste toner container must be enabled by the service technician. Otherwise, only the service technician can perform this task. When the message is displayed that the waste toner container is full, up to an additional 1,000 sheets of LTR paper at 100% color ratio and 5% image ratio can be printed before the waste toner container must be replaced.

When the waste toner container becomes completely full, the imageRUNNER ADVANCE C7260 stops. The service technician (or operator, if enabled) must replace the full waste toner container with an empty waste toner container. Disposal of the full waste toner container must be done in a manner that is applicable to the laws in the geographical area where the machine is located. It is recommended that the customer maintain a supply of waste toner containers for replacement when necessary.

12. Optimum Monthly Product Performance

The table below describes the differences between the optimum PCV (Print Copy Volume), average PCV, maximum PCV, and duty cycle. Please note that the numbers in the table are for reference purposes only, and depend strongly on the type of media selected and environmental conditions. For information on the optimal environmental conditions for the machine, see [“Environmental Factors and Requirements,”](#) on p. 26.

Monthly PCV Type	Description	Number of Prints/Copies
Optimum PCV	This is the print/copy volume range that the equipment was intended to run on a regular basis to maintain a high level of performance and print/copy quality. Running the equipment within this range ensures that no undue stress is placed on components, and it allows time for the proper servicing and maintenance of the equipment.	30,000 to 70,000
Maximum PCV	This is the maximum number of prints/copies the machine can produce within a one-month period. However, sustained use of the machine at this print/copy level will impact the long term performance and durability of the machine. It is recommended to stay within the optimum print/copy volume, and reduce a possible increase in servicing and maintenance issues.	70,000
Duty Cycle	On occasion, the machine can produce up to 230,000 prints/copies. However, sustained use of the machine at this level, will significantly impact the long term performance and durability of the machine. The user should expect an increase in the number of service calls and down time during periods of maximum production use.	230,000



IMPORTANT

If the user's business constantly runs the machine at the duty cycle or is consistently run above the maximum PCV, the user should consider purchasing additional machines or higher volume machines.

13. Machine Productivity

This chapter describes the productivity of the imageRUNNER ADVANCE C7260.

13.1 Print Speed

One of the key features of the imageRUNNER ADVANCE C7260 is its print speed technology. The imageRUNNER ADVANCE C7260 prints a color, letter-sized sheet of bond paper weighing 14 lb bond (52 g/m²) at 55 ipm, and prints a black-and-white, letter-sized sheet of bond paper weighing 14 lb bond (52 g/m²) at 60 ipm.

There is an impact on print speed if the user is printing on paper of different sizes, weights, media, and if the user is printing double sided jobs. For more information, see [“Mixed Paper Weight Job Productivity,”](#) on p. 57.

The tables below describe the printing speeds one should expect when printing one- or two-sided documents on the indicated paper size and type.

Print Speed Table (1 of 2)

Paper Type	Mode	Size	Productivity (ipm)					
			Paper Drawers		Multi-Purpose Tray		Paper Deck	
			B&W	Color	B&W	Color	B&W	Color
Plain 1, Plain 2, Recycled 1, Recycled 2, Thin, Color, Tracing Paper, ^{*1} Pre-Punched (14 to 28 lb bond (52 to 105 g/m ²))	1-Sided	LTR/STMTR	60	55	36	60	55	
		LTRR	45	41	28	45	41	
		LGL	35	32	22	35	32	
		11" x 17"	30	27	18	30	27	
		12" x 18"	21 (28) ^{*2}	19 (26) ^{*2}	17	21 (28) ^{*2}	19 (26) ^{*2}	
	13" x 19"	17 (26) ^{*2}	16 (24) ^{*2}	16	17 (26) ^{*2}	16 (24) ^{*2}		
	2-Sided	LTR/STMTR	60	55	31	60	55	
		LTRR	45	41	24	45	41	
		LGL	35	32	19	35	32	
		11" x 17"	30	27	15	30	27	
12" x 18"		21 (28) ^{*2}	19 (26) ^{*2}	14	21 (28) ^{*2}	19 (26) ^{*2}		
13" x 19"	17 (26) ^{*2}	16 (24) ^{*2}	14	17 (26) ^{*2}	16 (24) ^{*2}			
Heavy 1, Heavy 2, Textured 1, ^{*3} Textured 2, ^{*3} Tab 1, ^{*4} Tab 2, ^{*4} (29 lb bond to 80 lb cover (106 to 220 g/m ²))	1-Sided	LTR/STMTR	30	27	18	30	27	
		LTRR	22	20	14	22	20	
		LGL	17	16	11	17	16	
		11" x 17"	15	13	9	15	13	
		12" x 18"	14	13	8	14	13	
	13" x 19"	13	12	8	13	12		
	2-Sided	LTR/STMTR	30	27	15	30	27	
		LTRR	22	20	12	22	20	
		LGL	17	16	9	17	16	
		11" x 17"	15	13	7	15	13	
12" x 18"		14	13	7	14	13		
13" x 19"	13	12	7	13	12			

*1 Tracing paper can only be loaded in the Multi-Purpose Tray.

*2 The numbers in parentheses also refer to paper types (except for Thin) in which 5 minutes have passed after they are fed from their respective paper sources.

*3 Textured 1 and Textured 2 can only be loaded in the POD Deck Lite-A1, Multi-Drawer Paper Deck-A1, and Multi-Purpose Tray one sheet at a time.

*4 Tab 1 and Tab 2 can only be loaded in the paper drawers.

Print Speed Table Continued (2 of 2)

Paper Type	Mode	Size	Productivity (ipm)					
			Paper Drawers		Multi-Purpose Tray		Paper Deck	
			B&W	Color	B&W	Color	B&W	Color
Heavy 3, ^{*5} Heavy 4, ^{*5} Textured 3, ^{*6} Textured 4, ^{*6} (82 lb cover to 110 lb cover (221 to 300 g/m ²))	1-Sided	LTR/STMTR	20	18	12	20	18	
		LTRR	15	13	9	15	13	
		LGL	11	10	7	11	10	
		11" x 17"	10	9	6	10	9	
		12" x 18"	9	8	5	9	8	
	13" x 19"	8	8	5	8	8		
	2-Sided	LTR/STMTR	-	-	-	-	-	
		LTRR	-	-	-	-	-	
		LGL	-	-	-	-	-	
		11" x 17"	-	-	-	-	-	
12" x 18"		-	-	-	-	-		
13" x 19"	-	-	-	-	-			
Coated 1, ^{*7} Coated 2, ^{*7} Coated 3, ^{*7} Coated 4, ^{*7} for 1-sided/2-sided (29 lb bond to 110 lb cover (106 to 300 g/m ²))	1-Sided (29 lb bond to 110 lb cover (106 to 300 g/m ²))	LTR/STMTR	20	18	1	20	18	
		LTRR	15	13	1	15	13	
		LGL	11	10	1	11	10	
		11" x 17"	10	9	1	10	9	
		12" x 18"	9	8	1	9	8	
	13" x 19"	8	8	1	8	8		
	2-Sided (29 lb bond to 80 lb cover (106 to 220 g/m ²))	LTR/STMTR	20	18	1	20	18	
		LTRR	15	13	1	15	13	
		LGL	11	10	1	11	10	
		11" x 17"	10	9	1	10	9	
12" x 18"		9	8	1	9	8		
13" x 19"	8	8	1	8	8			
Transparency ^{*8}	1-Sided	LTR	8	8	8	-	-	

*5 Heavy 3 and Heavy 4 can only be loaded in the POD Deck Lite-A1 and Multi-Drawer Paper Deck-A1.

*6 Textured 3 and Textured 4 can only be loaded in the Multi-Purpose Tray one sheet at a time.

*7 Coated 1, Coated 2, Coated 3, and Coated 4 can only be loaded in the Multi-Purpose Tray. It is recommended to feed one sheet of coated paper at a time. When 'Speed Priority' is selected, the productivity of the paper drawers and paper decks corresponds to that of Heavy 1 and Heavy 2 for weights of 106 to 180 g/m², and Heavy 3 and Heavy 4 for weights of 181 to 300 g/m², respectively.

*8 Transparencies can only be used with a machine that is equipped with the Copy Tray-P1.



IMPORTANT

The copy/print speeds in the table above may not be achieved if the user copies/prints in the conditions below:

- If papers of differing lengths are fed together at the same time.
- If a job is printed on papers of differing paper weights.
- If a simplex or duplex job is printed on mixed media.
- If a saddle stitched booklet is created using one sheet.
- If tab paper and other paper types are used at the same time.

13.2 Mixed Paper Weight Job Productivity

The imageRUNNER ADVANCE C7260 is capable of processing jobs that contain paper with different paper weights. However, during the processing of jobs with mixed paper weights, the machine adjusts its fixing temperature, resulting in a printing delay.

13.3 Paper, Toner, and Waste Toner Replacement

The imageRUNNER ADVANCE operator can maintain productivity by removing, replacing, and refilling the paper and toner while the machine is running.

The paper trays can also be opened and refilled during operation. The tray that is being used by the machine during production, however, will be locked. Once the job completes, or the machine switches to another tray, the empty tray unlocks, allowing the operator to prepare for the next job, and add more paper. No productivity is affected and jobs finish faster.

Similar to the paper, the toner bottles can be removed and replaced while a job is printing. The imageRUNNER ADVANCE C7260 has a large toner hopper, making it possible for the machine to run longer with no bottle. The operator is not required to replace the toner bottle immediately after removing the old bottle. Therefore, productivity and image quality are not affected, and jobs finish in the same amount of time.

14. Media Usage/Compatibility

The imageRUNNER ADVANCE C7260 maintains reliable, predictable, and high-quality output. Consistency of the output is dependent on knowing and compensating for variables of a print job. The imageRUNNER ADVANCE C7260 incorporates many control systems which compensate for environmental and print process conditions. Another variable is the print media. Knowing the characteristics of the media guarantees optimal print output.

14.1 Media Characteristics by Media Library Parameters

The System Administrator must be in the Management mode to edit the media characteristics.

Characteristics	Parameters
Paper Size	Select the dimensions of the paper.
Paper Type	Select the type of paper (e.g., Plain, Tab Paper, or Pre-Punched).
Paper Weight	Select the weight of the paper in g/m ² .
Category	Select whether the paper is a Standard paper type or Custom paper type.
Finish	Select the finish of the paper (e.g., Uncoated or Coated).
Creep (Displacement) Correction	Specify the correction adjustment.

14.2 Paper Handling and Storage

- The permissible humidity range for paper storage is 30% to 70% (with a room temperature of 68°F to 80.6°F (20°C to 27°C)). Storing paper in a location that does not meet these specifications may affect paper feeding and image quality.
- Only use paper that has fully acclimatized to the environment in which the machine is installed. Using paper that has been stored in a different environment (with a different temperature and humidity), may cause paper jams or result in poor print quality.
- We recommend using paper immediately after opening the package. Rewrap any remaining paper in its original package, and store it on a flat surface.
- Before loading paper, make sure to fan the sheets thoroughly so that air runs through the sheets, as shown in the diagrams below.

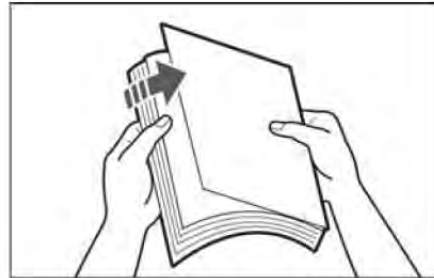
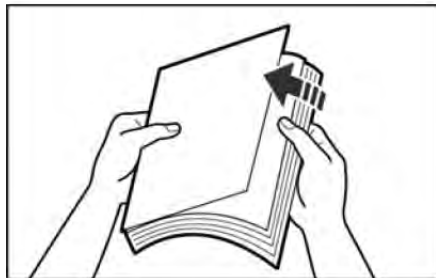

14.3 Paper Grain and Curl

Paper grain and curl can dramatically affect the reliability of machines utilizing an electrostatic process like the imageRUNNER ADVANCE C7260. Paper used in an offset press is usually cut for short edge feeding. This type of paper is not as reliable as paper made for machines utilizing an electrostatic process, which is cut for long edge feeding. Also, the composition of electrostatic paper is different from offset paper, and produces better quality results in a digital machine. When selecting paper for the imageRUNNER ADVANCE C7260 choose paper intended for use in electrostatic machines, such as laser printers and copiers.

If paper jams or poor print quality occur when paper is fed from the optional paper deck, paper curl is often the cause. The paper stiffness, direction of curl, and amount of curl have a strong influence on how well the paper is transported through the machine. If paper is curled, straighten out the paper by gently curling it in the opposite direction to which it is curled.

Paper stiffness depends on the direction of the paper grain. Paper tends to curl in the direction parallel to the grain.

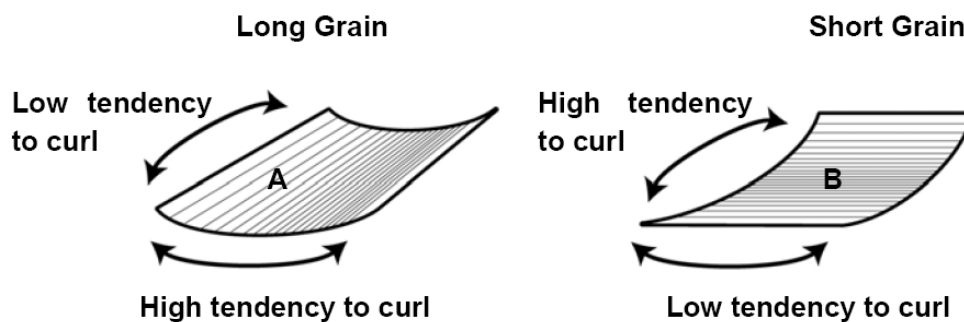

IMPORTANT

When using LTR or smaller paper sizes we recommend using paper with a grain parallel to the long edge (A). For paper sizes larger than 11" x 17", we recommend using paper with a grain parallel to the short edge (B). When using coated paper that weighs less than 105 g/m², we recommend using paper with a grain perpendicular to the feeding direction of the paper.

14.4 Note for Customers Who Cut Their Own Paper

Customers who cut their own paper may experience:

- An increase of paper dust in the machine
- Shortening the life of the machine's fixing rollers due to excessive wear from the rough side of the cut paper
- Paper jams due to paper dust getting into areas of the machine where it is not meant to be
- Improper paper feeding
- Paper registration inaccuracies

Follow the precautions below to minimize the above issues:

- Have a process in place to regularly make sure that the cutting blades are sharpened, and that cuts are made as clean as possible.
- Place the paper with the factory mill cut sides facing to the right (leading edge), and to the front of the machine.
- Pay special attention to the paper grain orientation when cutting it. For more information on paper grain, see ["Paper Grain and Curl,"](#) on p. 59.
- The best results for consistency and front to back registration are obtained by using factory mill cut, digital compatible paper.

14.5 Media Feed Locations

As with all Canon copiers, certain feed locations within the device are capable of feeding specific media sizes and weights.

When considering media, make sure the media is within the proper size and weight parameters of the feed location. Once the desired media is selected the appropriate feed location must be selected.

The default paper types registered in the machine are shown in the table below. The Paper Deck Unit-C1, POD Deck Lite-A1, Multi-Drawer Paper Deck-A1, Document Insertion Unit-H1, Document Insertion/Folding Unit-G1, and Document Insertion Unit-J1 are optional, depending on the machine.

✓ : Available - : Unavailable

Paper Type (Paper Weight)	Paper Source							
	Paper Drawers 1 and 2 (14 lb bond to 80 lb cover (52 to 220 g/m ²))	Paper Drawers 3 and 4 (14 lb bond to 80 lb cover (52 to 220 g/m ²))	Multi-Purpose Tray (14 lb bond to 110 lb cover (52 to 300 g/m ²))	Paper Deck Unit-C1 (14 lb bond to 80 lb cover (52 to 220 g/m ²))	POD Deck Lite-A1 (14 lb bond to 110 lb cover (52 to 300 g/m ²))	Multi-Drawer Paper Deck-A1 (14 lb bond to 110 lb cover (52 to 300 g/m ²))	Document Insertion Unit-H1 (14 lb bond to 110 lb cover (52 to 300 g/m ²))	Document Insertion/Folding Unit-G1 & Document Insertion Unit-J1 (16 lb bond to 140 lb index (60 to 256 g/m ²))
Thin (14 to 16 lb bond (52 to 63 g/m ²))	✓	✓	✓	✓	✓	✓	✓	✓*1
Plain 1 (17 to 21 lb bond (64 to 81 g/m ²))	✓	✓	✓	✓	✓	✓	✓	✓
Plain 2 (22 to 28 lb bond (82 to 105 g/m ²))	✓	✓	✓	✓	✓	✓	✓	✓
Recycled 1 (17 to 21 lb bond (64 to 81 g/m ²))	✓	✓	✓	✓	✓	✓	✓	✓
Recycled 2 (21 to 28 lb bond (82 to 105 g/m ²))	✓	✓	✓	✓	✓	✓	✓	✓
Color (17 to 24 lb bond (64 to 90 g/m ²))	✓	✓	✓	✓	✓	✓	✓	✓
Heavy 1 (29 to 40 lb bond (106 to 150 g/m ²))	✓	✓	✓	✓	✓	✓	✓	✓
Heavy 2 (56 to 80 lb cover (151 to 220 g/m ²))	✓	✓	✓	✓	✓	✓	✓	✓

*1 When using the Document Insertion/Folding Unit-G1 or Document Insertion Unit-J1, use paper that is at least 16 lb bond (60 g/m²).

Default Paper Types Table Continued

✓ : Available - : Unavailable

Paper Type (Paper Weight)	Paper Source							
	Paper Drawers 1 and 2 (14 lb bond to 80 lb cover (52 to 220 g/m ²))	Paper Drawers 3 and 4 (14 lb bond to 80 lb cover (52 to 220 g/m ²))	Multi-Purpose Tray (14 lb bond to 110 lb cover (52 to 300 g/m ²))	Paper Deck Unit-C1 (14 lb bond to 80 lb cover (52 to 220 g/m ²))	POD Deck Lite-A1 (14 lb bond to 110 lb cover (52 to 300 g/m ²))	Multi-Drawer Paper Deck-A1 (14 lb bond to 110 lb cover (52 to 300 g/m ²))	Document Insertion Unit-H1 (14 lb bond to 110 lb cover (52 to 300 g/m ²))	Document Insertion/Folding Unit-G1 & Document Insertion Unit-J1 (16 lb bond to 140 lb index (60 to 256 g/m ²))
Heavy 3 (82 lb cover to 140 lb index (221 to 256 g/m ²))	-	-	✓	-	✓	✓	✓	✓
Heavy 4 (140 lb index to 110 lb cover (257 to 300 g/m ²))	-	-	✓	-	✓	✓	✓	-
1-Sided Coated 1 (29 lb bond to 66 lb cover) (106 to 180 g/m ²))	-	-	✓	-	✓	✓	✓	✓
1-Sided Coated 2 (67 to 80 lb cover (181 to 220 g/m ²))	-	-	✓	-	✓	✓	✓	✓
1-Sided Coated 3 (82 lb cover to 140 lb index (221 to 256 g/m ²))	-	-	✓	-	✓	✓	✓	✓
1-Sided Coated 4 (140 lb index to 110 lb cover (257 to 300 g/m ²))	-	-	✓	-	✓	✓	✓	-

Default Paper Types Table Continued

✓ : Available - : Unavailable

Paper Type (Paper Weight)	Paper Source							
	Paper Drawers 1 and 2 (14 lb bond to 80 lb cover (52 to 220 g/m ²))	Paper Drawers 3 and 4 (14 lb bond to 80 lb cover (52 to 220 g/m ²))	Multi-Purpose Tray (14 lb bond to 110 lb cover (52 to 300 g/m ²))	Paper Deck Unit-C1 (14 lb bond to 80 lb cover (52 to 220 g/m ²))	POD Deck Lite-A1 (14 lb bond to 110 lb cover (52 to 300 g/m ²))	Multi-Drawer Paper Deck-A1 (14 lb bond to 110 lb cover (52 to 300 g/m ²))	Document Insertion Unit-H1 (14 lb bond to 110 lb cover (52 to 300 g/m ²))	Document Insertion/Folding Unit-G1 & Document Insertion Unit-J1 (16 lb bond to 140 lb index (60 to 256 g/m ²))
2-Sided Coated 1 (29 lb bond to 66 lb cover) (106 to 180 g/m ²)	-	-	✓	-	✓	✓	✓	✓
2-Sided Coated 2 (67 to 80 lb cover (181 to 220 g/m ²))	-	-	✓	-	✓	✓	✓	✓
2-Sided Coated 3 (82 lb cover to 140 lb index) (221 to 256 g/m ²)	-	-	✓	-	✓	✓	✓	✓
2-Sided Coated 4 (140 lb index to 110 lb cover) (257 to 300 g/m ²)	-	-	✓	-	✓	✓	✓	-
Textured 1 (100 to 110 lb cover) (106 to 150 g/m ²)	-	-	✓	-	✓	✓	✓	✓
Textured 2 (56 to 80 lb cover) (151 to 220 g/m ²)	-	-	✓	-	✓	✓	✓	✓

Default Paper Types Table Continued

✓ : Available - : Unavailable

Paper Type (Paper Weight)	Paper Source							
	Paper Drawers 1 and 2 (14 lb bond to 80 lb cover (52 to 220 g/m ²))	Paper Drawers 3 and 4 (14 lb bond to 80 lb cover (52 to 220 g/m ²))	Multi-Purpose Tray (14 lb bond to 110 lb cover (52 to 300 g/m ²))	Paper Deck Unit-C1 (14 lb bond to 80 lb cover (52 to 220 g/m ²))	POD Deck Lite-A1 (14 lb bond to 110 lb cover (52 to 300 g/m ²))	Multi-Drawer Paper Deck-A1 (14 lb bond to 110 lb cover (52 to 300 g/m ²))	Document Insertion Unit-H1 (14 lb bond to 110 lb cover (52 to 300 g/m ²))	Document Insertion/Folding Unit-G1 & Document Insertion Unit-J1 (16 lb bond to 140 lb index (60 to 256 g/m ²))
Textured 3 (82 lb cover to 140 lb index (221 to 256 g/m ²))	-	-	✓	-	✓	✓	✓	✓
Textured 4 (140 lb index to 110 lb cover (257 to 300 g/m ²))	-	-	✓	-	✓	✓	✓	-
Tracing Paper ² (17 to 24 lb bond (64 to 90 g/m ²))	-	-	✓	-	-	-	✓	-
Transparency ³ (40 lb bond to 66 lb cover (151 to 180 g/m ²))	✓	✓	✓	-	✓	✓	-	-
Pre-Punched (17 to 24 lb bond (64 to 90 g/m ²))	✓	✓	✓	✓	✓	✓	✓	-

*2 Use only tracing paper of the recommended weight.

*3 Use only LTR or LTRR transparencies made especially for this machine.

Default Paper Types Table Continued

✓ : Available - : Unavailable

Paper Type (Paper Weight)	Paper Source							
	Paper Drawers 1 and 2 (14 lb bond to 80 lb cover (52 to 220 g/m ²))	Paper Drawers 3 and 4 (14 lb bond to 80 lb cover (52 to 220 g/m ²))	Multi-Purpose Tray (14 lb bond to 110 lb cover (52 to 300 g/m ²))	Paper Deck Unit-C1 (14 lb bond to 80 lb cover (52 to 220 g/m ²))	POD Deck Lite-A1 (14 lb bond to 110 lb cover (52 to 300 g/m ²))	Multi-Drawer Paper Deck-A1 (14 lb bond to 110 lb cover (52 to 300 g/m ²))	Document Insertion Unit-H1 (14 lb bond to 110 lb cover (52 to 300 g/m ²))	Document Insertion/Folding Unit-G1 & Document Insertion Unit-J1 (16 lb bond to 140 lb index (60 to 256 g/m ²))
Tab 1 (40 lb bond to 66 lb cover (151 to 180 g/m ²))	-	✓	-	-	-	✓	✓	✓
Tab 2 (67 to 80 lb cover (181 to 220 g/m ²))	-	✓	-	-	-	✓	✓	✓
Labels (56 to 66 lb cover (151 to 180 g/m ²))	-	-	✓	-	✓	✓	-	-
Bond (25 to 28 lb bond (91 to 105 g/m ²))	✓	✓	✓	-	✓	✓	✓	✓
Letterhead (56 to 66 lb cover (151 to 180 g/m ²))	✓	✓	✓	✓	✓	✓	✓	✓
Envelopes	-	-	✓	-	-	-	-	-

14.6 Paper Sizes and Feed Location Chart

The table below represents the available paper sizes and feed locations. The Paper Deck Unit-C1, POD Deck Lite-A1, Multi-Drawer Paper Deck-A1, Document Insertion Unit-H1, Document Insertion/Folding Unit-G1, and Document Insertion Unit-J1 are optional, depending on the machine.

✓: Available - : Unavailable

Paper Size	Width x Length	Paper Source							
		Paper Drawer 1 & 2	Paper Drawer 3 & 4	Multi-Purpose Tray	Paper Deck Unit-C1	POD Deck Lite-A1	Multi-Drawer Paper Deck-A1	Doc. Insert. Unit-H1	Document Insertion/Folding Unit-G1 & Document Insertion Unit-J1
13" x 19"	13" x 19"	-	✓	✓	-	✓	✓	✓	✓
12 5/8" x 17 11/16"	12 5/8" x 17 11/16"	-	✓	✓	-	✓	✓	✓	✓
12" x 18"	12" x 18"	-	✓	✓	-	✓	✓	✓	✓
11" x 17"	11" x 17"	-	✓	✓	-	✓	✓	✓	✓
LGL	8 1/2" x 14"	-	✓	✓	-	✓	✓	✓	✓
LTR	8 1/2" x 11"	✓	✓	✓	✓	✓	✓	✓	✓
LTRR	11" x 8 1/2"	-	✓	✓	-	✓	✓	✓	✓
STMTR	5 1/2" x 8 1/2"	-	✓	✓	-	-	✓	-	-
EXEC	7 1/4" x 10 1/2"	-	✓	✓	-	-	✓	✓	✓
Custom Size	4" x 5 7/8" to 13" x 19 1/4" (100 mm x 148 mm to 330.2 mm x 487.7 mm)	-	✓ ^{*1}	✓	-	-	✓ ^{*1}	✓ ^{*2}	-

*1 Custom paper sizes can only be fed from these paper sources if they are between 5 1/2" x 7 1/8" and 13" x 19 1/4" (139.7 mm x 182 mm and 330.2 mm x 487.7 mm).

*2 Custom paper sizes can only be fed from these paper sources if they are between 7 1/8" x 7 1/8" and 13" x 19 1/4" (182 mm x 182 mm and 330.2 mm x 487.7 mm).

Paper Sizes and Feed Location Table Continued

✓ : Available - : Unavailable

Paper Size		Width x Length	Paper Source							
			Paper Drawer 1 & 2	Paper Drawer 3 & 4	Multi-Purpose Tray	Paper Deck Unit-C1	POD Deck Lite-A1	Multi-Drawer Paper Deck-A1	Doc. Insert. Unit-H1	Doc. Insert./ Fold. Unit-G1 & Doc. Insert. Unit-J1
Envelope	ISO-C5	6 3/8" x 9" (162 mm x 229 mm)	-	-	✓	-	-	-	-	-
	COM 10 (No. 10)	4 1/8" x 9 1/2" (104.7 mm x 241.3 mm)	-	-	✓	-	-	-	-	-
	Monarch	3 7/8" x 7 1/2" (98.4 mm x 190.5 mm)	-	-	✓	-	-	-	-	-
	DL	4 3/8" x 8 5/8" (110 mm x 220 mm)	-	-	✓	-	-	-	-	-
	Nagagata 3/ Yougatanaga 3	4 3/4" x 9 1/4" (120 mm x 235 mm)	-	-	✓	-	-	-	-	-
	Kakugata 2 (Horizontally placed)	9 1/2" x 13 1/2" (240 mm x 332 mm)	-	-	✓	-	-	-	-	-
	Kakugata 2 (Vertcially placed)	13 1/2" x 9 1/2" (332 mm x 240 mm)	-	-	✓	-	-	-	-	-
	Custom Size	5 1/2" x 7 1/8" to 13" x 17" (139.7 mm x 182 mm to 330.2 mm x 432.1 mm)	-	-	✓	-	-	-	-	-



NOTE

For instructions on loading and orientating paper, see the *Maintenance e-Manual*.

15. Image Quality Capabilities

The table below describes the type of image quality the customer can expect when using the machine.



IMPORTANT

Following installation and set up, it is strongly recommended that owners of the imageRUNNER ADVANCE C7260 print and store samples of the image quality the product is capable of producing. These samples should serve as a benchmark against which subsequent image quality can be referenced. Samples should be made using as many applications, media, and paper types the owner intends to use on the imageRUNNER ADVANCE C7260.

Item	Equipment Capability	Comment
Overall Document Appearance	No three dimensional appearance. Has look and feel of offset printing. Uniform look and feel.	
Color Uniformity	Color and images are uniform throughout the document. Gradations are smooth and even.	The most demanding customers may occasionally perceive a small amount of mottling in large uniform image areas. Extreme high-humidity conditions can lead to mottling. If the customer requires excellent uniformity, make sure that they follow an aggressive maintenance schedule, and operate the machine within the machine's environmental requirements.
Color & Image Quality Consistency/Stability	Color and image quality is consistent throughout the document, and from one document to another.	
Color Matching	Capable of rendering many of the Pantone color swatches that are used in the graphic arts industry.	
Line Quality	Even and fine lines can be reproduced.	Extreme high-humidity conditions can lead to the break up or blurriness of lines.
Black Reproduction	Blacks are well saturated without mottling.	Extreme high-humidity conditions can lead to mottling.
Text Quality	Sharp, well defined text. No hollow characters or haloing of text characters.	Extremely high-humidity conditions can lead to hollow or the haloing of characters.
Background Level	Stray toner in non-image areas is unperceivable.	Environmental conditions, such as low-humidity, can increase toner levels in the background.
Other Artifacts	As with any printing process, some artifacts, such as spots, void or deleted areas, mottling, streaks, and banding may occur. But, these artifacts are not significant for most users.	Proper servicing of the equipment and adherence to media and environmental requirements help minimize these occurrences.

15.1 Customer-Defined Image Quality Adjustments and Recommendations

Customer-defined image quality adjustments enable the customer to enhance the productivity of the machine. There are several user modes, such as the Adjust Image Quality and Paper Type Management Settings modes, which provide adjustment functions, to help maintain the desired image quality for each job. These settings also aim at reproducing optimal images under variable factors (i.e., changes in the environment, deterioration due to aging, etc.).

To achieve the best image quality the following factors are recommended:

- Tighter control of the temperature and humidity will result in tighter image quality consistency in the device.
- The device must be properly maintained, which includes performing preventative maintenance as scheduled.
- To maintain proper color calibration on the device, the customer should perform a Shading Correction and a Full Auto Gradation Adjustment once a day and whenever a change in print quality is noticed. Follow these guidelines to calibrate the machine properly:
 - When calibrating the machine, make sure to perform a shading correction first, then an Auto Gradation Adjustment on the engine, and then a calibration with the RIP.
 - If an EFI controller is being used, use a high-quality, 28 lb bond (105 g/m²), 98% brightness, 11" x 17" or LTR sized paper when performing an Auto Gradation Adjustment.
 - If the Canon controller or off the glass copying is being used, the user must calibrate the machine to the paper being used. For example, Heavy 1/2 or Heavy 3/4 paper. Once a job is complete, it is recommended to recalibrate the machine using a high-quality, 28 lb bond (105 g/m²), 98% brightness, 11" x 17" or LTR sized paper.

15.1.1 Adjust Image Quality Modes

The Adjust Image Quality mode enables the user to make fine adjustments to the printed image. For more information on specifying the Adjust Image Quality modes, see “Adjustment/Maintenance,” in the *Settings/Registration e-Manual* included with the machine.

The following items can be adjusted through the Adjust Image Quality menu:

- Auto Adjust Gradation
- Correct Shading
- Fine Adjust Zoom
- Correct Density
- Auto Correct Color Mismatch
- Color Balance



IMPORTANT

- It is recommended that the user select [Full Adjust] when performing an automatic gradation adjustment. Select [Quick Adjust] to perform a quick, but less complete adjustment between regular full adjustment recalibrations.
- If the Correct Shading mode is specified, only 12 5/8” x 17 11/16”, 12” x 18”, 11” x 17”, or LTR plain paper can be used for the test pages. Make sure that a sufficient supply of the aforementioned paper sizes is loaded in a paper source before starting the Correct Shading procedure.

15.1.2 Paper Type Management Settings

The Paper Type Management Settings mode enables the System Administrator to improve the image quality output result by precisely registering the type of custom or standard paper settings that are frequently used in the machine.

The following items can be adjusted through the Paper Type Management Settings menu:

- Basis Weight
- Type
- Adjust Creep Correction
- Adj. Ppr. Separation Fan Level
- Adj. Secondary Transfer Volt
- Finish
- Color
- Curl Correction Level
- Adjust Image Position
- Tail End White Patch Correct.



IMPORTANT

- The Paper Type Management Settings mode is only available from the Management mode.
- For more information on specifying the Paper Type Management Settings modes, see “Registering/Editing Custom Paper Types,” in the *Settings/Registration e-Manual* included with the machine.

16. Responsibility Matrix

Action	Responsibility	
	Customer	Dealer
Ensure adequate space and power to properly install the machine.		
Verify floor strength and level.		
Ensure that the equipment can be delivered to the site, and that the path is clear and unobstructed.		
Unpack all delivered items.		
Install all system hardware.		
Connect all system components.		
Install printer files and server.		
Ensure network configuration, and confirm that the device is attached to the network.		
Install client workstation network software.		
Order and replace, as necessary, replaceable items (i.e., drum cartridges, toner, etc.).		
Order and replace the waste toner container, as necessary.		
Provide technical support.		
Provide on-site support.		
Establish an installation file of a typical job, and retain for future reference.		
Perform a Correct Shading procedure once a day.*1		
Perform an Auto Gradation Adjustment once a day.*1		
Back up important data, such as Inbox and Address Book contents on the machine's hard drive periodically.		
Secure data stored on hard drives and in the Advanced Box.		
Storage of the TPM encryption key (if TPM setting is set to 'On').		

*1 For more information, see "Adjustment/Maintenance," in the *Settings/Registration e-Manual* included with the machine.

Primary customer applications for using this equipment:

Special considerations or performance limitations:

I have received a copy of this document.

Customer:

Sales Person:
