

# Canon imageFORMULA Document Scanner DR-3010C

## Easy Start Guide

Thank you for purchasing the Canon imageFORMULA DR-3010C.

The manuals for this scanner are made up of the "Easy Start Guide" (this manual), "Reference Guide", and the digital manuals of the "User Manual" and "CapturePerfect 3.0 Operation Guide" included on the setup disc. Before you use this scanner, make sure to thoroughly read these manuals and understand them. After you have finished reading these manuals, store them in a safe place for future reference.

**Easy Start Guide (This Manual)**  
This contains the procedures to setup the scanner for use. Follow these procedures to setup your scanner.

**Reference Guide**  
This manual outlines the specific items for using your scanner. For details refer to the User Manual.

**User Manual (Digital Manual)**  
This manual describes the overall handling of the scanner from setup to use, maintenance and troubleshooting, the ISIS/TWAIN driver for using the scanner, and the Job Registration Tool.

**CapturePerfect 3.0 Operation Guide (Digital Manual)**  
This manual is the operations guide for the Canon document scanner application, CapturePerfect 3.0.

The digital manuals are document files in the PDF (Portable Documents Format) format. The software installed registers the manuals in the following location.

(STEP3)

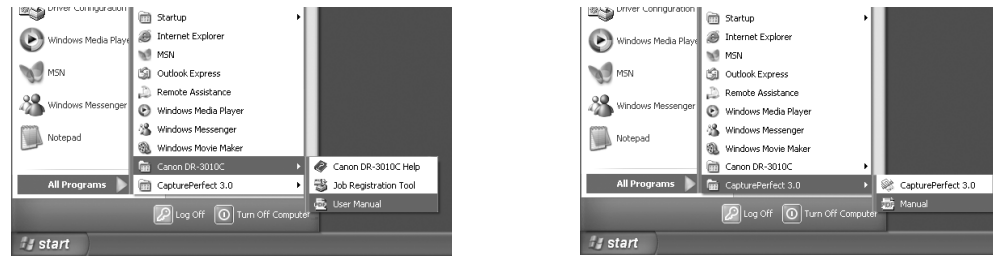

User Manual

CapturePerfect 3.0 Operation Guide

## STEP 1 Checking the Accessories

When you unpack your scanner, make sure that it contains all of the following accessories. If any of the items listed below are missing or damaged, contact your local authorized Canon dealer or service representative.

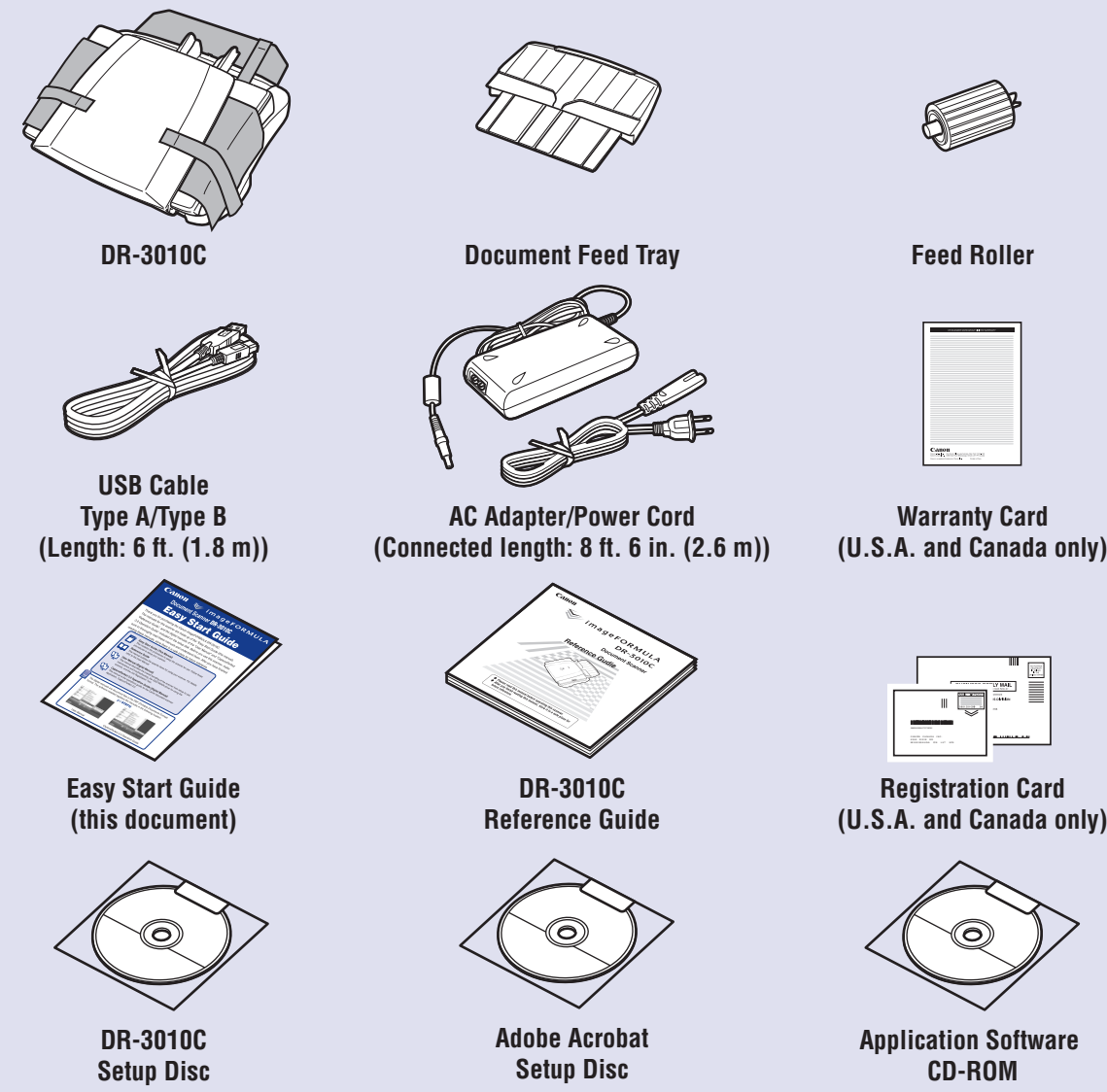

- The Feed Roller is used by loading it into the DR-3010C. (STEP2)
- Items included in this manual are subject to change without notice.
- You must keep the machine's packaging and packing materials for storing or transporting the machine.

Trademarks  
Canon and the Canon logo are registered trademarks of Canon Inc. in the United States and may also be trademarks or registered trademarks in other countries.  
Microsoft Windows is a registered trademark of Microsoft USA in the United States and other countries.  
Other brands and product names used in this manual may be trademarks or registered trademarks of their respective companies.

**Memo**  
The following application software is included on the application software disc that comes with this product. See Readme.txt for information on installing the software.

- Presto! BizCard Reader 5 SE  
Name card management software provided with the multi-language OCR made by NewSoft Technology Corp.
- OmniPage SE 4\*  
Optical character recognition (OCR) software with multiple language support, made by Nuance Communications Inc.
- PaperPort® 11\*  
File management application that makes it easy to store, organize, and retrieve digital documents, made by Nuance Communications Inc.

\* In order to receive support of this product, you need to upgrade to a professional version. Please see following URL for upgrade.  
<http://www.nuance.com/partneroffer/canon>

After checking the package contents, you need to prepare the scanner for use. (STEP2)

## STEP 2 Removing the Packing Materials and Installing the Feed Roller

Remove the scanner from the box, remove the orange tape and protective sheets from the scanner, and install the feed roller on the scanner body.

1. Peel the pieces of orange tape holding the document eject tray (▼).

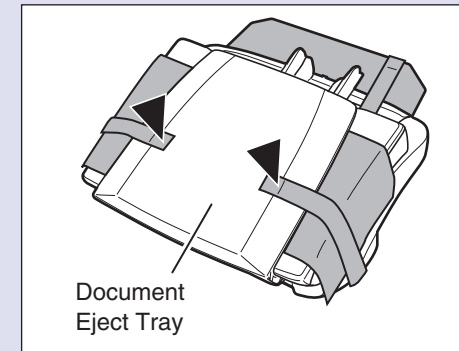

2. Open the document eject tray, and remove the protective sheet (▼).

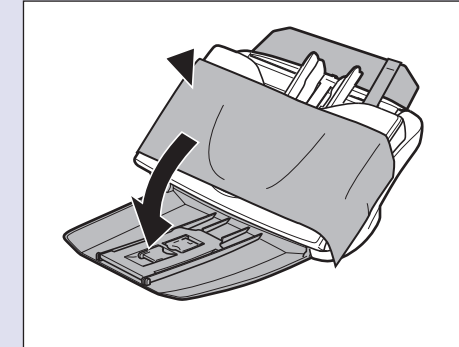

3. Press the OPEN button (1) while pulling the front unit open (2).

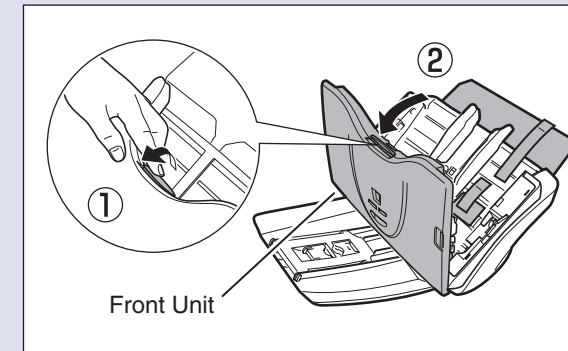

4. Remove the orange tape and protective materials.

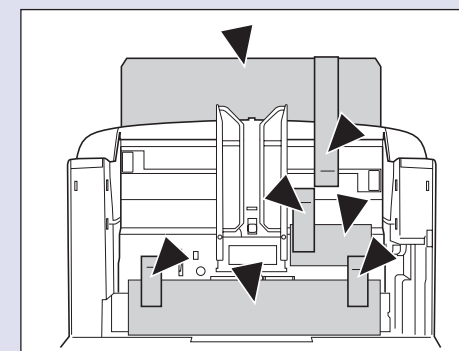

5. Push the document holding guides to each side, and open the roller cover on the main unit by placing your fingers in the grooves and pulling it down.

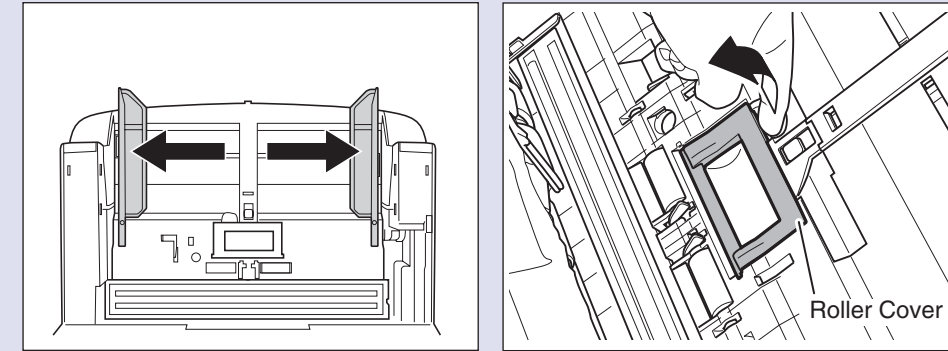

6. Lift up the roller fixing lever (1), and slide it (2).

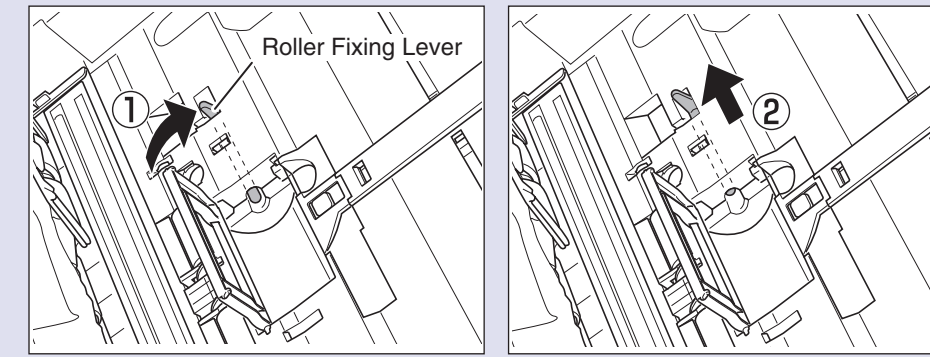

7. Insert the feed roller into the slot inside the roller cover, and align the notch on the roller with the shaft on the main unit.

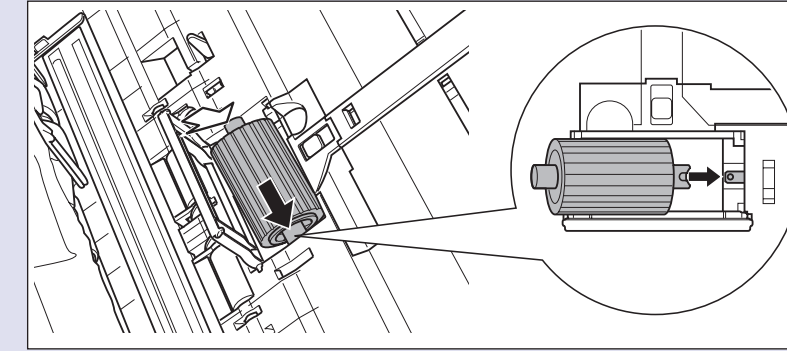

8. Slide the roller fixing lever to the right to lock the roller into the hole on the left of the feed roller (1). Push down the lever to lock the shaft of the feed roller into place (2).

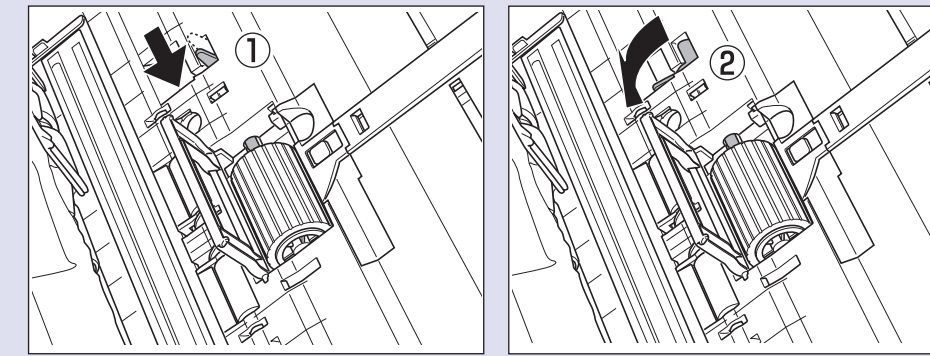

9. Close the roller cover. Make sure that the cover is completely closed by pushing until you hear a click.

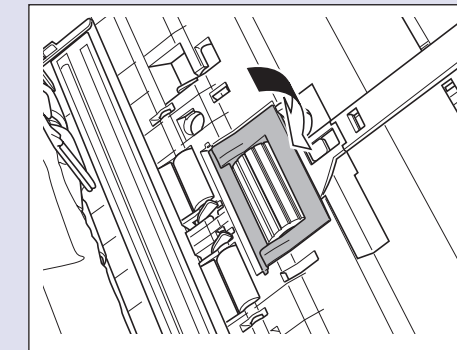

10. Close the front unit by gently pushing it up on both sides until it clicks into place. Make sure that the front unit is completely closed by pushing until you hear a click.

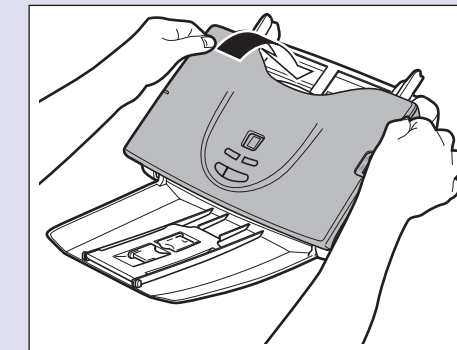

11. Close the document eject tray.

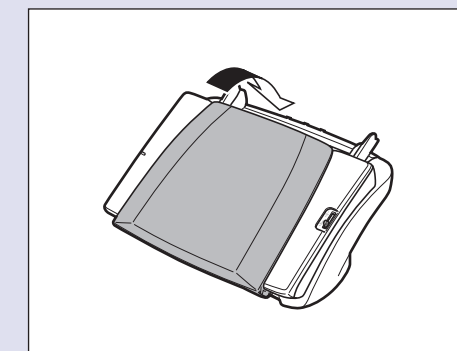

12. Insert the document feed tray until it clicks into place.

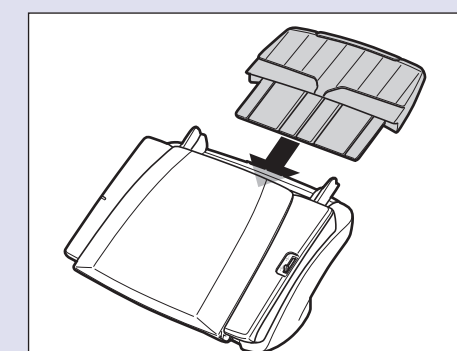

The scanner is now ready for use.  
Next, you need to install the scanner software. (STEP3)

## STEP 3 Installing the Software

Install the software before connecting the scanner to the computer.

**Caution**  
Before installing the software, make sure your computer is correctly running one of the following versions of Windows. For details, refer to the DR-3010C Reference Guide.

- Windows 2000 Professional SP4 or later
- Windows XP Home Edition SP3 or later
- Windows XP Professional SP3 or later
- Windows XP Professional x64 Edition SP2 or later
- Windows Vista Home Basic (32-bit, 64-bit) SP1 or later
- Windows Vista Home Premium (32-bit, 64-bit) SP1 or later
- Windows Vista Business (32-bit, 64-bit) SP1 or later
- Windows Vista Ultimate (32-bit, 64-bit) SP1 or later
- Windows Vista Enterprise (32-bit, 64-bit) SP1 or later

Do not connect the scanner to the computer before installing the software. If you connect the scanner and turn it ON before you install the software, the wizard screen below will appear. If this wizard is displayed, click the [Cancel] button to exit the wizard, and turn the scanner OFF. (STEP4)

Wizard Screen (Windows XP)

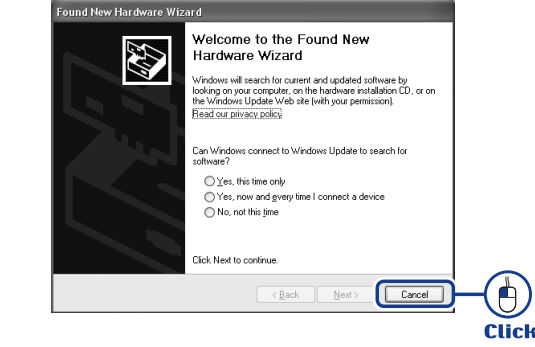

Close all other applications before installing the software.

1. Log on to Windows with an account that has administrator privileges.

2. Insert the DR-3010C Setup Disc into the PC's CD-ROM drive. The setup wizard automatically starts up when you insert the CD-ROM into the CD-ROM drive. If the setup wizard does not start up, execute setup.exe in the CD-ROM.

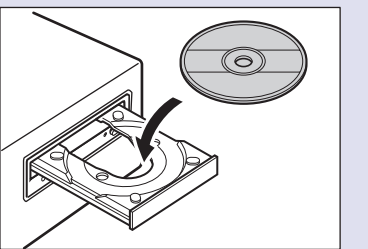

For Windows Vista

When using Windows Vista, the "User Account Control" screen may appear. In this case, log on as an administrator and click [OK].

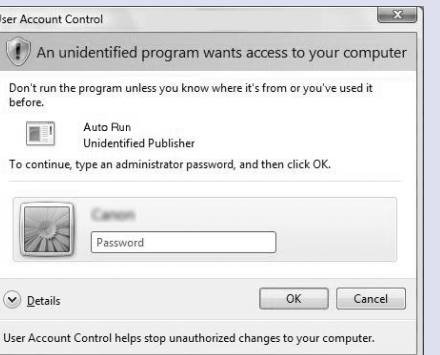

The DR-3010C setup menu is constructed of the following screens:

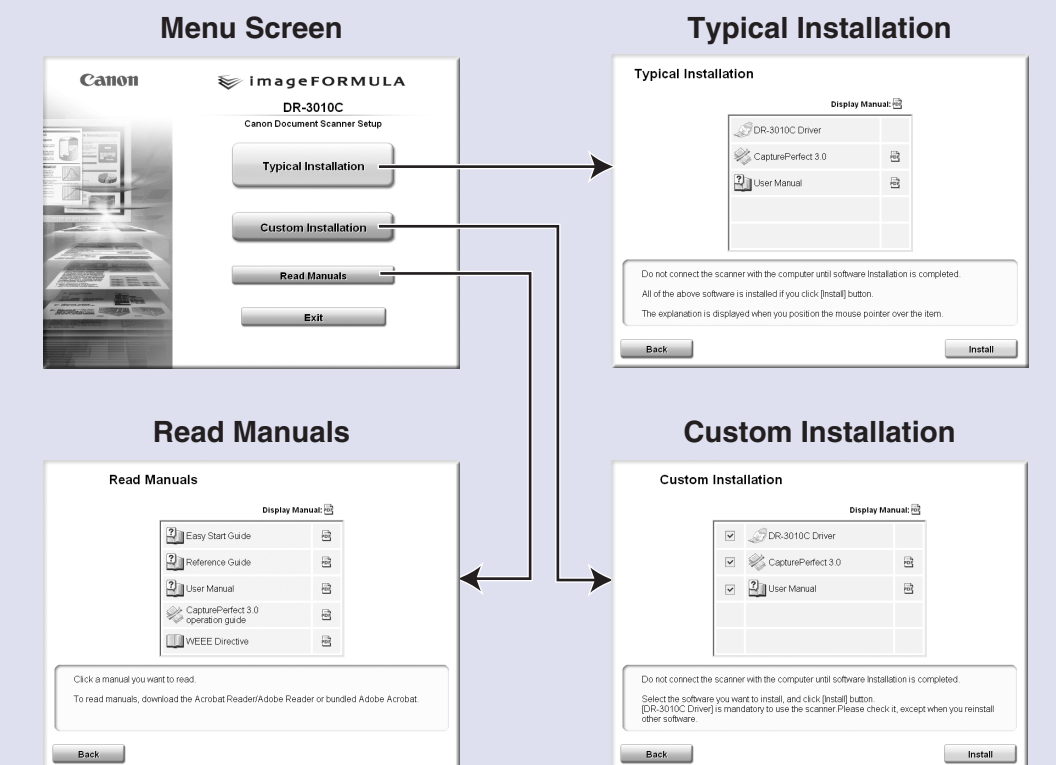

3. Click [Typical Installation]. If you click [Typical Installation], the software (DR-3010C driver, CapturePerfect 3.0), and the User Manual are installed.

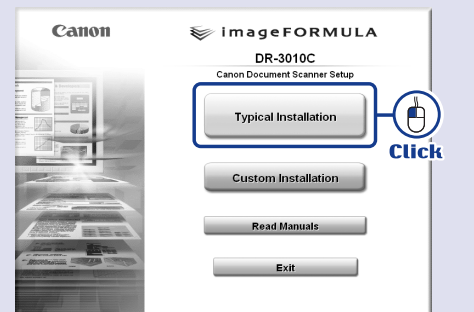

The CapturePerfect Operation Guide is installed on your computer by the CapturePerfect installation.

4. Click [Install].  
The DR-3010C driver installation is executed. During the DR-3010C driver installation, the DR-3010C driver and the Job Registration Tool are installed.

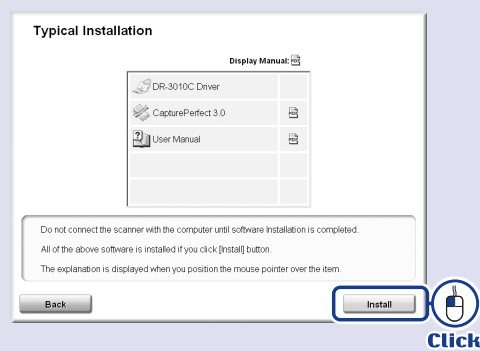

5. Click [Next].

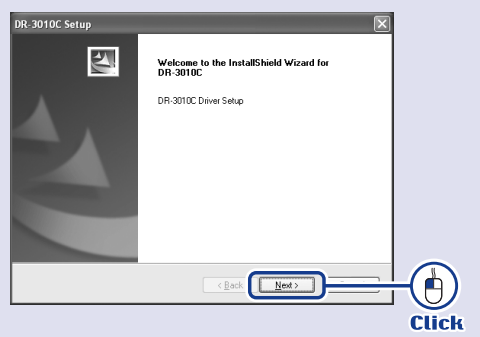

6. Read the software license agreement, and click [Yes] if you consent to the conditions of the software.  
Installation of the scanner driver starts.

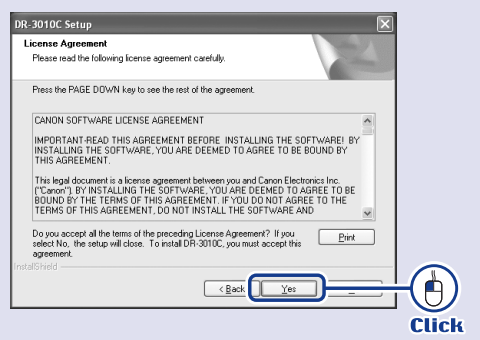

7. Click [Finish] to complete the installation of DR-3010C driver.

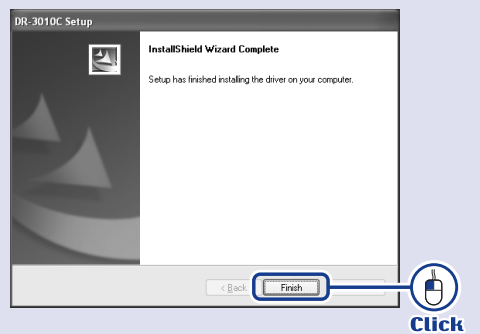

Next, the installation wizard for CapturePerfect 3.0 appears.

8. Click [Next].

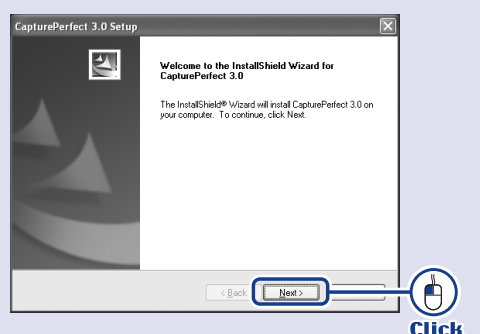

9. Read the software license agreement, and click [Yes] if you consent to the conditions of the software.

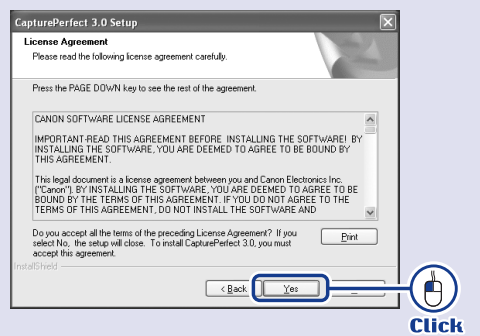

10. Check the destination folder and click [Next].  
Installation of CapturePerfect 3.0 starts.

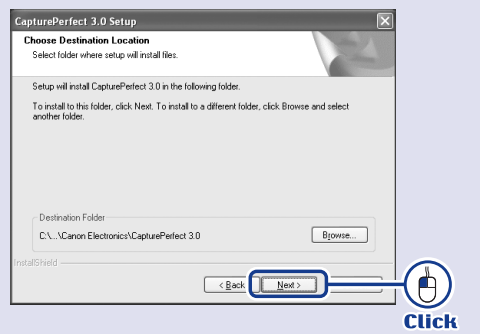

11. Click [Finish] to complete the installation of CapturePerfect 3.0.  
Next, the User Manual installation wizard appears.

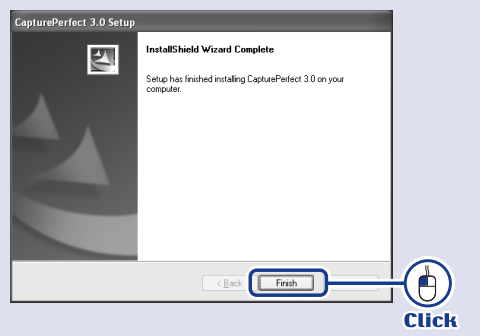

12. Click [Next].  
Installation of the User Manual starts.



13. Click [Finish] to complete the installation of the User Manual.

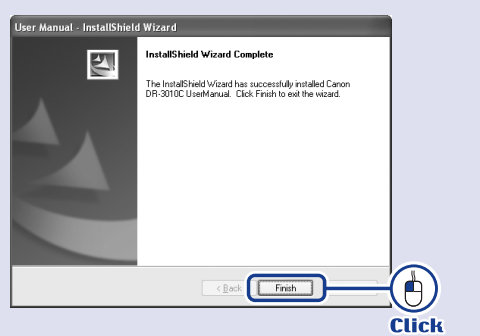

14. When all installations are complete, the Installation completed screen appears. Click [Exit] to exit the installer. (Click [Back] to return to the menu screen.)

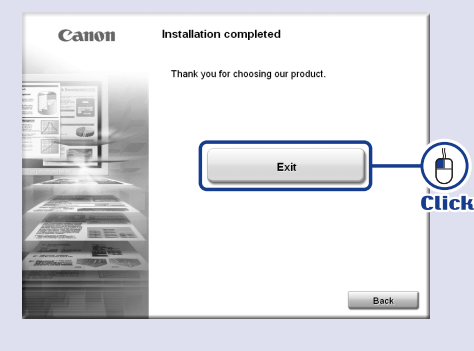

This completes the software installation.  
Next, you need to connect the scanner to your computer. (STEP4)

## STEP 4 Connecting the Scanner to Your PC

Perform the following steps to connect the scanner to your PC with a USB cable.

- Caution**
- Use only the AC adapter and power cord included in this package.
  - Connect the DR-3010C to your computer while the DR-3010C is turned OFF.

- Check that the power switch is in the "O" (OFF) position (1). If the power switch is in the "I" (ON) or "AUTO" position, switch it to "O" (OFF).
- Connect the power cord to the AC adapter (2).
- Plug the AC adapter into the connector located on the back side of the machine (3).
- Plug the power cord into the power outlet (4).

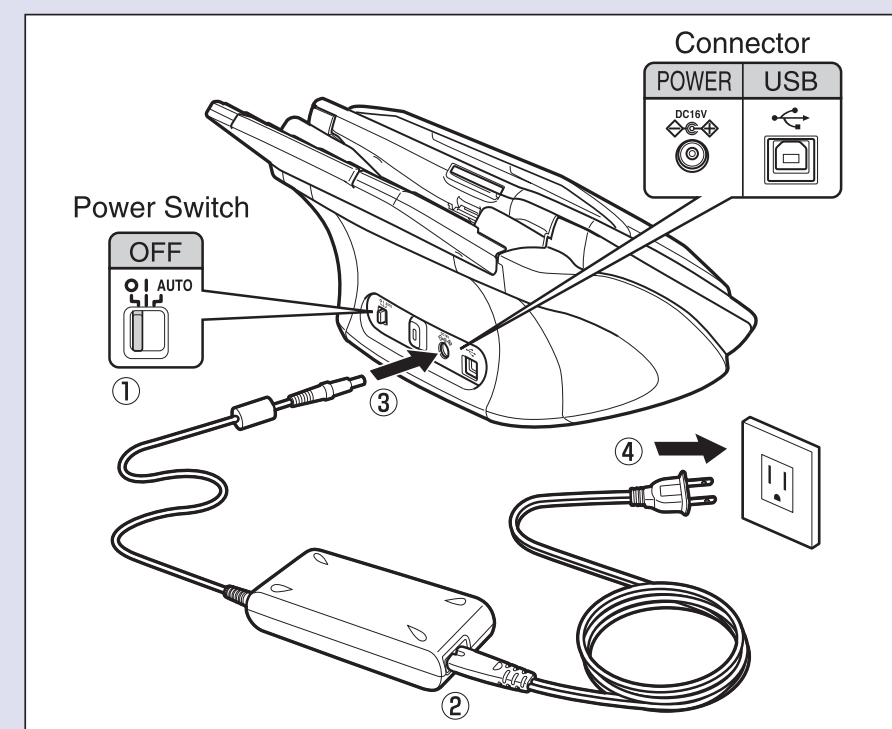

- Connect the USB cable included with the scanner to the scanner and your PC.

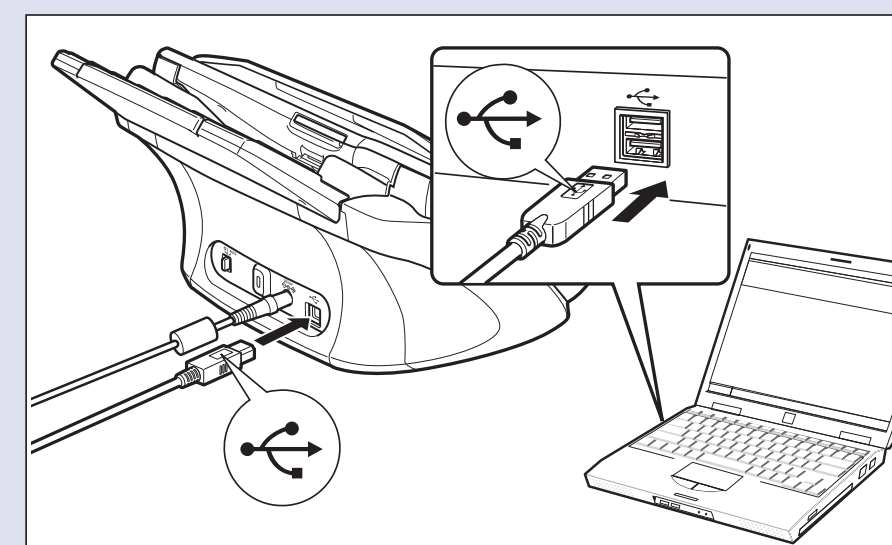

The scanner and computer are connected.  
Next, turn the scanner ON and Windows recognizes it. (STEP5)

## STEP 5 Turning the Scanner Power ON (Scanner Recognition)

When you turn the scanner connected to the PC ON, the plug-and-play function recognizes the scanner, and the device driver is automatically installed.

- Caution**
- Be sure to log on with administrator privileges when logging on to Windows.

- Make sure that the scanner and computer are connected.
- Turn the power switch of the scanner to "I" (ON) or "AUTO".  
ON: The power of the scanner is turned ON, and the power indicator is lit blue.  
AUTO: The power of the scanner is turned ON/OFF when the power of the computer is turned ON/OFF.

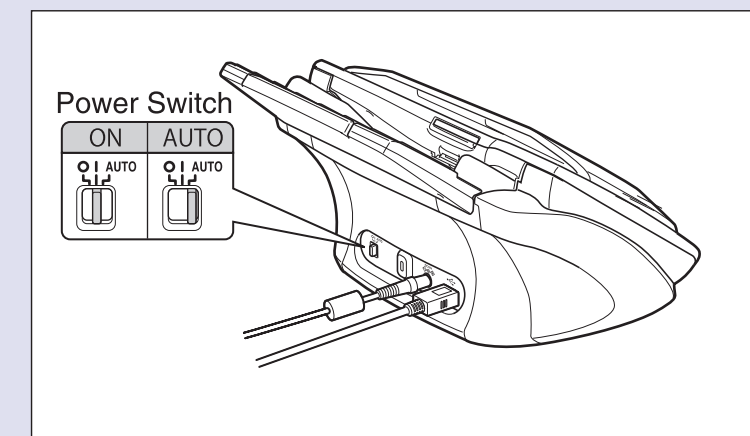

- Turn ON your computer.
- Windows automatically recognizes the DR-3010C as new hardware.



- Memo**
- In Windows Vista, installation is complete even if the "Click here for status." help bubble does not appear. Click "Click here for status." to display the installation progress.



- When installation is finished, a message appears in the help bubble.



The scanner is now correctly recognized by your computer.  
Next, check whether you can actually scan. (STEP6)

## STEP 6 Scanning

When you have finished installing the software and the scanner has been recognized, you can load and scan a document.

The DR-3010C can perform scanning by simply pressing the Start key on the operation panel. Follow the steps below to load a document, press the Start key, and confirm that your document is scanned properly.

- Open the document eject tray.

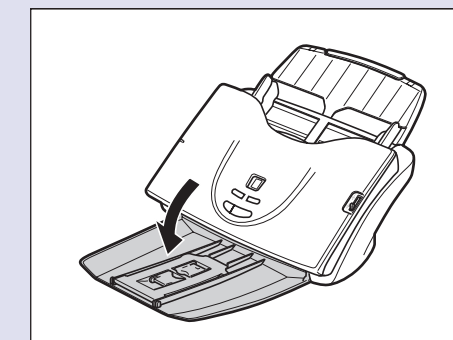

- Confirm the feed selection lever is set to 1. Be careful, because when the feed selection lever is set to 2 (bypass mode), document pages feed without being separated. For details on the feed selection lever, refer to the DR-3010C User Manual.

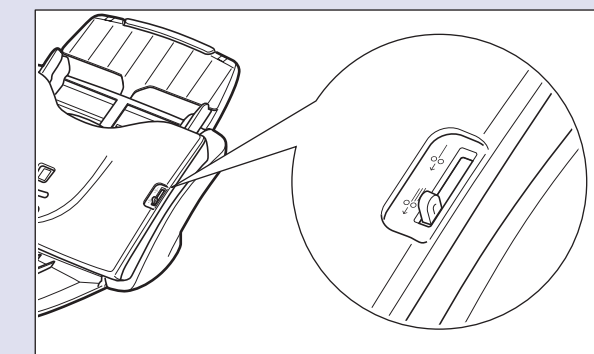

- Thoroughly fan the pages of your documents, and shift the pages so that the top edge of the first page is the bottommost page.

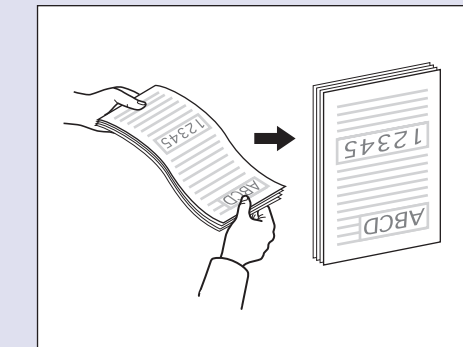

- Place the document with the reverse side facing you, and the top of the document so it is fed through the scanner first. Adjust the document guides to fit the width of the document.

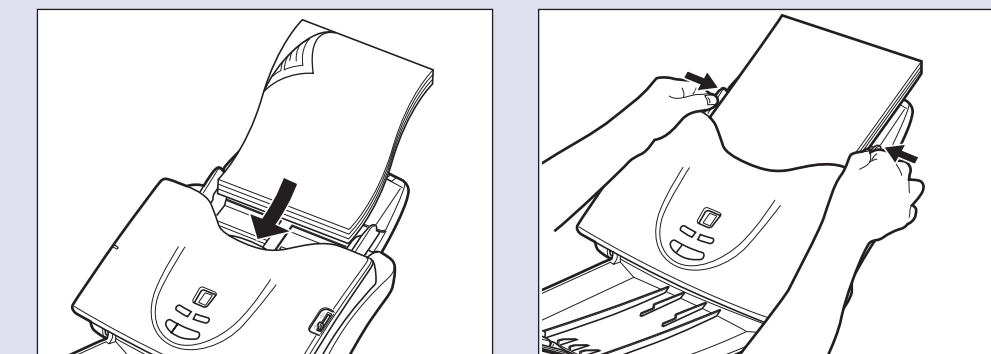

- Confirm the job number "1" is displayed on the display panel (1), and then press the Start key (2). "Monitor for DR-3010C" is displayed at the bottom right of the screen and scanning starts.

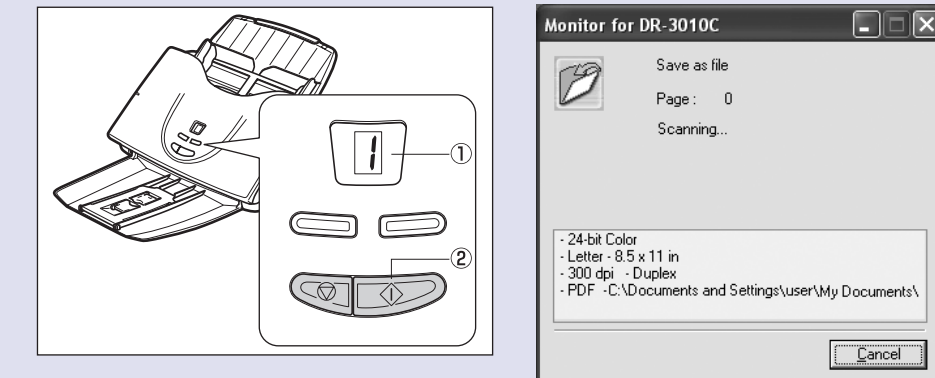

- When "Sending complete" is displayed on the "Monitor for DR-3010C", this indicates that scanning has ended. Click "Close" to close the "Monitor for DR-3010C".



- Memo**
- The initial settings for the functions assigned to each job number are as follows:  
Job Number 1: Scan To Folder (Saves the scanned image)  
Job Number 2: Scan To Mailer (Attaches the scanned image to an e-mail)
  - The function assigned to each job number can be changed. For details, see "Scanning with the Job Function," in the User Manual.
  - Scanned image files are saved in the [My Pictures] folder in [My Documents]. (Default)
  - Image files that are saved according to the default settings are saved as PDF files with a 17-digit file name. This file name indicates the date and time that the image was saved.
  - You can change the scan settings with the Job Function by using the Job Registration Tool registered in the Programs menu.

The setup of the DR-3010C is now complete.

- This completes the setup of the DR-3010C. Before you start using the DR-3010C, be sure to thoroughly read the DR-3010C User Manual and Reference Guide.
- For information on using CapturePerfect 3.0, refer to the operation guide registered in the Programs menu.