

# **Super G3 FAX Board-AB1**

# **SERVICE MANUAL**

**Canon**

**October 29, 2010  
Rev. 1**



## Application

This manual has been issued by Canon Inc. for qualified persons to learn technical theory, installation, maintenance, and repair of products. This manual covers all localities where the products are sold. For this reason, there may be information in this manual that does not apply to your locality.

## Corrections

This manual may contain technical inaccuracies or typographical errors due to improvements or changes in products. When changes occur in applicable products or in the contents of this manual, Canon will release technical information as the need arises. In the event of major changes in the contents of this manual over a long or short period, Canon will issue a new edition of this manual.

The following paragraph does not apply to any countries where such provisions are inconsistent with local law.

## Trademarks

The product names and company names used in this manual are the registered trademarks of the individual companies.

## Copyright

This manual is copyrighted with all rights reserved. Under the copyright laws, this manual may not be copied, reproduced or translated into another language, in whole or in part, without the written consent of Canon Inc.

***COPYRIGHT © 2001 CANON INC.***

*Printed in Japan*

## Caution









Use of this manual should be strictly supervised to avoid disclosure of confidential information.

---

# Symbols Used



---

This documentation uses the following symbols to indicate special information:

Symbol	Description
	Indicates an item of a non-specific nature, possibly classified as Note, Caution, or Warning.
	Indicates an item requiring care to avoid electric shocks.
	Indicates an item requiring care to avoid combustion (fire).
	Indicates an item prohibiting disassembly to avoid electric shocks or problems.
	Indicates an item requiring disconnection of the power plug from the electric outlet.
 Memo	Indicates an item intended to provide notes assisting the understanding of the topic in question.
 REF.	Indicates an item of reference assisting the understanding of the topic in question.
	Provides a description of a service mode.
	Provides a description of the nature of an error indication.

The following rules apply throughout this Service Manual:

1. Each chapter contains sections explaining the purpose of specific functions and the relationship between electrical and mechanical systems with reference to the timing of operation.

In the diagrams,  represents the path of mechanical drive; where a signal name accompanies the symbol, the arrow  indicates the direction of the electric signal.

The expression "turn on the power" means flipping on the power switch, closing the front door, and closing the delivery unit door, which results in supplying the machine with power.

2. In the digital circuits, '1' is used to indicate that the voltage level of a given signal is "High", while '0' is used to indicate "Low". (The voltage value, however, differs from circuit to circuit.) In addition, the asterisk (\*) as in "DRMD\*" indicates that the DRMD signal goes on when '0'.

In practically all cases, the internal mechanisms of a microprocessor cannot be checked in the field. Therefore, the operations of the microprocessors used in the machines are not discussed: they are explained in terms of from sensors to the input of the DC controller PCB and from the output of the DC controller PCB to the loads.

The descriptions in this Service Manual are subject to change without notice for product improvement or other purposes, and major changes will be communicated in the form of Service Information bulletins.

All service persons are expected to have a good understanding of the contents of this Service Manual and all relevant Service Information bulletins and be able to identify and isolate faults in the machine."



---

# Contents

## Chapter 1 Specifications

1.1 Product Specifications .....	1- 1
1.1.1 FAX Specifications .....	1- 1

## Chapter 2 Installation

2.1 Unpacking and Checking the Components .....	2- 1
2.1.1 Checking Contents .....	2- 1
2.2 Installation Procedure .....	2- 1
2.2.1 Turning OFF Power .....	2- 1
2.2.2 Installation Procedure .....	2- 1
2.2.3 After Installation .....	2- 5
2.3 Attaching the Labels etc. ....	2- 5
2.3.1 Putting Labels .....	2- 5
2.4 Checking the Operation .....	2- 5
2.4.1 Type Settings .....	2- 5
2.4.2 Line Type Setting .....	2- 5
2.4.3 FAX Communication Test .....	2- 5

## Chapter 3 Functions

3.1 Basic Construction .....	3- 1
3.1.1 Overview .....	3- 1

## Chapter 4 Parts Replacement Procedure

4.1 Removing from the Host Machine .....	4- 1
4.1.1 FAX Unit .....	4- 1
4.1.1.1 Pre-operation .....	4- 1
4.1.1.2 Removing the NCU PCB .....	4- 3
4.1.1.3 Removing the Off Hook PCB .....	4- 3

## Chapter 5 Service Mode

5.1 Outline .....	5- 1
5.1.1 Service Mode Configuration .....	5- 1
5.1.2 Exiting Service Mode .....	5- 3
5.1.3 Service Mode Backup .....	5- 3
5.1.4 Service Mode Backup .....	5- 4
5.2 Setting of Bit Switch (SSSW) .....	5- 6
5.2.1 Outline .....	5- 6
5.2.1.1 SSSW List .....	5- 6
5.3 Setting of Menu Switch (MENU) .....	5- 7
5.3.1 MENU List .....	5- 7
5.4 Setting of Numeric Parameter (NUMERIC Param.) .....	5- 7
5.4.1 NUM List .....	5- 7





---

## Chapter 1 Specifications

---



# Contents

1.1 Product Specifications.....	1-1
1.1.1 FAX Specifications.....	1-1



## 1.1 Product Specifications

### 1.1.1 FAX Specifications

T-1-1

<b>Model</b>	Super G3 Fax Board-AB1
<b>Applicable lines</b>	Public Switched Telephone Network (PSTN) * PSTN currently supports the modem speed of up to 28.8Kbps. It, however, differs depending on the telephone line condition.  Number of lines connected: 1
<b>Transmission method</b>	G3
<b>Modulation method</b>	Image modulation: V.34/V.17/V.29/V.27ter Transmission procedure: V.21
<b>Transmission speed</b>	Transmission speed: Approx. 3 sec per page ECM-JBIG, Transmitted from memory at 33.6Kbps * Based on the JBIG standard mode with ITU-T standard chart No. 1  Modem speed: 33,600bps, Automatic fallback
<b>Coding</b>	Compression method: JBIG, MMR, MR, MH
<b>Error correction</b>	ECM
<b>Scanning line density</b>	Reading: 8x 3.85/7.7/15.4 16x15.4 Recording: 600 x 600dpi
<b>Scanning density adjustment</b>	9 levels, manual adjustment
<b>Half tone</b>	256 gradation
<b>Printing resolution</b>	Resolution conversion: Provided  <200 x 100dpi>: 8 pixels/mm x 3.85 lines/mm <200 x 200dpi>: 8 pixels/mm x 7.7 lines/mm <200 x 400dpi>: 8 pixels/mm x 15.4 lines/mm <400 x 400dpi>: 16 pixels/mm x 15.4 lines/mm
<b>Reduction for reception</b>	Automatic reduction of an image received: 75 to 100% (incremented by 1%)
<b>FAX/TEL switching</b>	Provided
<b>Remote reception</b>	Provided
<b>Memory reception</b>	Send/Receive memory: More than 1000 pages (Total number of sent/received pages) *Based on the JBIG standard mode with ITU-T standard chart No. 1  Memory reception: Provided
<b>Others</b>	Dialing method - Address book (300 destinations) Group dialing (299 destinations) (incl. One-touch button (200 destinations)) - Regular dialing (by numeric keys) - Automatic redialing, manual redialing (specified from the calling record) - Broadcast transmission (301 destinations)  Output of reports - Communication management report (Automatically printed for every 40 calls) - Transmission result report / Reception result report  Reception method - Automatic reception - Remote reception by a telephone set (Initial setting ID: 25)
<b>Redial</b>	Automatic redialing: Provided
<b>Memory backup</b>	Number of memories which can be accumulated: 1236 sheets Memory backup time: 1 hour
<b>Time</b>	Within 60 sec per month (Zone A) Within 90 sec per month (Zone B)



---

## Chapter 2 Installation

---





---

# Contents

2.1 Unpacking and Checking the Components .....	2-1
2.1.1 Checking Contents .....	2-1
2.2 Installation Procedure .....	2-1
2.2.1 Turning OFF Power .....	2-1
2.2.2 Installation Procedure .....	2-1
2.2.3 After Installation .....	2-5
2.3 Attaching the Labels etc. ....	2-5
2.3.1 Putting Labels .....	2-5
2.4 Checking the Operation .....	2-5
2.4.1 Type Settings .....	2-5
2.4.2 Line Type Setting.....	2-5
2.4.3 FAX Communication Test.....	2-5



## 2.1 Unpacking and Checking the Components

### 2.1.1 Checking Contents

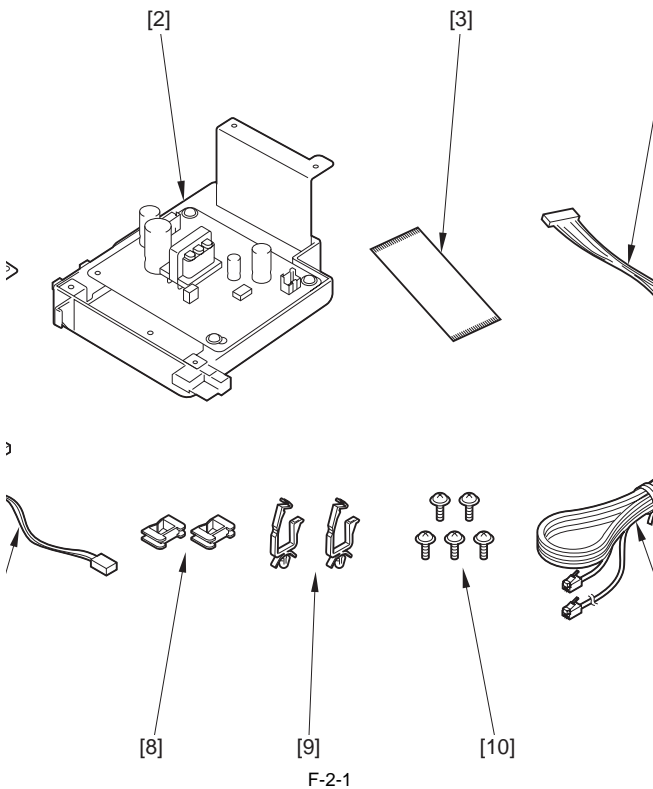

[1]	NCU board	1pc	[2]	OFF HOOK unit	1pc
[3]	Flat cable	1pc	[4]	NCU cable	1pc
[5]	NCU-modular cable	1pc	[6]	NCU-OFF-HOOK cable	1pc
[7]	OFF HOOK cable	1pc	[8]	Edge saddle	2pc
[9]	Wire saddle	2pc	[10]	Screw (TP; M3X6)	5pc
[11]*	Telephone cord	1pc	[12]	Approval label (For USA/AUS/EUR product only)	1pc

\* Connector shape differs depending on destinations

4 pieces are included in the EUR products.

3 pieces are included in the KOR products.

## 2.2 Installation Procedure

### 2.2.1 Turning OFF Power

- 1) Turn OFF the main power switch.
- 2) Remove the power plug (for outlet).

**NOTE:**

Since the host machine is not equipped with the hard disk, shut-down sequence is not required to turn OFF the main power switch.

### 2.2.2 Installation Procedure

- 1) Remove the reader hinge cover [1].  
- 4 claws [2]

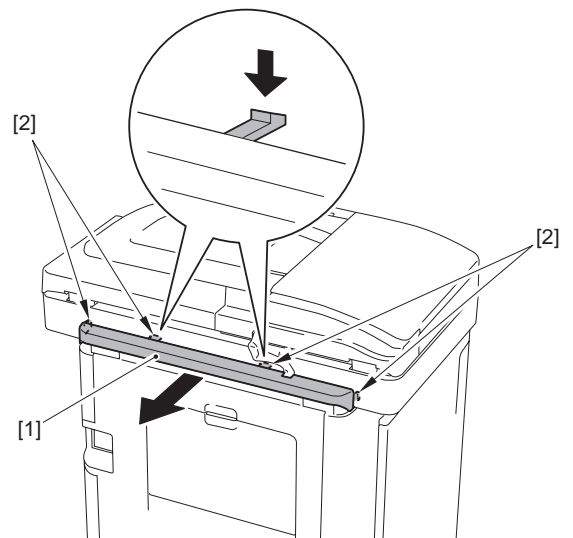

F-2-2

- 2) Remove the rear cover unit [1].  
- 2 screws [2]  
- 9 claws [3]

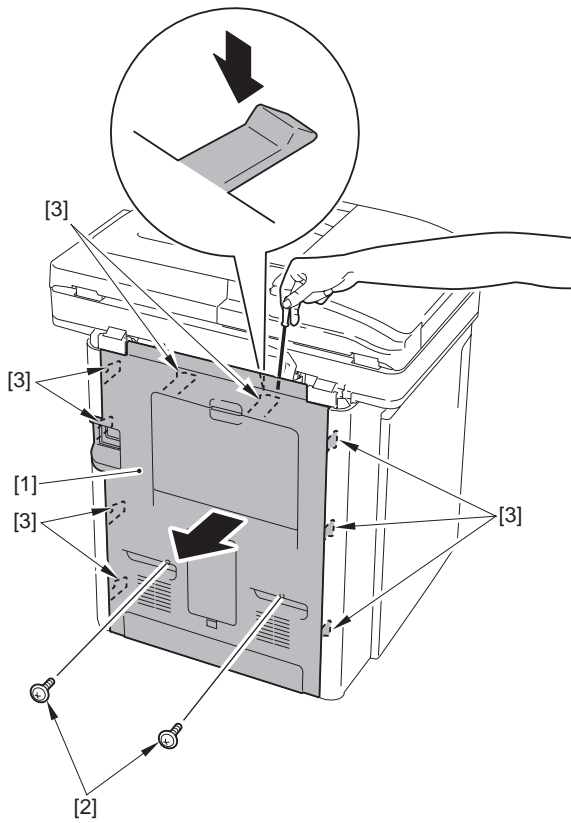

F-2-3

3) Remove the 3 screws[1].

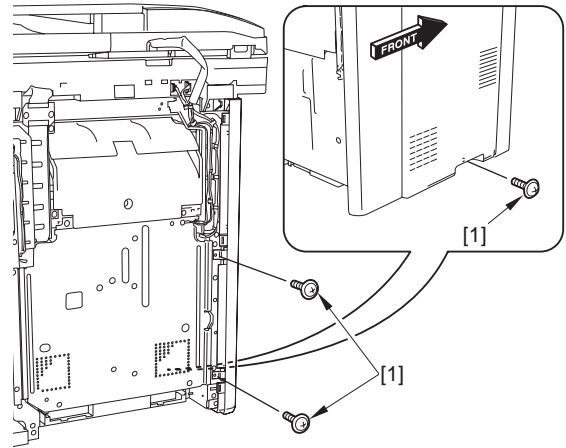
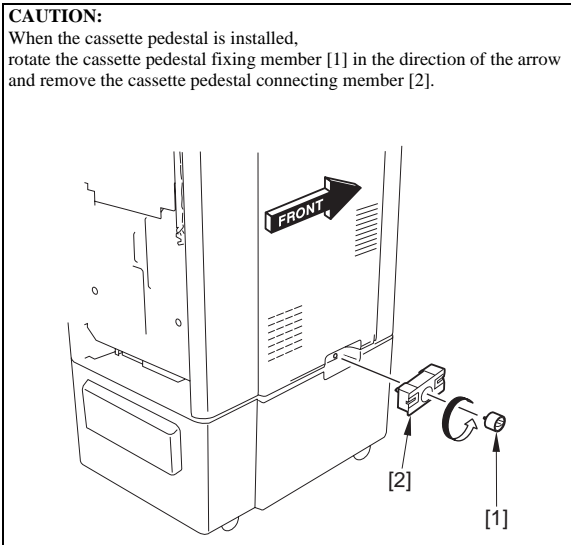

F-2-4

4) Move the left cover [2] to the position where the 2 screws [1] of the power unit cover can be removed.

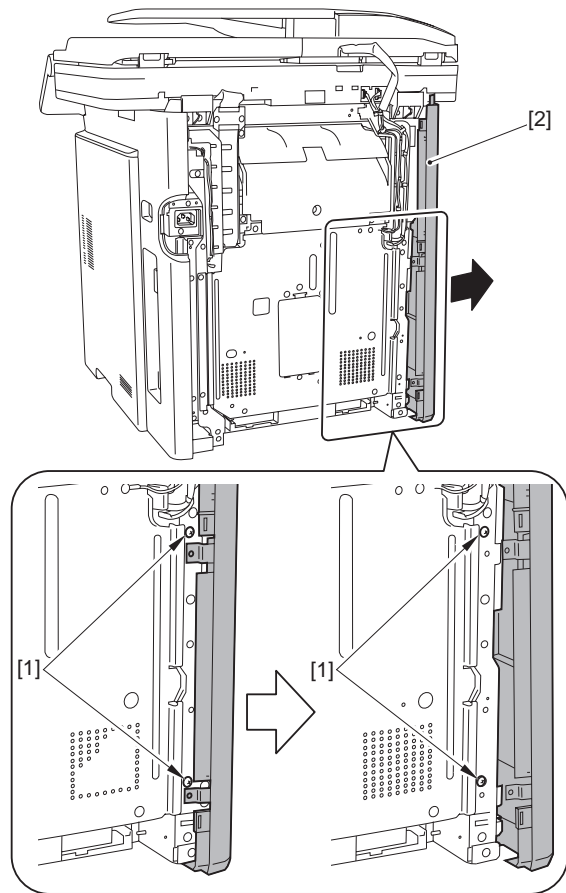

F-2-5

5) Remove the power unit cover [1].  
- 12 screws [2]  
- 1 terminal [3]

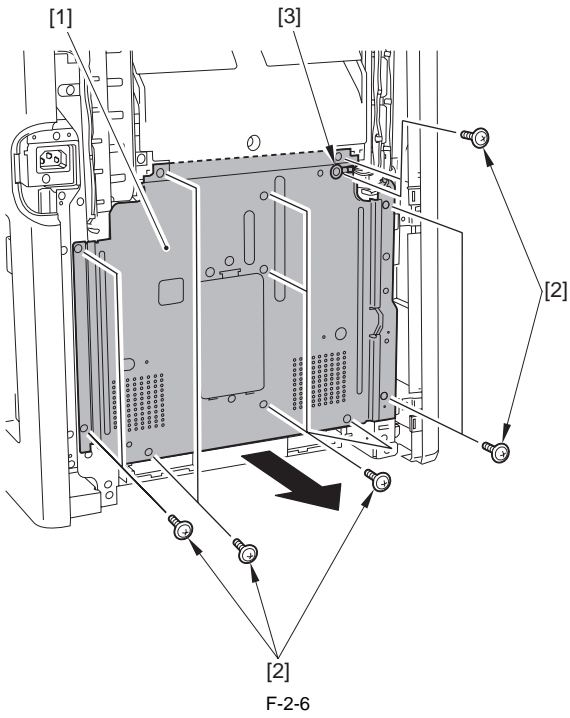

6) Connect the flat cable connector [1] and the NCU cable connector [2].

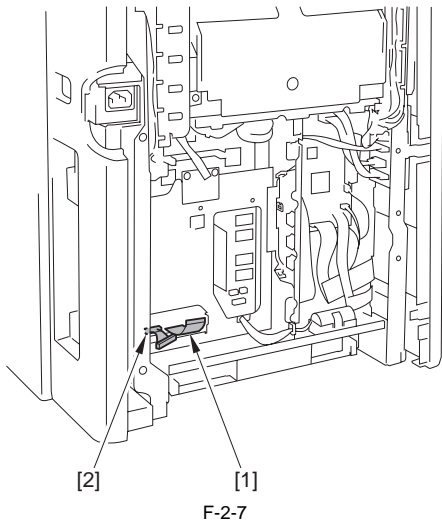

7) Install the NCU board [1].  
 - 2 hooks [2]  
 - 2 screws (TP; M3X6) [3]

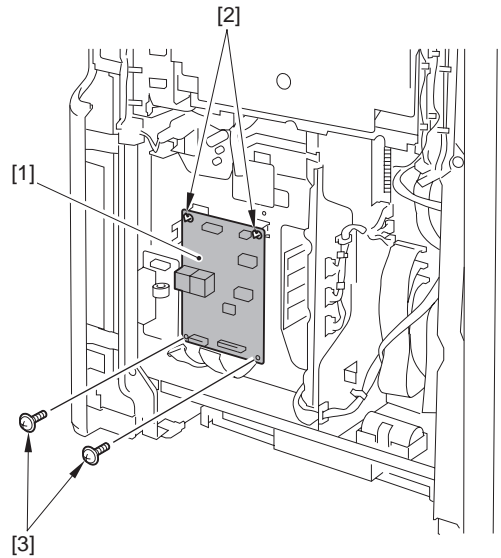

F-2-8  
 8) Connect the flat cable connector [1] and the NCU cable connector [2].

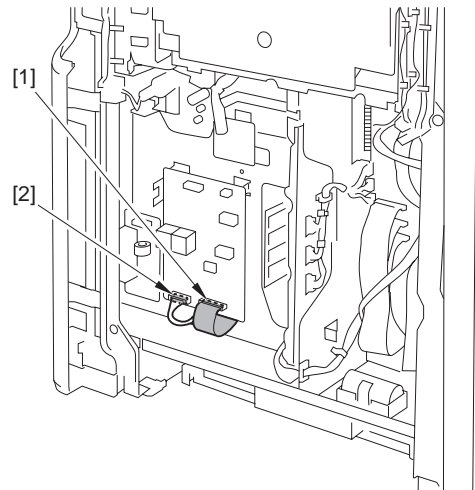

F-2-9  
 9) Install the edge saddle [1] and the 2 wire saddles [2].

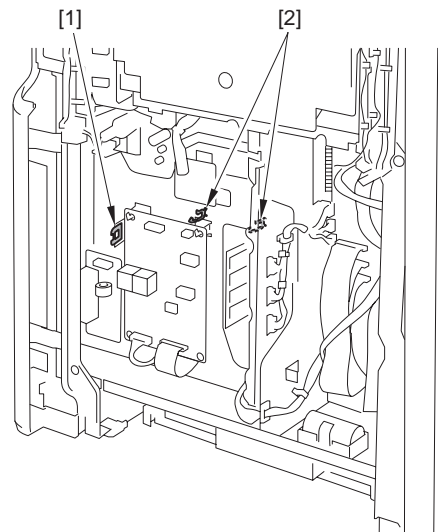

F-2-10  
 10) Connect the 2 NCU-modular cable connectors [1] and path them through the edge saddle [2].

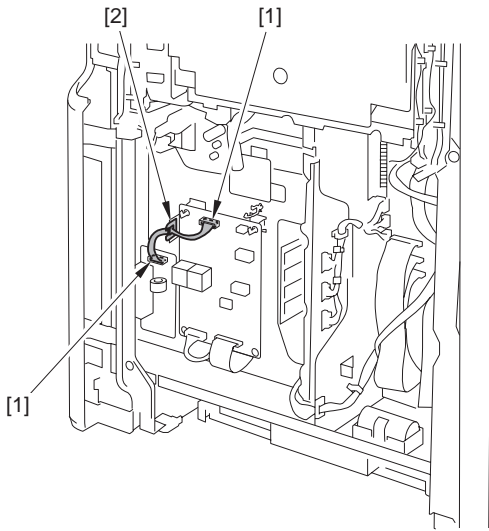

F-2-11

11) Install the edge saddle [1].

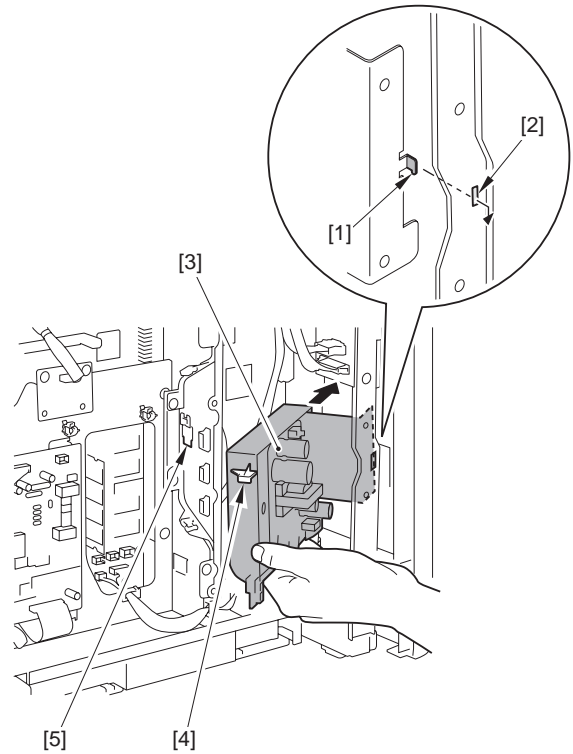

F-2-13

13) Fix the OFF HOOK unit [1].  
- 3 screws (TP; M3X6) [2]

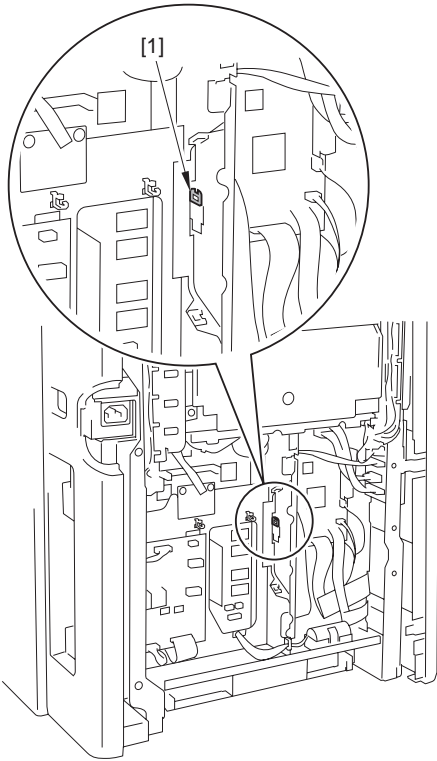

F-2-12

12) HOOK the claw [1] of the OFF HOOK unit onto the plate hole [2].  
Insert the OFF HOOK unit [3] in the direction of the arrow and engage the hook [4] with the cut-off [5].

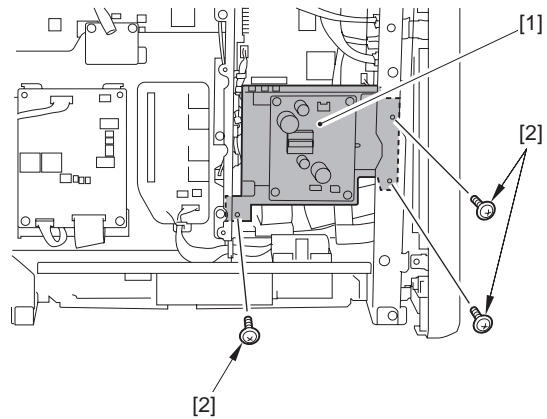

F-2-14

14) Put the NCU-OFF HOOK cable through the edge saddle [1] and connect the 2 NCU-OFF HOOK cable connectors [2].  
15) Secure the cable with 2 wire saddles [3] and put it through the harness guide [4].

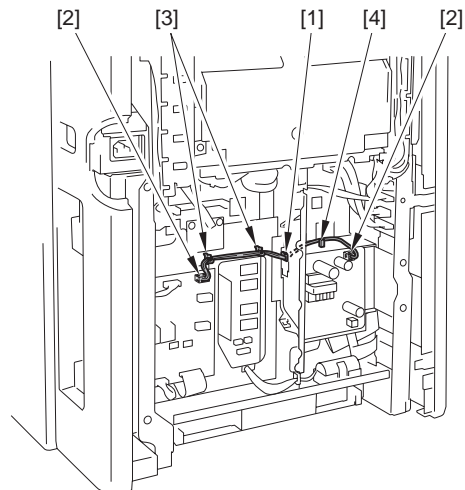

F-2-15

- 16) Connect the 2 OFF HOOK cable connectors [1] and secure them with the 2 edge saddles [2].

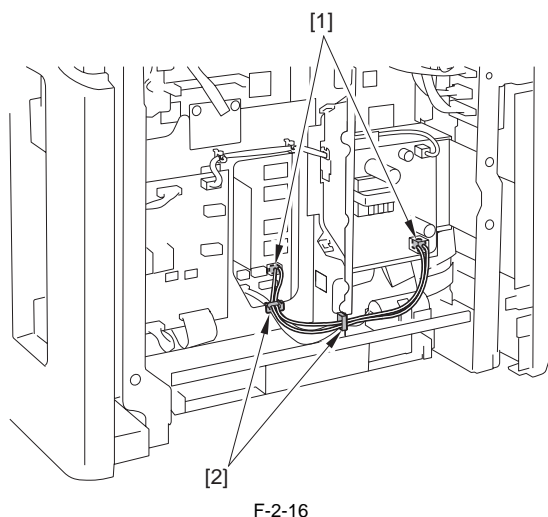

F-2-16

- 17) Install the removed parts.  
 - Power unit cover  
 - Left cover  
 - Rear cover unit  
 - Reader hinge cover
- 18) Remove the blanking sheet [1].

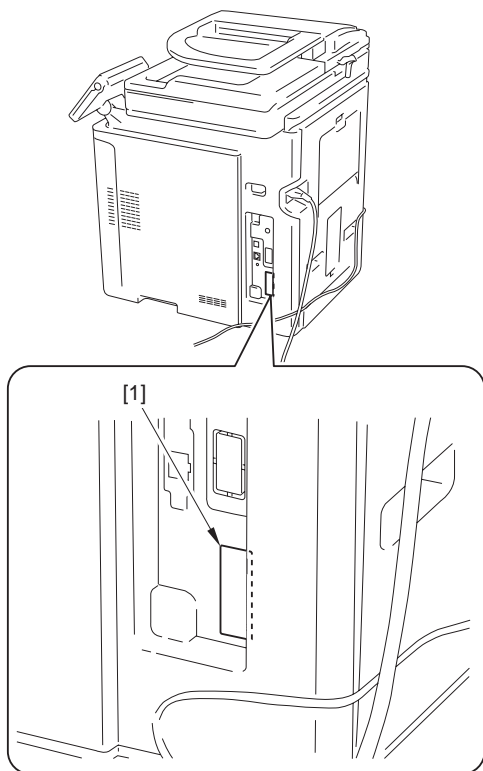

F-2-17

### 2.2.3 After Installation

- 1) Connect the telephone cord to the modular jack on the wall and connect the other side to the modular jack (for lines) of the host machine.
- 2) If using an extensional phone, connect the modular jack of extensional phone to the modular jack 'TEL' of this equipment.
- 3) Connect the power plug of the host machine into outlet and turn ON the main power switch.

## 2.3 Attaching the Labels etc.

### 2.3.1 Putting Labels

- 1) Put the approval label [1] on the indicated position as below.

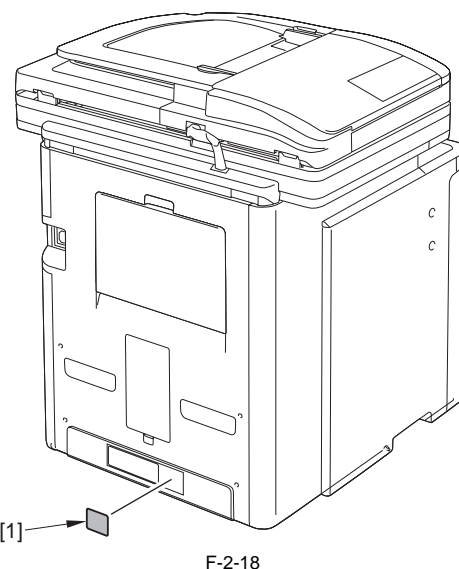

F-2-18

## 2.4 Checking the Operation

### 2.4.1 Type Settings

Specify the parameter corresponding to the communication standard of each country/area.

- 1) Specify the country/area settings of the FAX board in service mode.  
 Enter the service mode (Main Menu > 2 > 8 > Main Menu)  
 COPIER > FUNCTION > CLEAR > TYPE

**NOTE:**

When this operation is made, it takes approx 1 min for parameter setting.  
 Key operations are disabled during the time.

- 2) Exit the service mode.
- 3) If changing the setting in step 1), turn OFF/ON the main power switch.

### 2.4.2 Line Type Setting

Specify the setting of connected phone line.

- 1) Select the line types (manual) in additional function mode.  
 [Additional Func.] > [Communications Settings] > [FAX Settings] > [User Settings] > [Tel. Line Type Selection] > [Manual]
- 2) Specify the phone line to either dial Pulse (20PPS/10PPS) or Tone.

### 2.4.3 FAX Communication Test

Perform a communication test to check whether the FAX function works correctly.

- 1) Shift the control panel to the [Send/FAX] screen.
- 2) Send the test data from the host machine to other party that can accept the transmission test to check that the machine can send a data correctly.
- 3) Send the test data from other party to the host machine to check that the machine can receive a data correctly.





---

## Chapter 3 Functions

---



# Contents

3.1 Basic Construction .....	3-1
3.1.1 Overview .....	3-1



## 3.1 Basic Construction

### 3.1.1 Overview

The board is designed to enable a digital copier to serve as a high-performance multi-functional machine (image processing functions and communication functions over the telephone line).

It is capable of communicating at a maximum rate of 33.6 kbps, thanks to the presence of a V.34-compliant modem (ITU-T).

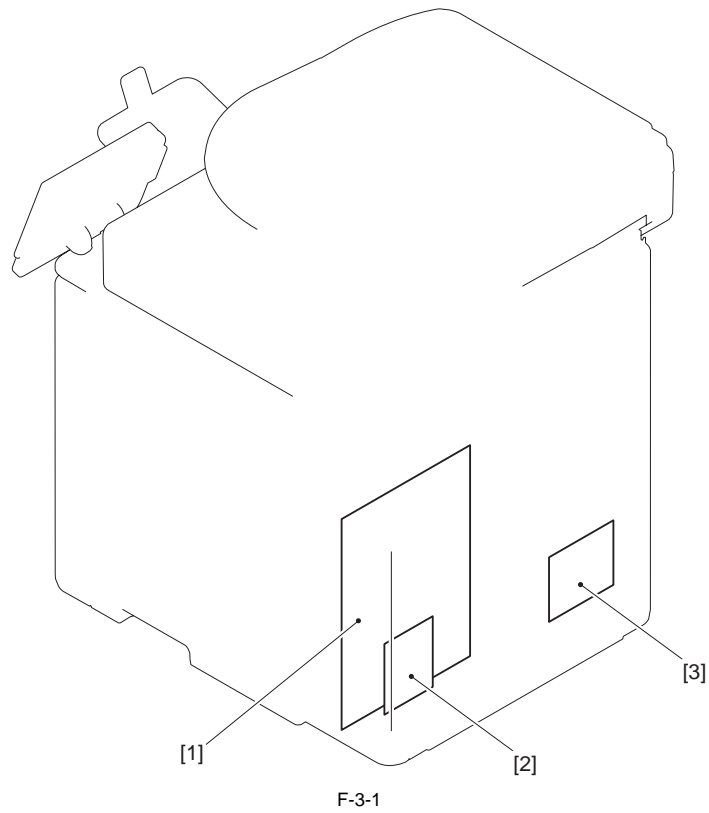

F-3-1

- [1] Main controller PCB
- [2] NCU PCB
- [3] Off hook PCB



---

## Chapter 4 Parts Replacement Procedure

---





# Contents

4.1 Removing from the Host Machine.....	4-1
4.1.1 FAX Unit .....	4-1
4.1.1.1 Pre-operation.....	4-1
4.1.1.2 Removing the NCU PCB .....	4-3
4.1.1.3 Removing the Off Hook PCB .....	4-3



## 4.1 Removing from the Host Machine

### 4.1.1 FAX Unit

#### 4.1.1.1 Pre-operation

- 1) Open the front cover [1].

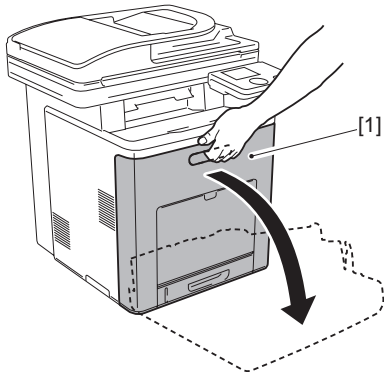

F-4-1

- 2) While pushing the ETB lock lever [1] (2 points at left and right), remove the ETB unit [2].



#### Points to Note At Handling

Be careful not to touch the surface of the ETB belt or damage it. Dirts or small cuts on the belt may cause image faults.

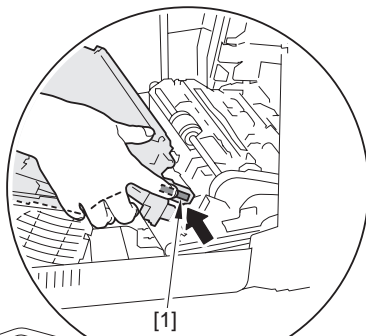

[1]

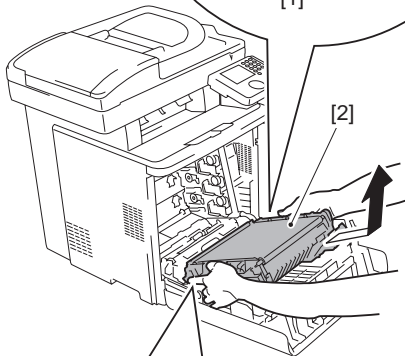

[2]

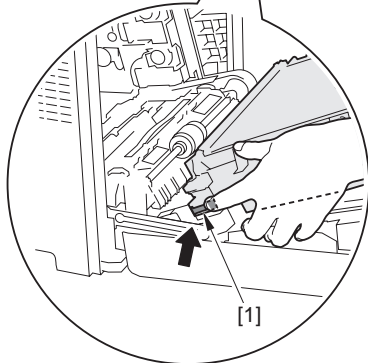

[1]

F-4-2



When closing the front cover with the ETB unit removed and then opening it, the drawer connector [1] faces upward. The drawer connector facing upward may cause the following symptoms; and therefore, be sure to put down the 2 drawer connectors [1] if necessary.

- When the toner cartridge is not removed  
The shutter of the toner cartridge is opened, resulting in deteriorated sensitivity of the photosensitive drum.
- When the toner cartridge is removed  
The coupling [2] and lock mechanism [3] of the toner cartridge works together and the toner cartridge cannot be installed.

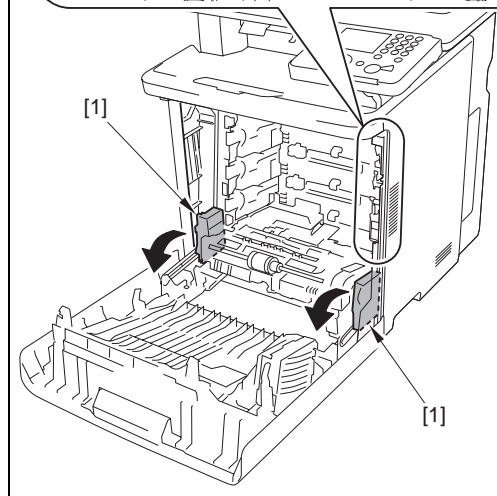
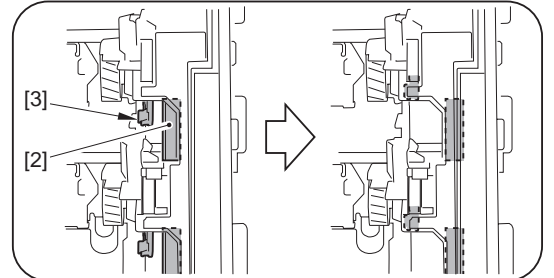

- 3) Remove the reader hinge cover [1].  
- 4 claws [2]

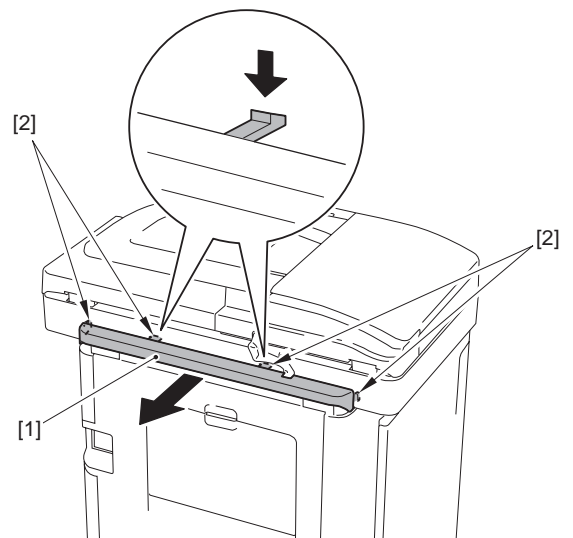

F-4-3

- 4) Remove the rear cover unit [1].  
- 2 screws [2]  
- 9 claws [3]

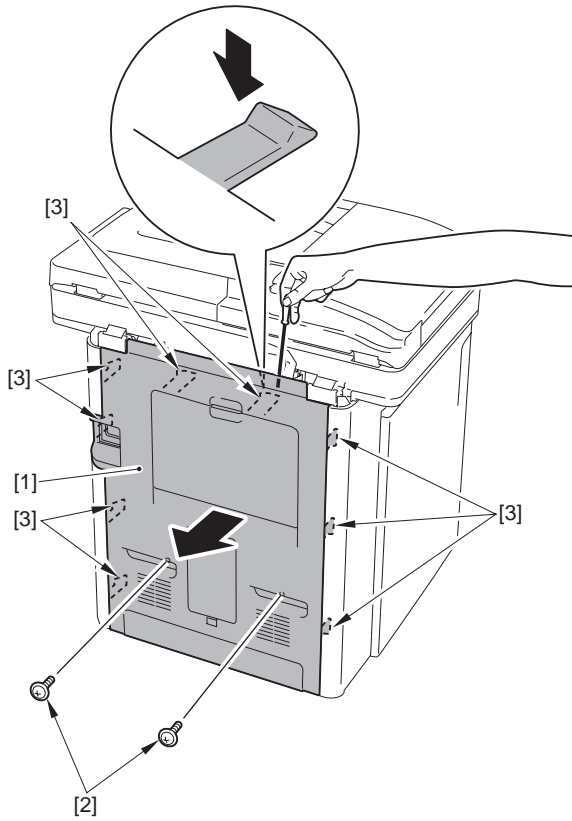

F-4-4

5) Open the ADF unit + reader unit [1].

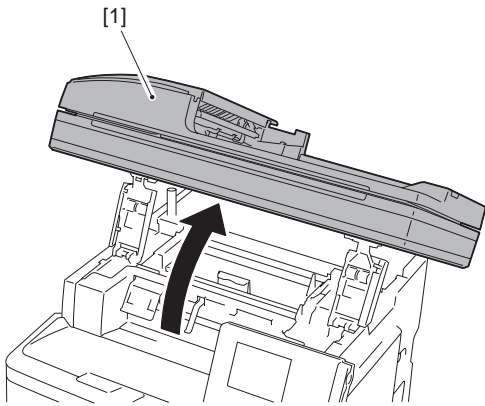

F-4-5

**⚠ Points to note at work**  
 Be sure not to close the ADF unit + reader unit hastily. If closing the ADF unit + reader unit hastily, the impact can cause damage.  
 Also be careful not to get your hands caught between the ADF unit + reader unit and the host machine.

6) Remove the 3 screws [1].

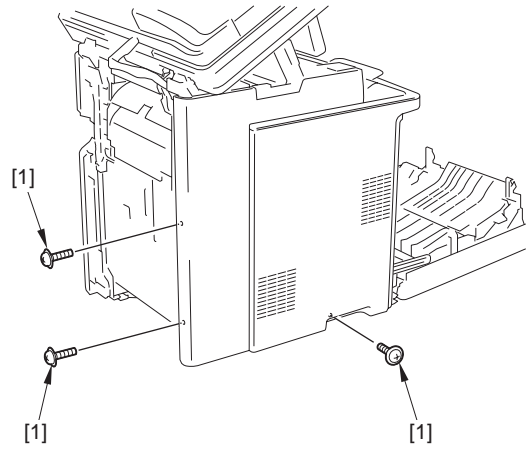

F-4-6

7) Remove the 2 hooks [2] of the left cover [1] in the direction of the arrow [A].  
 8) Remove the 6 claws [3] and the 2 hooks [4] and move the left cover [1] in the direction of the arrow [B].

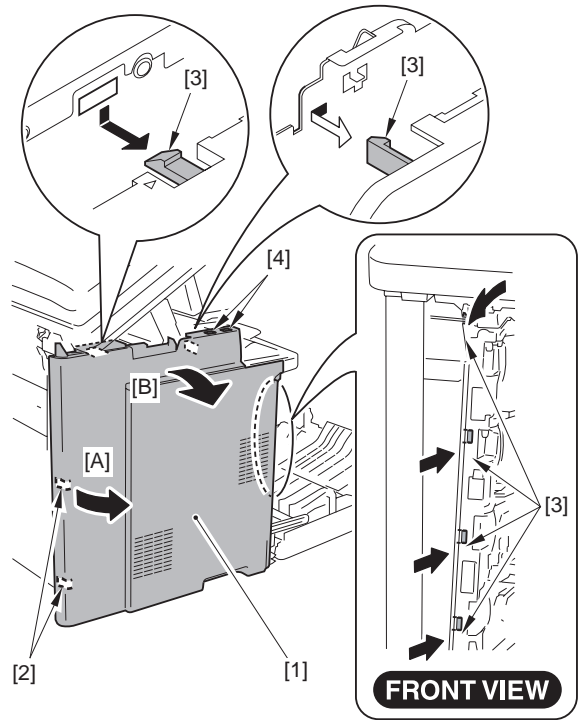

F-4-7

9) Move the left cover [1] in the direction of the arrow, and release the projection [2], the projection [3] and the claw [4] to remove.

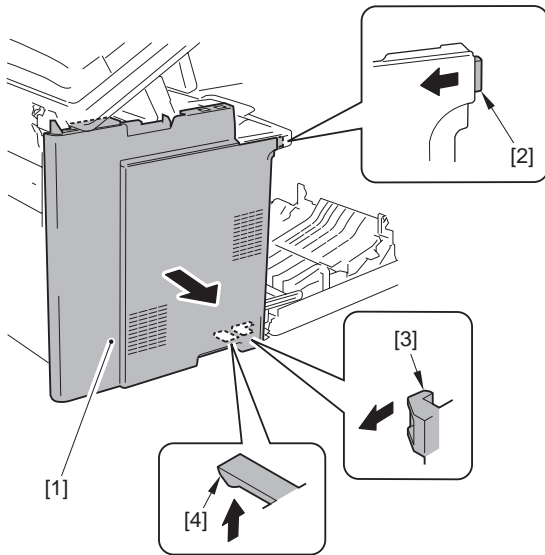

F-4-8

**⚠ Point to Note at Installation**

Be sure to install the left cover by fitting the boss [1] and the projection [2] of the left cover with the harness guide hole [3] and the groove [4] of the host machine.

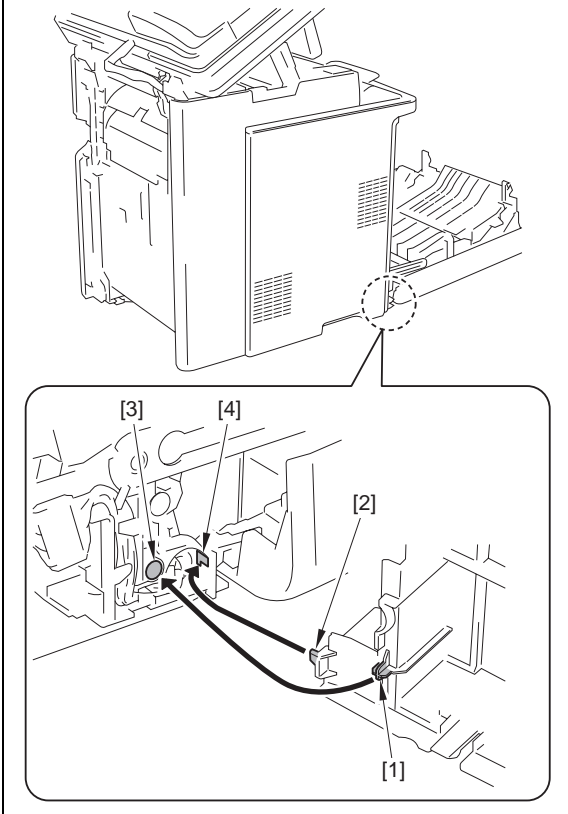

- 10) Remove the electrical components cover [1].  
 - 12 screws [2]  
 - 1 terminal [3]

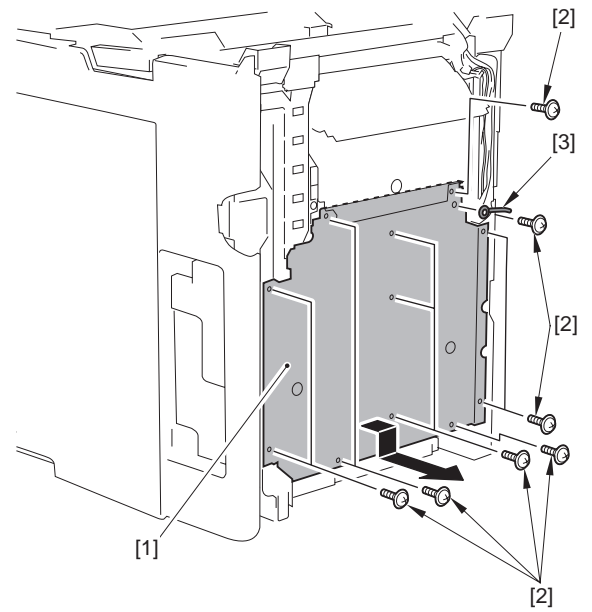

F-4-9

**4.1.1.2 Removing the NCU PCB**

- 1) Remove the NCU PCB.  
 - 1 flat cable [2]  
 - 3 connectors [3]  
 - 2 screws [4]

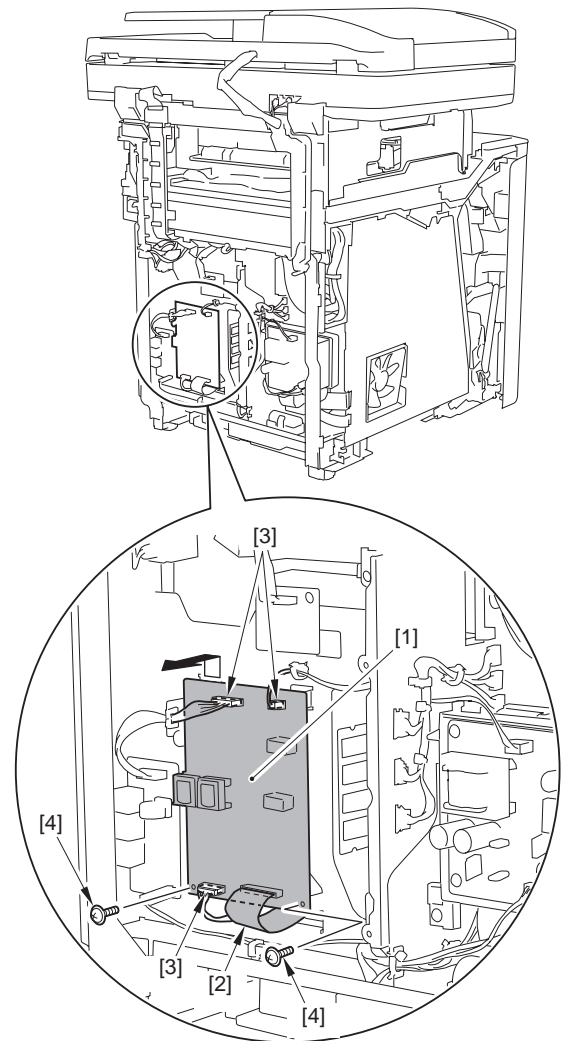

F-4-10

**4.1.1.3 Removing the Off Hook PCB**

- 1) Remove the the Off Hook PCB unit [1].

- 2 connectors [2]
- 3 screws [3]
- 1 hook [4]

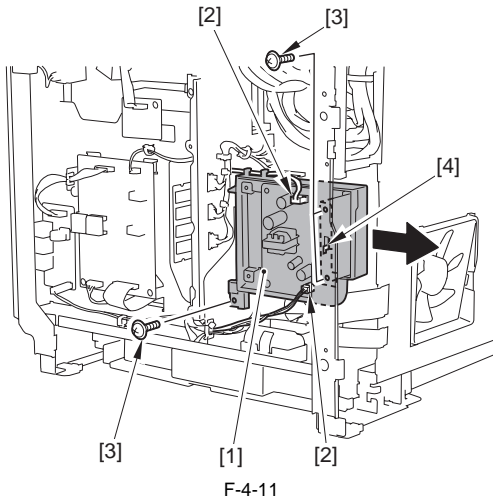

---

## Chapter 5 Service Mode

---





---

# Contents

5.1 Outline.....	5-1
5.1.1 Service Mode Configuration.....	5-1
5.1.2 Exiting Service Mode .....	5-3
5.1.3 Service Mode Backup.....	5-3
5.1.4 Service Mode Backup.....	5-4
5.2 Setting of Bit Switch (SSSW).....	5-6
5.2.1 Outline.....	5-6
5.2.1.1 SSSW List .....	5-6
5.3 Setting of Menu Switch (MENU) .....	5-7
5.3.1 MENU List.....	5-7
5.4 Setting of Numeric Parameter (NUMERIC Param.) .....	5-7
5.4.1 NUM List.....	5-7





The machine's service mode is categorized in to the following modes.

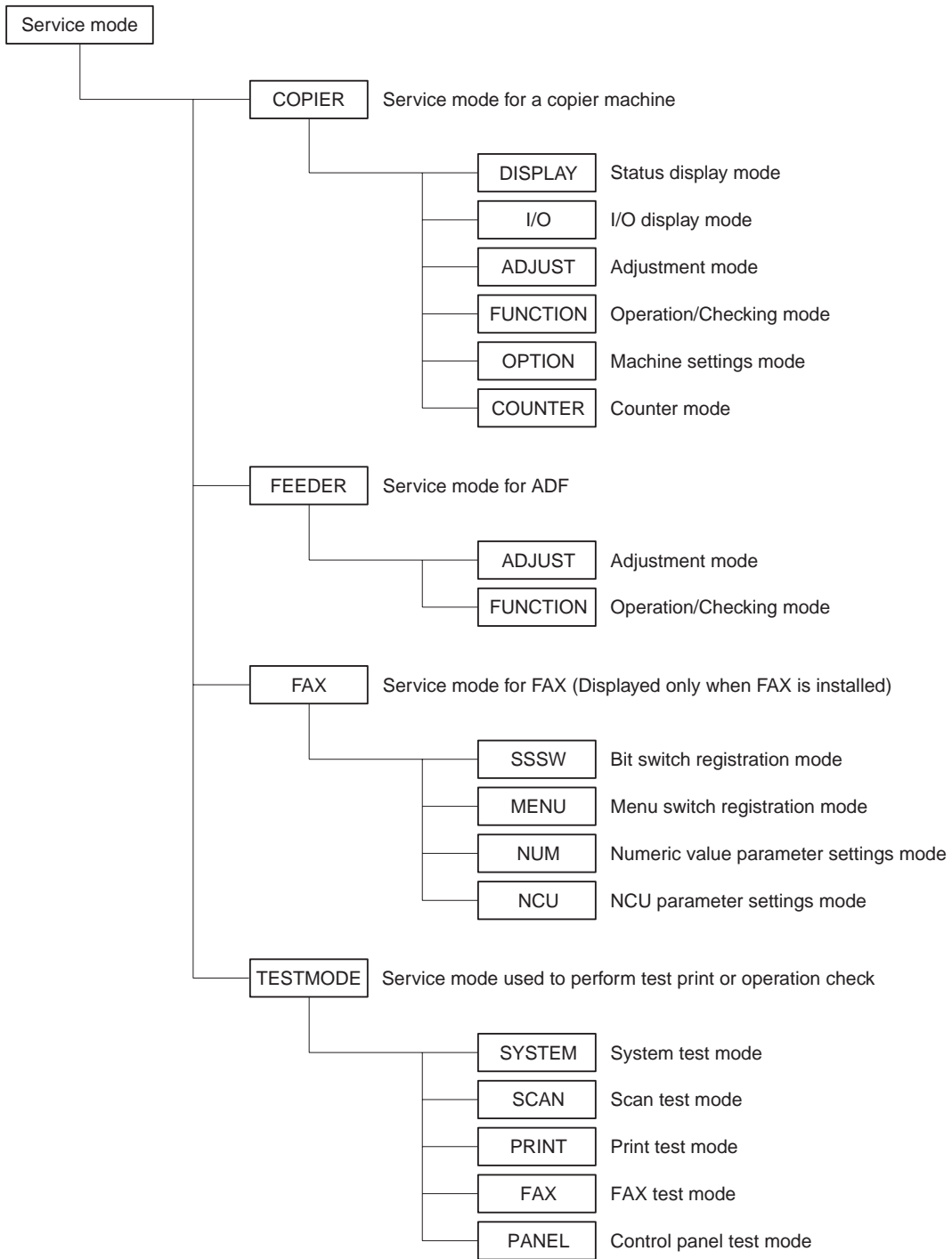

F-5-2

### 5.1.2 Exiting Service Mode

Every time the Return key is pressed in a screen other than the initial screen, the screen goes back to the previous one. When the Return key is pressed in the initial screen, the screen goes back to the main menu screen.



When using the service mode (ADJUST, FUNCTION, OPTION), be sure to turn the main power switch OFF/ON after exiting the service mode.

### 5.1.3 Service Mode Backup

Since there is no service label in the machine, printing in the service mode setting value is not available either. Hence, adjustment in the market is being performed. Please note that when the value service mode is modified, be sure to record the modified value.

**MEMO:**

When PCB is replaced or RAM clearing is performed, the adjusted ADJUST and OPTION value will return to default value.

### 5.1.4 Service Mode Backup

**Initial/Main/Intermediate screen**

- To select the item: ▲/▼ key or scroll wheel
- To display the items on the lower layer: OK key
- To display the items on the upper layer: Back key

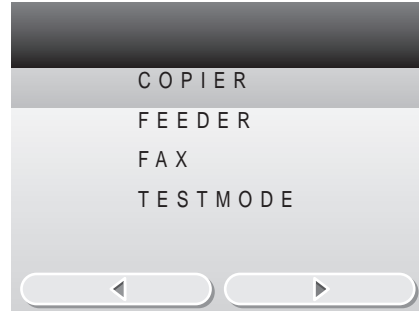

**Sub screen 1**

- To select the item: ▲/▼ key or scroll wheel
- To display the each setting screen: OK key
- To display the intermediate screen: Back key
- Setting value: [1]
- Setting range: [2]

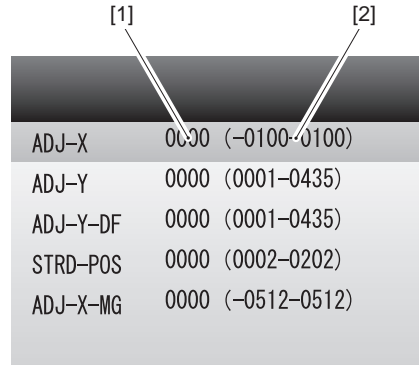

**ON/OFF selection screen**

- To select the setting: ▲/▼ key or scroll wheel
- To change the setting: OK key
- To not change the setting: Back key

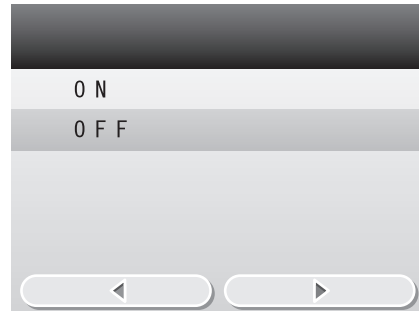

**Numeric value entry screen 1**

- To enter the setting value: Numeric keys
- To increase the setting value by 1: ► key or scroll wheel (clockwise)
- To decrease the setting value by 1: ◀ key or scroll wheel (counterclockwise)
- To enter the negative setting value: Right any key (if displayed), ◀ key or scroll wheel (counterclockwise) (continue to operate until the value smaller than 0 is displayed)
- To change the setting: OK key
- To not change the setting: Back key

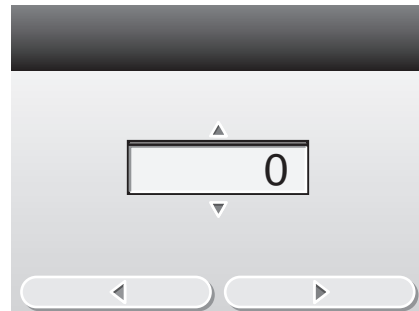

**Switch selection screen**

- To select the switch: ▲/▼ key or scroll wheel
- To display the entry screen of switch setting value: OK key
- To display the small screen: Back key

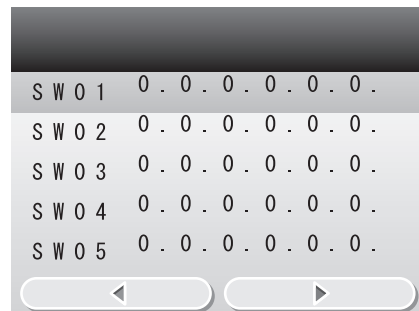

**Entry screen of switch setting value**

- To select the setting item: ◀▶ key
- To switch the setting value: Right any key (0 or 1 can be selected)
- To change the setting: OK key
- To not change the setting: Back key

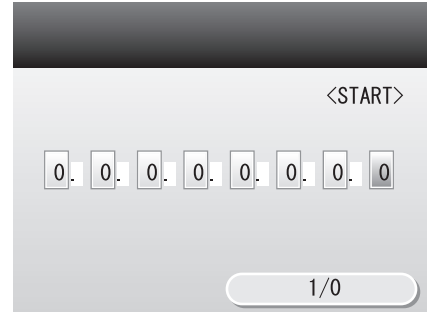

**Small screen 2**

- To select the item: ▲/▼ key or scroll wheel
- To display the each setting screen: OK key
- To display the previous screen: Back key
- Setting value: [1]

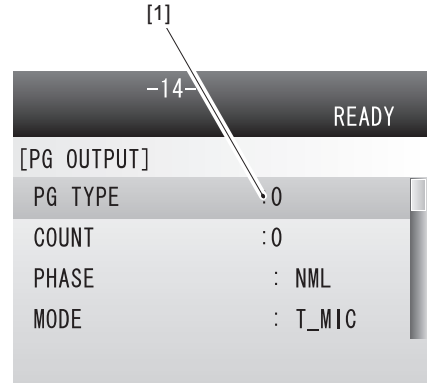

**Item selection screen**

- To select the setting: ▲/▼ key or scroll wheel
- To change the setting: OK key
- To not change the setting: Back key



**Numeric value entry screen 2**

- To enter the setting value: Numeric keys
- To change the setting: OK key
- To not change the setting: Back key



## 5.2 Setting of Bit Switch (SSSW)

### 5.2.1 Outline

#### 5.2.1.1 SSSW List

T-5-1

SSSW No.	Bit No.	Function
01		(Error, Copy function-related)
	0	Error code output for service engineer
02		(Network connecting condition setting-related)
	4	Forbid communication control that supports V34 CCRTN OFF IP network
	7	Connect as F-network 2-type terminal
03		(Echo-related)
	0	TCF EQM check
	1	Transmit echo protection tone to V.29
	7	Output 1080Hz before CED
04		(Communication trouble-related)
	1	Check frequency of CI signal
	2	V.21 end flag
	3	Forbid duplex waiting of T.30 node
	4	T.30 node F echo timer
	5	Check frequency of CI signal at PBX settings
	6	Do not deliver CNG at manual transmission
	7	Do not deliver CED at manual reception
05		(Standard function, DIS signal setting-related)
	1	mm/inch convert (text mode)
	2	mm/inch convert (text photo/photo mode)
	3	Forbid bit delivery after bit 33 of DIS
	4	Cut paper declaration
06		(Scanning condition settings)
	4	Scanning width 0: A4, 1: LTR
12		(Page timer settings-related) Time by 2-bit combination (0, 0): 8 min, (0, 1): 16 min, (1, 0): 32 min, (1, 1): 64min  When bit 7 is 0: - 1 page timeout time is specified with bit 1 and bit 0 regardless of any mode communication. When bit 7 is 1: - The timeout time for general transmission is specified with bit 1 and bit 0, for HT transmission with bit 3 and bit 2, for reception with bit 5 and bit 4
	0	1 page timeout time (transmission)
	1	
	2	1 page timeout time (HT transmission)
	3	
	4	1 page timeout time (reception)
	5	
	7	1 page timeout time
13		
	2	Convert mm/inch when sending received image
14		
	2	Whether executing inch to mm conversion in both main and sub scanning directions, or in sub scanning direction only
	4	Perform inch-type resolution declaration
15		
	2	Accept receiving ND line: Host machine line
	6	Detect continuous signal at F/T switching
18		
	0	Detect carrier disconnection between DCS and TCF
	1	Waiting time for carrier disconnection between DCS and TCF
	2	Forbid communication control for IP network
22		
	0	Forbid delivering NSX
	3	Forbid manual polling operation
25		(Report display function settings-related)
	0	Prioritize received phone number to dialed number
	2	When receiving blank CSI, regard the CSI as not-received
	3	Message language selection user SW



SSSW No.	Bit No.	Function
28		
	0	Forbid V8 procedure at calling side
	1	Forbid V8 procedure at receiving side
	2	Forbid V8 late start at calling side
	3	Forbid V8 late start at receiving side
	4	Forbid fallback start from V.34 receiving side
30		
	5	New dial tone detection method
32		
	5	0: NCU2004, 1: NCU2002
33		
	0	(Record) whether to count B4 size as large size or not
	2	(Scan) whether to count B4 size as large size or not
35		
	0	e-RDS function (0: OFF/1: ON)

## 5.3 Setting of Menu Switch (MENU)

### 5.3.1 MENU List

T-5-2

Registration mode of menu switch		
Number	Parameter	Description of the selection
05	ON/OFF of NL equalizer	0: OFF, 1: ON
06	Telephone line monitor	0: DIAL, 1: SERVICEMAN1, 2: SERVICEMAN2, 3: OFF
07	Delivery level (ATT)	0-15
08	Upper limit of V.34 modulating speed	0: 3429BAUD, 1: 3200BAUD, 2: 3000BAUD, 3: 2800BAUD, 4: 2743BAUD, 5: 2400BAUD
09	Upper limit of V.34 data speed	(Unit: kbps) 0: 33.6, 1: 31.2, 2: 28.8, 3: 26.4, 4: 24.0, 5: 21.6, 6: 19.2, 7: 16.8, 8: 14.4, 9: 12.0, 10: 9.6, 11: 7.2, 12: 4.8, 13: 2.4
10	Frequency of pseudo CI signal	0: 50 Hz, 1: 25 Hz, 2: 17 Hz

## 5.4 Setting of Numeric Parameter (NUMERIC Param.)

### 5.4.1 NUM List

T-5-3

Numeric parameter setting mode		
Number	Parameter	Available setting range
02	RTN delivery condition X	1 to 99%
03	RTN delivery condition n	2 to 99 times
04	RTN delivery condition m	1 to 99 lines
05	NCC pause time (before ID code)	1 to 60 s
06	NCC pause time (after ID code)	1 to 60 s
10	T.30 T0 timer	Generally 55s
11	T.30 T1 timer (for receiving)	0 to 9999 (France = 3500, Others = 3000)
12	Maximum number of receiving lines	0 to 65535 (lines) Unlimited for 0
13	T.30 EOL timer	500 to 3000 (Default: 55s)
15	Threshold for hooking and on-hook	0 to 999
16	Time to temporarily response at FAX/TEL switching	0 to 9
17	Pseudo RBT cadence ON time	0 to 999
18	Pseudo RBT cadence OFF time (short)	0 to 999
19	Pseudo RBT cadence OFF time (long)	0 to 999
20	Pseudo ring tone cadence ON time	0 to 999
21	Pseudo CI cadence OFF time (short)	0 to 999
22	Pseudo CI cadence OFF time (long)	0 to 999
23	CNG detection level at FAX/TEL switching	0 to 7
24	Pseudo RBT delivery level at FAX/TEL switching	10 to 20 (100V), 0 to 20 (120/230V)
25	CNG monitoring time when answer phone is used	0 to 999
26	Level to detect no-sound when answer phone is used	0 to 7
27	Preamble detection time of V21 low-speed flag	20 (* 10ms)
51	Threshold value of hook detection	10 to

Numeric parameter setting mode		
Number	Parameter	Available setting range
53	Set the number of DTMF ringing times at FAX remote reception	10 to (Default: 25)
54	Set the transmission time of BusyTone when the handset is used	
55	Cycle to obtain data of environment log	0 to 480 min (Default: 60min) (No data is obtained with 0)
56	Select counter type to be displayed at counter 1	101
57	Select counter type to be displayed at counter 2	0 to 999
58	Select counter type to be displayed at counter 3	0 to 999
59	Select counter type to be displayed at counter 4	0 to 999
60	Select counter type to be displayed at counter 5	0 to 999
61	Select counter type to be displayed at counter 6	0 to 999
74	Port number of e-RDS RGW	
75	Transmission interval of e-RDS for 3rd party	

Oct 29 2010

**Canon**